

clarks

2019 MİMARİ KATALOG

2019 ARCHITECTURAL CATALOGUE



YALITIMLI VE YALITIMSIZ KAPI-PENCERE SİSTEMLERİ

INSULATED AND NON-INSULATED DOOR & WINDOW SYSTEMS





-
- Ender Alüminyum, kataloglarda gerekli gördüğü takdirde değişiklik yapma hakkını saklı tutar.
 - Bu katalogta yer alan tüm ürünler Türk Patent Enstitüsü tarafından tescil edilmiştir.
 - Katalogta yer alan profil ağırlıkları teorik olarak hesaplanmış olup, teslim anındaki tartımız geçerlidir.
- Baskı : Mayıs.2019
-





İYİ TASARIM, DOĞRU MALZEME İLE MÜKEMMELLEŞİR...

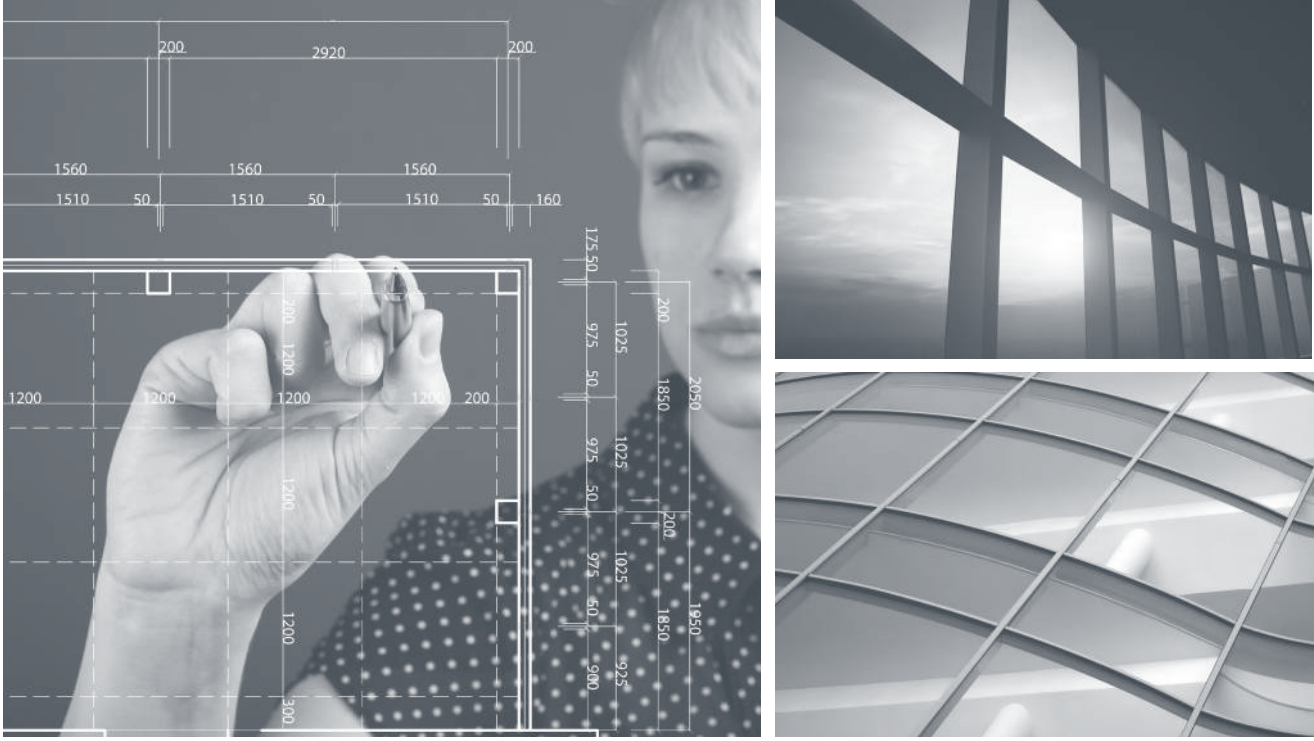

Ender Alüminyum Yapı Elemanları Sanayi ve Ticaret A.Ş. 2005 yılında Gaziantep 4. Organize Sanayi de 56.000 m2 lik fabrika alanındaki modern tesislerinde üretime başlamıştır.

Kuruluşundan bu yana sürekli gelişimi dikkate alan Ender Alüminyum, Orta Asya, Avrupa, Balkan ülkeleri, Afrika ve Arap ülkelerine ihracat yapmaktadır. Marka bilinirliğinin artması için ve ülkemizin alüminyum sektöründe önemli bir marka olması konusunda sürekli yatırımlarına devam etmektedir.

Müşterilerimizin tüm ihtiyaçlarını karşılamak için konusunda uzman ve tecrübeli pazarlama ekibimiz görev yapmaktadır. Ender ailesi müşterilerinin; ürün kalitesi ve performans beklentilerini, yenilikçi anlayışıyla sürekli geliştirerek, müşteri memnuniyetlerini arttırmayı ilke edinmiştir.

Ender Alüminyum modern tesislerinde ekstrüzyon, elektrostatik toz boya, eloksal ve nihai uygulamaları bünyesinde bulundurmaktadır. 4 adet pres ile 12.000 ton ekstrüzyon imalatı, 9.000 ton Elokسال ve yıllık 3.000 ton statik toz boya ünitesi kapasitesine sahiptir.

Başlıca ürünleri;

- Muhtelif sanayi profilleri,
 - Standart profiller,
 - Yalıtımlı - yalıtımsız doğrama,
 - Sürme,
 - Işıklık,
 - Çelik takviyeli cephe,
- ayrıca müşterilerinin taleplerine göre siparişe yönelik hizmet verebilmektedir.



GOOD DESIGN PERFECTED WITH THE RIGHT MATERIAL...

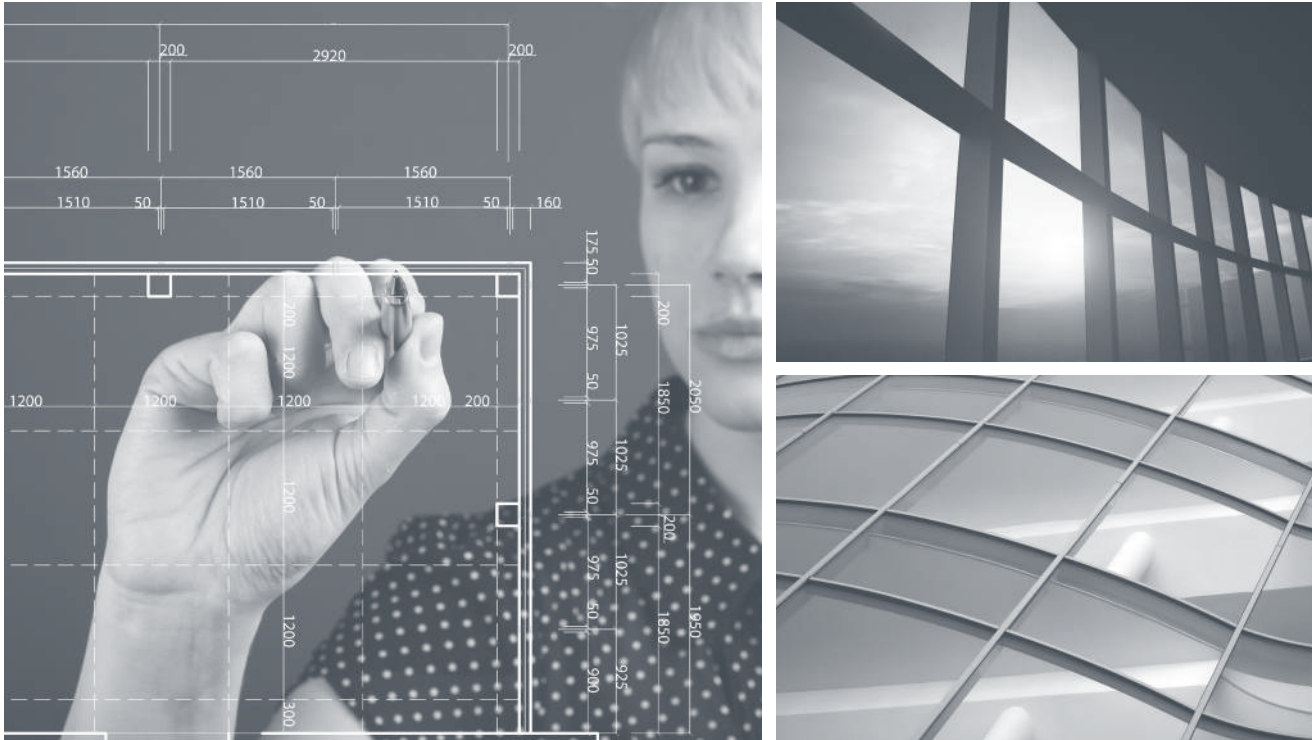

In 2005, Ender Aluminum structural elements Co. began production in its modern facilities on 56000 m² at Gaziantep's 4th organized industrial zone.

Since its establishment, Ender Aluminum focuses on continuous development and exports to Middle Asia, Europe, Balkans, Africa and Arabic countries. Ender Aluminum makes continuous investments for increasing its brand awareness and making Turkey an important brand name in aluminum sector.

Its expert and experienced marketing team is working to fulfill all customers' need. The main principle of Ender family is improving customer satisfactions about product quality and performance expectations with its innovative approach and continuous development.

The modern facility of Ender Aluminum contains extrusions, electrostatic powder paint, anodized paint and final applications. The production capacities are: 12000 tons of extrusion with 4 presses, 9000 tons of anodized painted and 3000 tons of electrostatic powder painted product.

Main products are:

- Miscellaneous industrial profiles
- Standard profiles
- With or without heat insulated joinery
- Sliding
- Skylight
- Steel reinforced facade
- Also could serve according to the customer needs

clarks

YENİ NESİL SİSTEMLER

A NEW GENERATION
OF SYSTEMS

**ALÜMİNYUM KAPI,
PENCERE VE CEPHE
SİSTEMLERİ**

ALUMINIUM DOOR,
WINDOW AND FACADE
SYSTEMS





clarks

İÇİNDEKİLER - INDEX

E 55

09 - 82

Yalıtımlı Pencere ve Kapı Sistemleri
Insulated Window & Door Systems

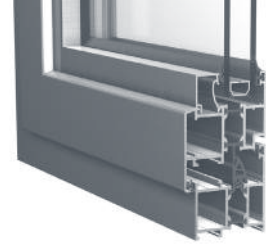

E 64

83 - 154

Yalıtımlı Pencere ve Kapı Sistemleri
Insulated Window & Door Systems

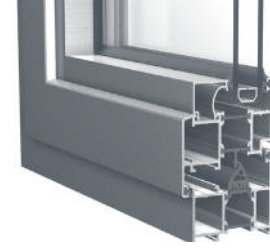

E 74

155 - 230

Yalıtımlı Pencere ve Kapı Sistemleri
Insulated Window & Door Systems



EDR 55

231 - 274

Yalıtımsız Pencere ve Kapı Sistemleri
Non - Insulated Window & Door Systems

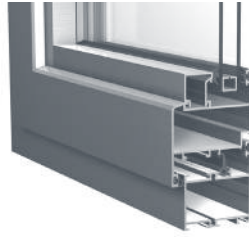

SERTİFİKALAR CERTIFICATES

275 - 304





clarks

E 55



E 55 - 1.5 - 1.8 - 2.00 T
YALITIMLI PENCERE VE KAPI SİSTEMLERİ



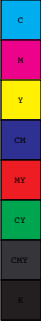



E 55 - 1.5 - 1.8 - 2.00 T
INSULATED WINDOWS & DOORS SYSTEMS



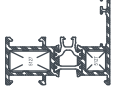
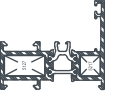

E 55

PROFİL İNDEKS / PROFILE INDEX

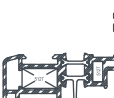
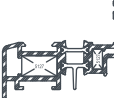
COD Code	PROFİL KESİTİ Profile View	PROFİL AÇIKLAMASI Profile Description	AGIRLIK (kg/m) Weight	Jxx cm ⁴	Jyy cm ⁴	Wxx cm ³	Wyy cm ³
5317		KASA PROFILI FRAME PROFILE	1,111	14,13	3,50	4,20	1,38
5300		KASA PROFILI FRAME PROFILE	1,172	15,20	3,62	4,53	1,42
5318		KASA PROFILI FRAME PROFILE	1,427	18,68	9,50	4,95	3,08
5301		KASA PROFILI FRAME PROFILE	1,512	20,31	9,95	5,44	3,24
5725		KASA PROFILI FRAME PROFILE	1,571	21,41	10,30	5,78	3,73
5434		KASA PROFILI FRAME PROFILE	1,700	32,76	13,54	7,39	3,85
5433		KASA PROFILI FRAME PROFILE	2,079	47,10	29,10	9,18	6,10
5319		KASA PROFILI FRAME PROFILE	1,807	30,76	19,90	5,65	5,04
5302		KASA PROFILI FRAME PROFILE	1,924	32,90	21,73	6,05	5,46
5320		KASA PROFILI SASH PROFILE	1,352	24,59	3,60	5,76	1,87
5303		KASA PROFILI SASH PROFILE	1,446	26,75	3,82	6,24	1,92

clarks

E 55

PROFİL İNDEKS / PROFILE INDEX

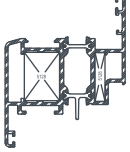
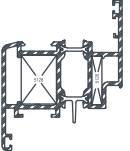
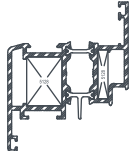
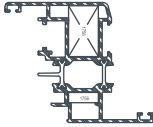
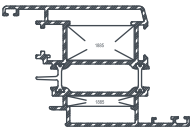
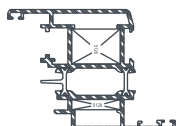
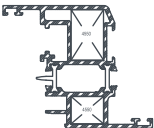
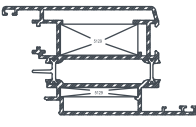
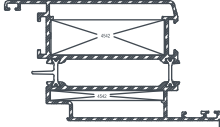
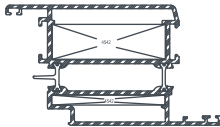
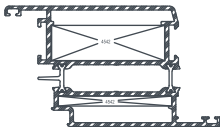
COD Code	PROFİL KESİTİ Profile View	PROFİL AÇIKLAMASI Profile Description	AGIRLIK (kg/m) Weight	Jxx cm ⁴	Jyy cm ⁴	Wxx cm ³	Wyy cm ³
5321		KASA PROFİLİ SASH PROFILE	1,700	32,15	10,29	6,77	3,84
5304		KANAT PROFİLİ SASH PROFILE	1,784	35,33	11,38	7,49	3,93
5711		KANAT PROFİLİ SASH PROFILE	1,828	37,46	10,88	7,83	3,83
5340		PVC KANALLI PENCERE KANADI PVC CHANNEL SASH PROFILE	1,595	30,67	8,62	6,51	3,12
5577		PVC KANALLI PENCERE KANADI PVC CHANNEL SASH PROFILE	2,064	49,25	21,41	8,58	5,41
5333		PVC KANALLI PENCERE KANADI PVC CHANNEL SASH PROFILE	2,005	42,51	15,98	8,26	4,74
5714		PVC KANALLI PENCERE KANADI PVC CHANNEL SASH PROFILE	1,859	38,88	11,34	8,26	4,06
5334		PVC KANALLI PENCERE KANADI PVC CHANNEL SASH PROFILE	2,573	74,37	35,08	11,47	8,19
5567		İÇE AÇILIR KAPI KANAT PRF. INNER OPENING DOOR SASH PROFILE	2,333	70,94	30,80	10,92	7,11
5564		İÇE AÇILIR KAPI KANAT PRF. INNER OPENING DOOR SASH PROFILE	2,498	75,11	34,97	11,45	8,03
5712		İÇE AÇILIR KAPI KANAT PRF. INNER OPENING DOOR SASH PROFILE	2,577	78,82	35,68	8,03	11,45



E 55

PROFİL İNDEKS / PROFILE INDEX

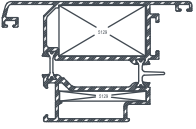
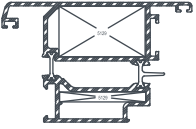
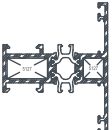
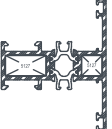
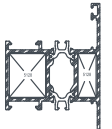
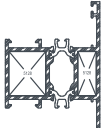
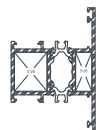
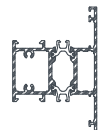
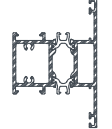
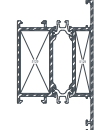
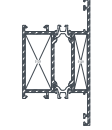
COD Code	PROFİL KESİTİ Profile View	PROFİL AÇIKLAMASI Profile Description	AGIRLIK (kg/m) Weight	Jxx cm4	Jyy cm4	Wxx cm3	Wyy cm3
5323		DISA AÇILIR KAPI KANAT PRF. OUTWARD OPENING DOOR SASH PROFILE	2,126	44,40	33,17	8,68	9,50
5306		DISA AÇILIR KAPI KANAT PRF. OUTWARD OPENING DOOR SASH PROFILE	2,308	48,32	37,50	9,59	10,44
5324		ORTA KAYIT PROFİLİ MULLION PROFILE	1,275	15,62	7,63	4,68	2,21
5307		ORTA KAYIT PROFİLİ MULLION PROFILE	1,344	16,78	7,96	5,03	2,30
5325		ORTA KAYIT PROFİLİ MULLION PROFILE	1,588	19,43	16,63	5,92	3,93
5308		ORTA KAYIT PROFİLİ MULLION PROFILE	1,684	21,22	17,37	6,48	4,13
5713		ORTA KAYIT PROFİLİ MULLION PROFILE	1,723	22,44	17,95	6,85	4,27
5327		VİDALI ORTA KAYIT PROFİLİ SCREW MULLION PROFILE	1,667	20,77	16,89	6,56	4,02
5310		VİDALI ORTA KAYIT PROFİLİ SCREW MULLION PROFILE	1,757	22,50	17,71	7,10	7,21
5326		ORTA KAYIT PROFİLİ MULLION PROFILE	1,970	37,77	24,42	7,26	7,55
5309		ORTA KAYIT PROFİLİ MULLION PROFILE	2,096	39,90	27,04	7,67	8,39



E 55



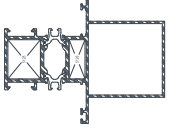
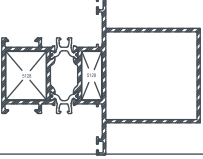
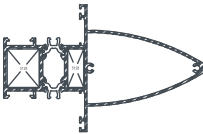
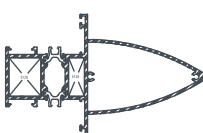
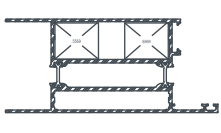
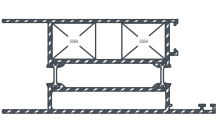
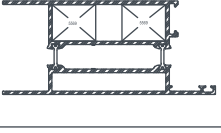
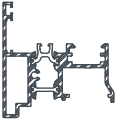
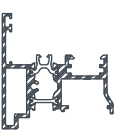
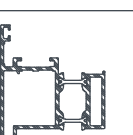
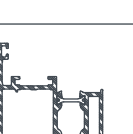





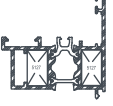
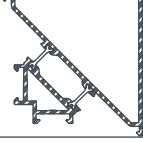

PROFİL İNDEKS / PROFILE INDEX

COD Code	PROFİL KESİTİ Profile View	PROFİL AÇIKLAMASI Profile Description	AGIRLIK (kg/m) Weight	Jxx cm4	Jyy cm4	Wxx cm3	Wyy cm3
5328		TAKV.ORTA KAYIT PROFİLİ SUPPORTED MULLION PROFILE	2,188	72,24	26,66	12,92	6,34
5311		TAKV.ORTA KAYIT PROFİLİ SUPPORTED MULLION PROFILE	2,398	82,25	29,33	15,05	6,98
5329		TAKV.ORTA KAYIT PROFİLİ SUPPORTED MULLION PROFILE	2,381	115,43	24,50	14,58	5,83
5312		TAKV.ORTA KAYIT PROFİLİ SUPPORTED MULLION PROFILE	2.600	127,17	26,77	16,27	6,37
5330		ETEK PROFİLİ KICK PROFILE	2,314	77,44	30,91	11,81	8,66
5313		ETEK PROFİLİ KICK PROFILE	2,505	85,03	35,10	12,83	9,81
5710		ETEK PROFİLİ KICK PROFILE	2,640	90,26	37,90	13,53	10,60
5331		ÇİFT KANAT ADAPTÖR PROF. DOUBLE SASH ADAPTER PROFILE	1,326	15,38	7,55	4,10	2,28
5314		ÇİFT KANAT ADAPTÖR PROF. DOUBLE SASH ADAPTER PROFILE	1,403	16,20	8,13	4,22	2,40
5332		PIVOT ADAPTÖR PROFİLİ PIVOTING ADAPTER PROFILE	1,352	18,31	8,85	4,92	2,68
5315		PIVOT ADAPTÖR PROFİLİ PIVOTING ADAPTER PROFILE	1,461	20,00	9,88	5,54	3,10

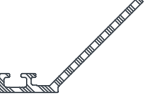

E 55







PROFİL İNDEKS / PROFILE INDEX

COD Code	PROFİL KESİTİ Profile View	PROFİL AÇIKLAMASI Profile Description	AGIRLIK (kg/m) Weight	Jxx cm4	Jyy cm4	Wxx cm3	Wyy cm3
5335		DISA AÇILIR KAPI ADAPTÖRÜ OUTWARD OPENING DOOR ADAPTER	1,142	12,39	5,27	4,01	1,94
5316		KÖSE DÖNÜS PROFILI CORNER PROFILE	1,987	40,77	34,30	7,78	6,83
5117		TIJ PROFILI SASH PROFILE	0,105	----	----	----	----
5336		KÖSE DÖNÜS PROFILI CORNER PROFILE	1,100	8,33	7,71	3,34	3,08
5337		ADAPTÖR PROFILI ADAPTER PROFILE	0,151	----	----	----	----
5338		ADAPTÖR PROFILI ADAPTER PROFILE	0,285	1,63	0,06	0,65	0,08
5339		ADAPTÖR PROFILI ADAPTER PROFILE	0,374	5,31	0,40	1,59	0,29
5572		TIJ PROFILI SASH PROFILE	0,100	----	----	----	----
5118		CAM ÇİTASI PROFILI GLAZING BEAD	0,249	----	----	----	----
5119		CAM ÇİTASI PROFILI GLAZING BEAD	0,251	----	----	----	----
5120		CAM ÇİTASI PROFILI GLAZING BEAD	0,255	----	----	----	----



E 55









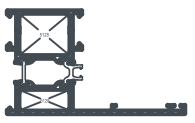

PROFİL İNDEKS / PROFILE INDEX

COD Code	PROFİL KESİTİ Profile View	PROFİL AÇIKLAMASI Profile Description	AGIRLIK (kg/m) Weight	Jxx cm4	Jyy cm4	Wxx cm3	Wyy cm3
5121		CAM ÇİTASI PROFİLİ GLAZING BEAD	0,260	----	----	----	----
5122		CAM ÇİTASI PROFİLİ GLAZING BEAD	0,267	----	----	----	----
5123		CAM ÇİTASI PROFİLİ GLAZING BEAD	0,274	----	----	----	----
5124		CAM ÇİTASI PROFİLİ GLAZING BEAD	0,281	----	----	----	----
5125		CAM ÇİTASI PROFİLİ GLAZING BEAD	0,292	----	----	----	----
5526		CAM ÇİTASI PROFİLİ GLAZING BEAD	0,308	----	----	----	----
5535		CAM ÇİTASI PROFİLİ GLAZING BEAD	0,305	----	----	----	----
5536		CAM ÇİTASI PROFİLİ GLAZING BEAD	0,312	----	----	----	----
5537		CAM ÇİTASI PROFİLİ GLAZING BEAD	0,318	----	----	----	----
5538		CAM ÇİTASI PROFİLİ GLAZING BEAD	0,325	----	----	----	----
5539		CAM ÇİTASI PROFİLİ GLAZING BEAD	0,331	----	----	----	----



E 55





PROFİL İNDEKS / PROFILE INDEX

COD Code	PROFİL KESİTİ Profile View	PROFİL AÇIKLAMASI Profile Description	AGIRLIK (kg/m) Weight	Jxx cm ⁴	Jyy cm ⁴	Wxx cm ³	Wyy cm ³
5350		ORTA KAYIT PROFİLİ MULLION PROFILE	2,095	72,89	26,59	9,78	7,13
5351		ORTA KAYIT PROFİLİ MULLION PROFILE	1,910	45,80	21,67	6,51	5,72
5352		KASA PROFİLİ FRAME PROFILE	1,727	41,23	14,91	6,31	4,37
5353		KANAT PROFİLİ SASH PROFILE	1,249	10,50	8,56	3,43	2,50
5588		CAM ÇITASI PROFİLİ GLAZING BEAD	0,521	6,63	1,05	2,00	0,90
5587		CAM ÇITASI PROFİLİ GLAZING BEAD	0,510	6,36	0,82	1,97	0,75
5584		CAM ÇITASI PROFİLİ GLAZING BEAD	0,222	0,86	0,20	0,46	0,05
1756		KÖSE TAKOZ PROFİLİ CORNER JOINT	2,474	----	----	----	----
1885		KÖSE TAKOZ PROFİLİ CORNER JOINT	4,471	----	----	----	----
4550		KÖSE TAKOZ PROFİLİ CORNER JOINT	3,581	----	----	----	----
5127		KÖSE TAKOZ PROFİLİ CORNER JOINT	3,484	----	----	----	----

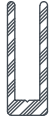

E 55

PROFİL İNDEKS / PROFILE INDEX

COD Code	PROFİL KESİTİ Profile View	PROFİL AÇIKLAMASI Profile Description	AGIRLIK (kg/m) Weight	Jxx cm4	Jyy cm4	Wxx cm3	Wyy cm3
5128		KÖSE TAKOZ PROFİLİ CORNER JOINT	3,652	----	----	----	----
5129		KÖSE TAKOZ PROFİLİ CORNER JOINT	4,618	----	----	----	----
4542		KÖSE TAKOZ PROFİLİ CORNER JOINT	5,381	----	----	----	----
5570		" U " BAG. PROFİLİ " U " LINKING PROFILE	0,393	----	----	----	----
5569		" U " BAG. PROFİLİ " U " LINKING PROFILE	0,555	----	----	----	----
5571		" U " BAG. PROFİLİ " U " LINKING PROFILE	0,772	----	----	----	----

clarks

E 55

PROFİLLER

PROFILES

E 55 - 1.5 - 1.8 - 2.0T YALITIMLI SERİ
E 55 - 1.5 - 1.8 - 2.0T INSULATION SERIES





E 55

PROFİLLER / PROFILES

COD Code	AGIRLIK (kg/m) Weight	Jxx cm4	Jyy cm4	Wxx cm3	Wyy cm3	L m
5317	1,111	14,13	3,50	4,20	1,38	6
5300	1,172	15,20	3,62	4,53	1,42	6
5318	1,427	18,68	9,50	4,95	3,08	6
5301	1,512	20,31	9,95	5,44	3,24	6
5725	1,571	21,41	10,30	5,78	3,73	6

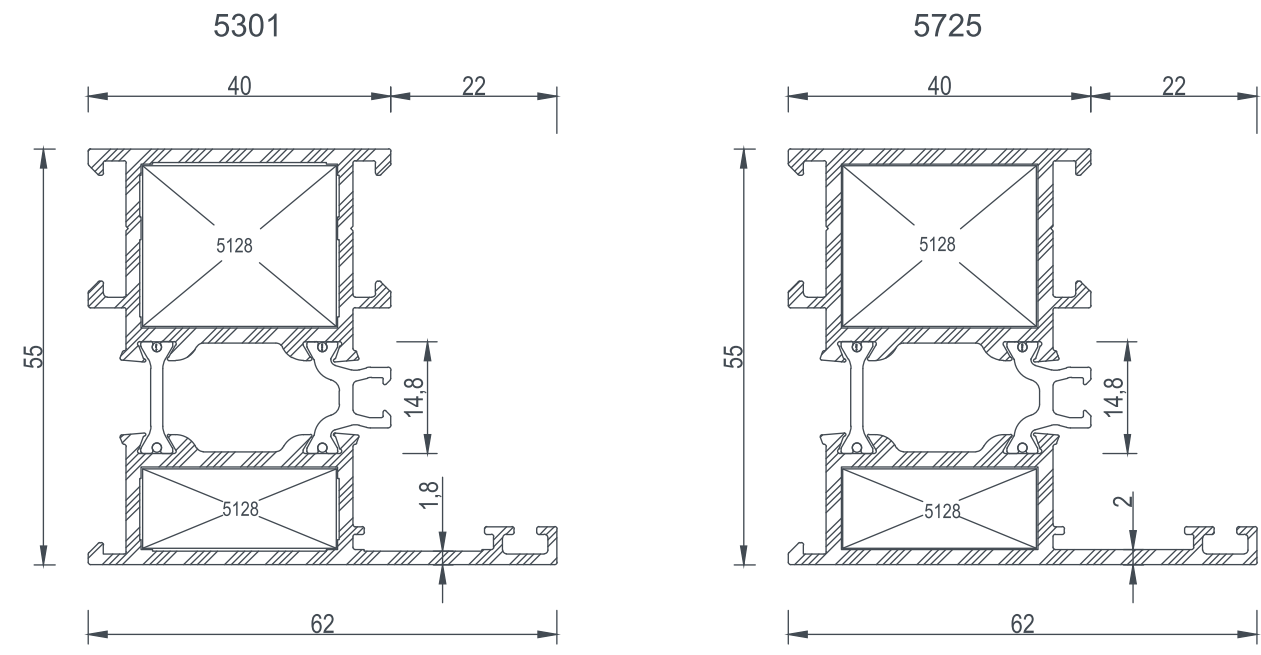
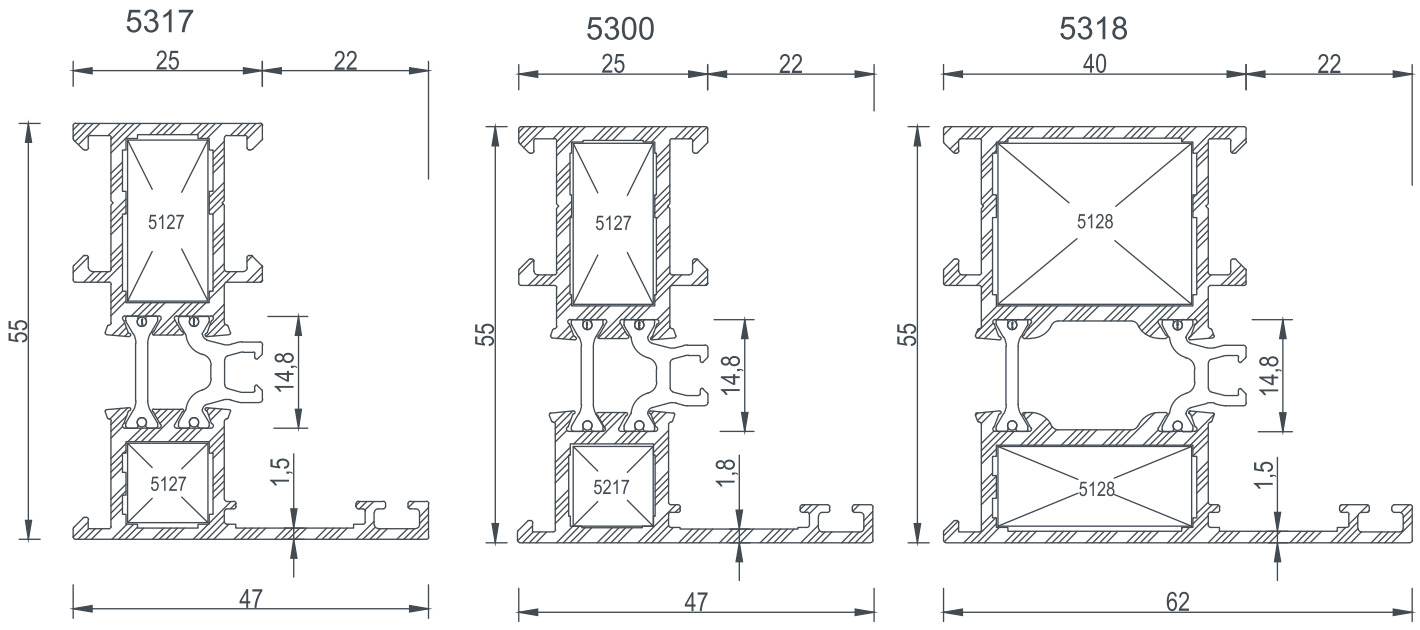



E 55

PROFİLLER / PROFILES

COD Code	AGIRLIK (kg/m) Weight	Jxx cm4	Jyy cm4	Wxx cm3	Wyy cm3	L m
5343	1,311	56,55	27,50	4,75	2,30	6
5345	1,670	37,24	13,17	5,92	3,93	6

5343

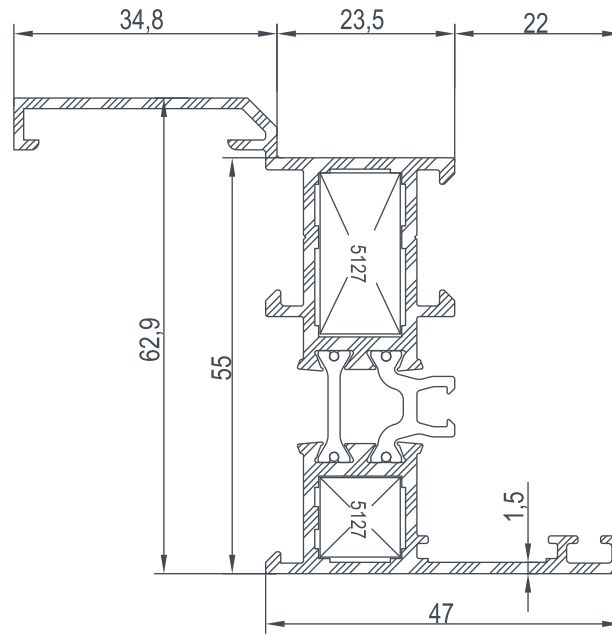

5345

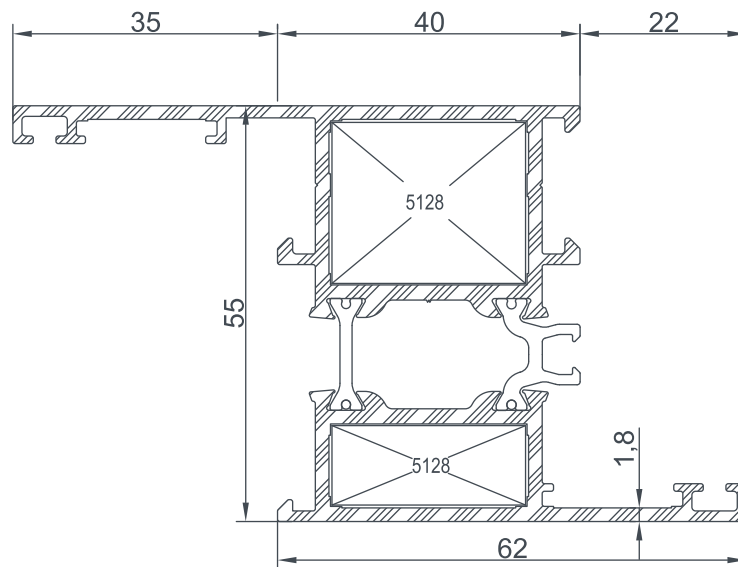

22





E 55

PROFİLLER / PROFILES

COD Code	AGIRLIK (kg/m) Weight	Jxx cm4	Jyy cm4	Wxx cm3	Wyy cm3	L m
5434	1,700	32,76	13,54	7,39	3,85	6
5433	2,079	47,10	29,56	9,18	6,10	6
5319	1,807	30,76	19,90	5,65	5,04	6
5302	1,924	32,90	21,73	6,05	5,46	6

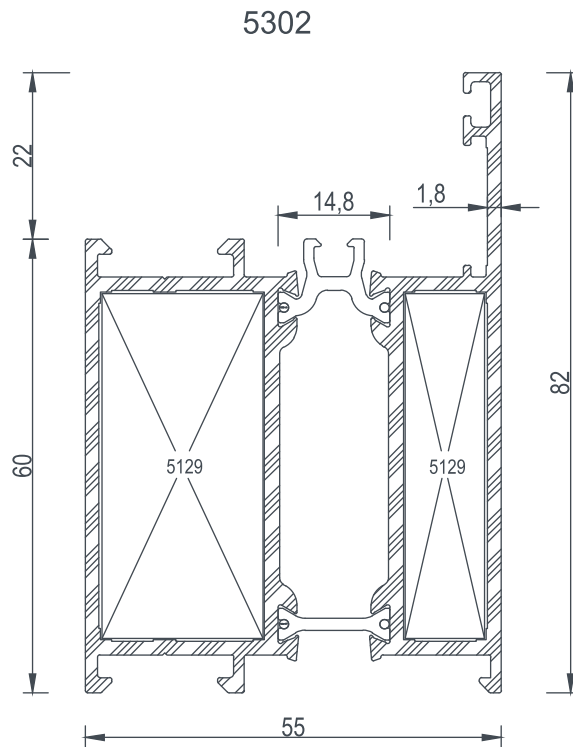
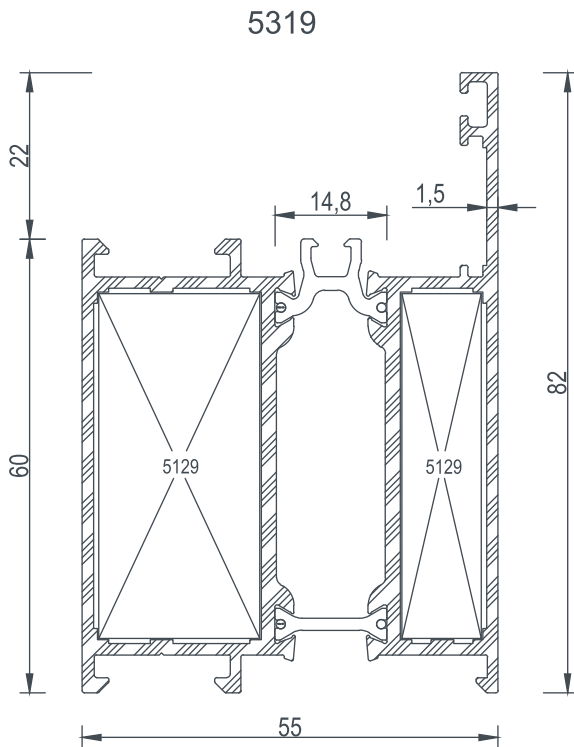
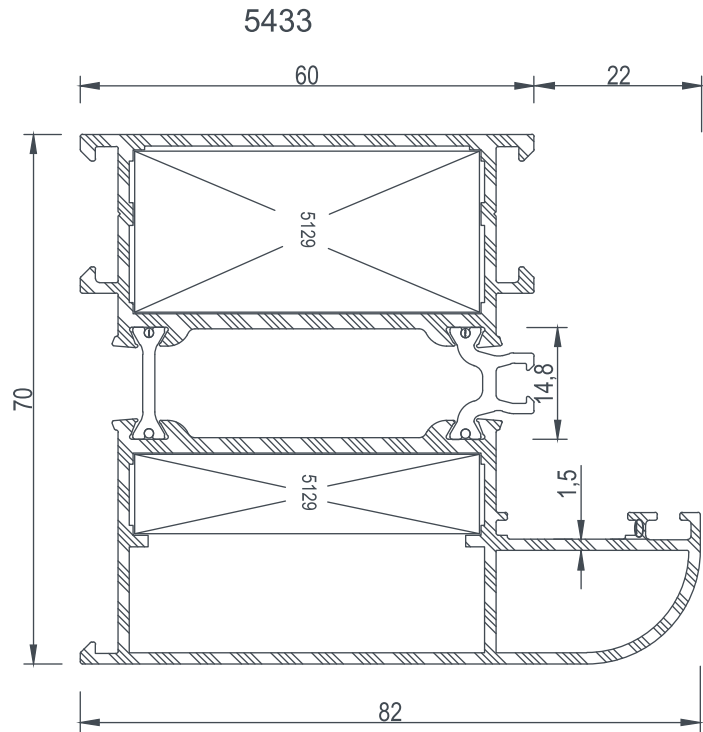
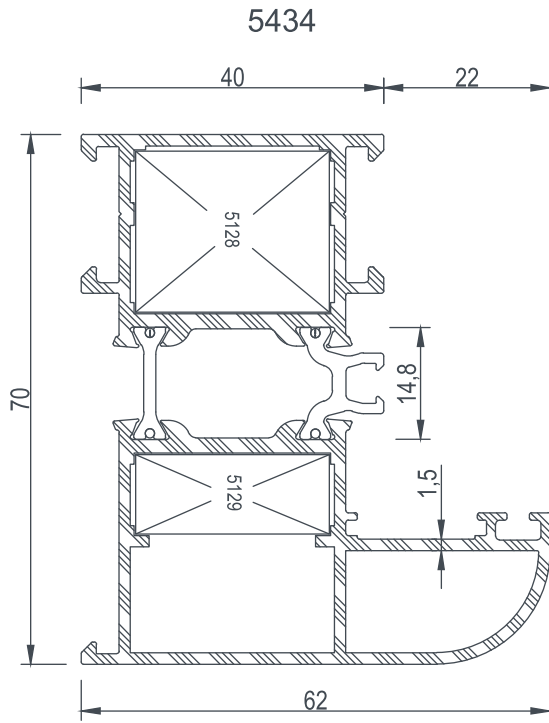



E 55

PROFİLLER / PROFILES

COD Code	AGIRLIK (kg/m) Weight	Jxx cm ⁴	Jyy cm ⁴	Wxx cm ³	Wyy cm ³	L m
5320	1,352	24,59	3,60	5,76	1,87	6
5303	1,446	26,75	3,82	6,24	1,92	6
5321	1,700	32,15	10,29	6,77	3,48	6
5304	1,784	35,33	11,38	7,49	3,93	6

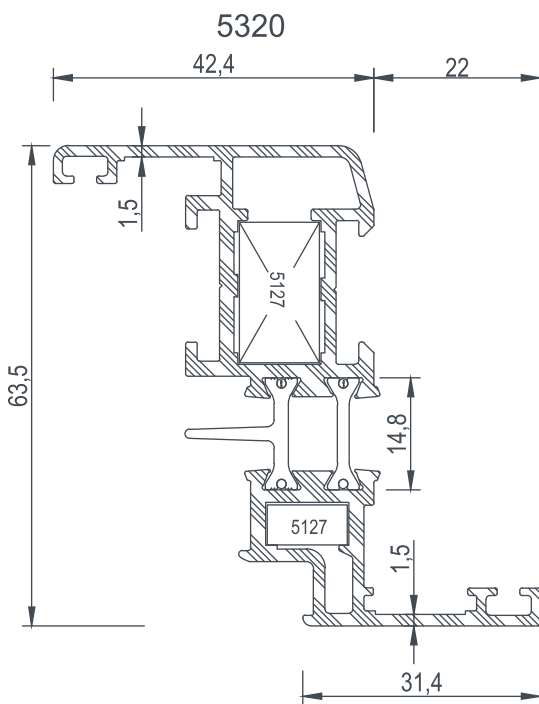

5321

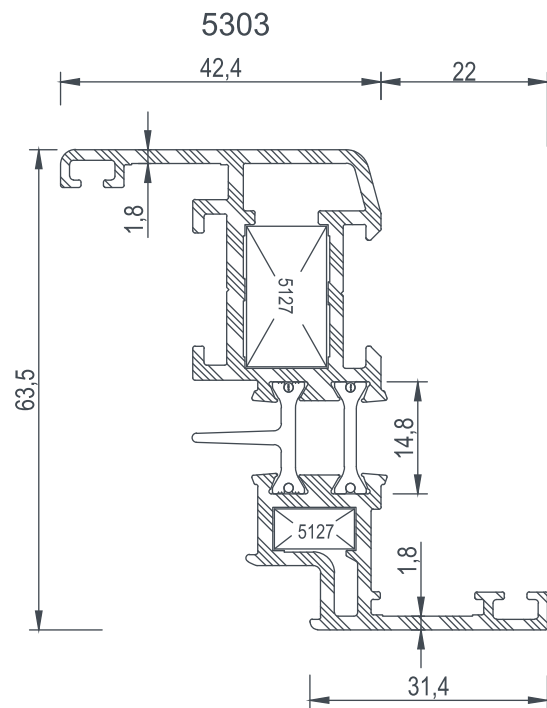

5304

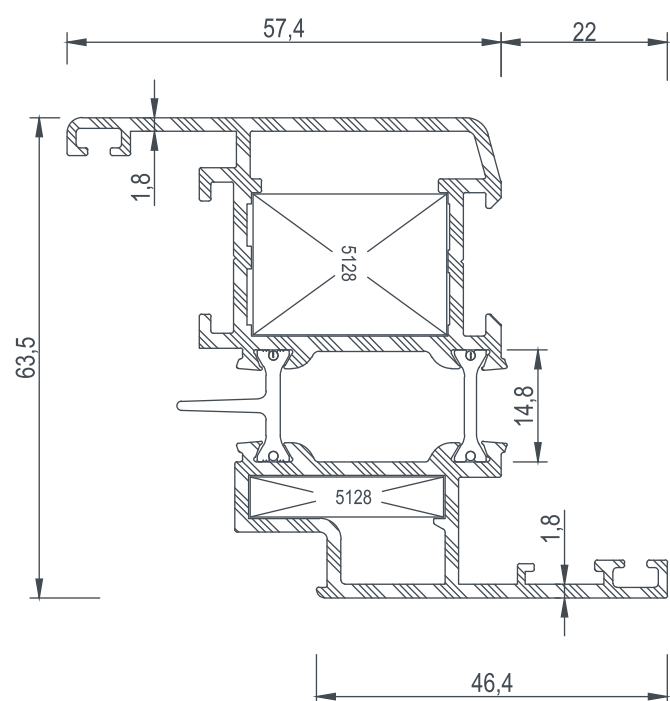
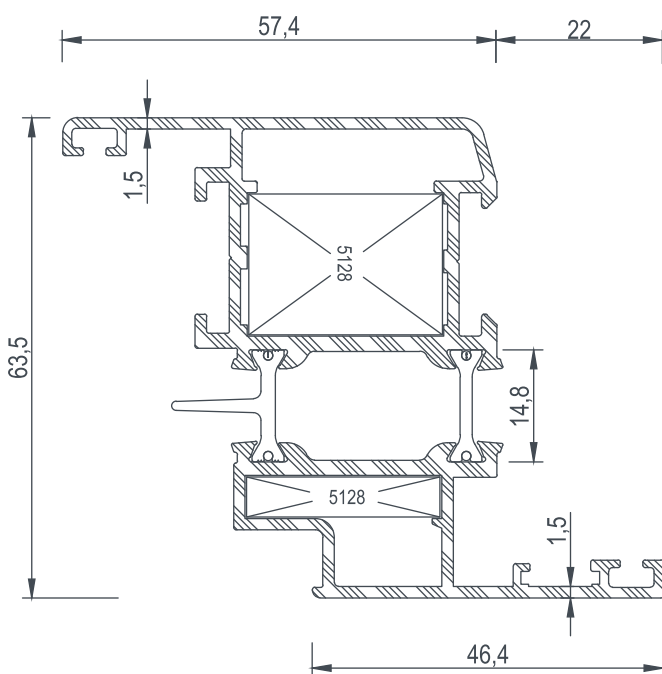



E 55

PROFİLLER / PROFILES

COD Code	AGIRLIK (kg/m) Weight	Jxx cm ⁴	Jyy cm ⁴	Wxx cm ³	Wyy cm ³	L m
5711	1,828	37,46	10,88	7,83	3,83	6
5340	1,595	30,67	8,62	6,51	3,12	6
5577	2,064	49,25	21,41	8,58	5,41	6

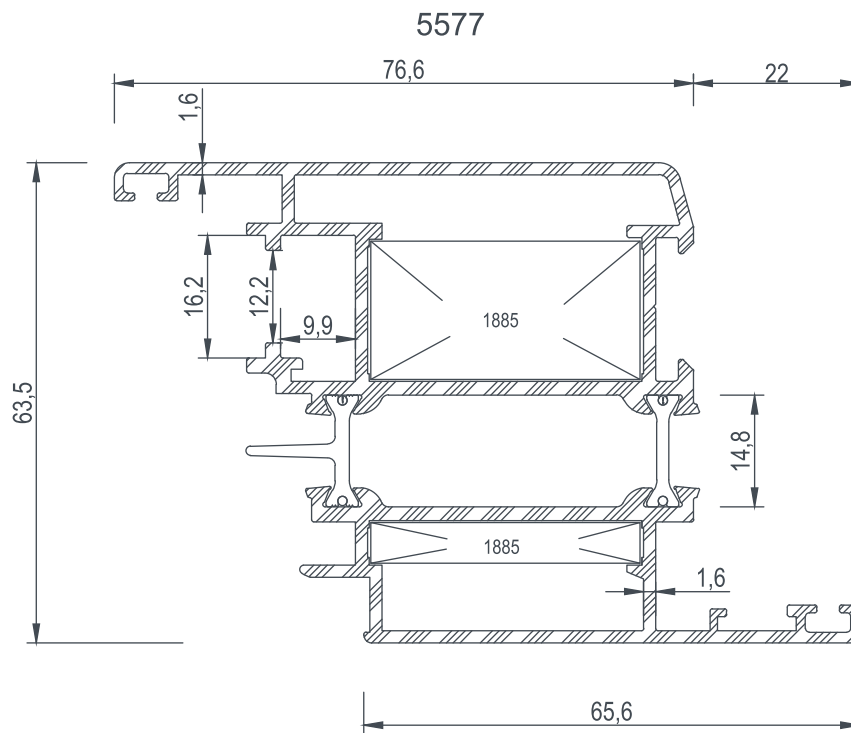
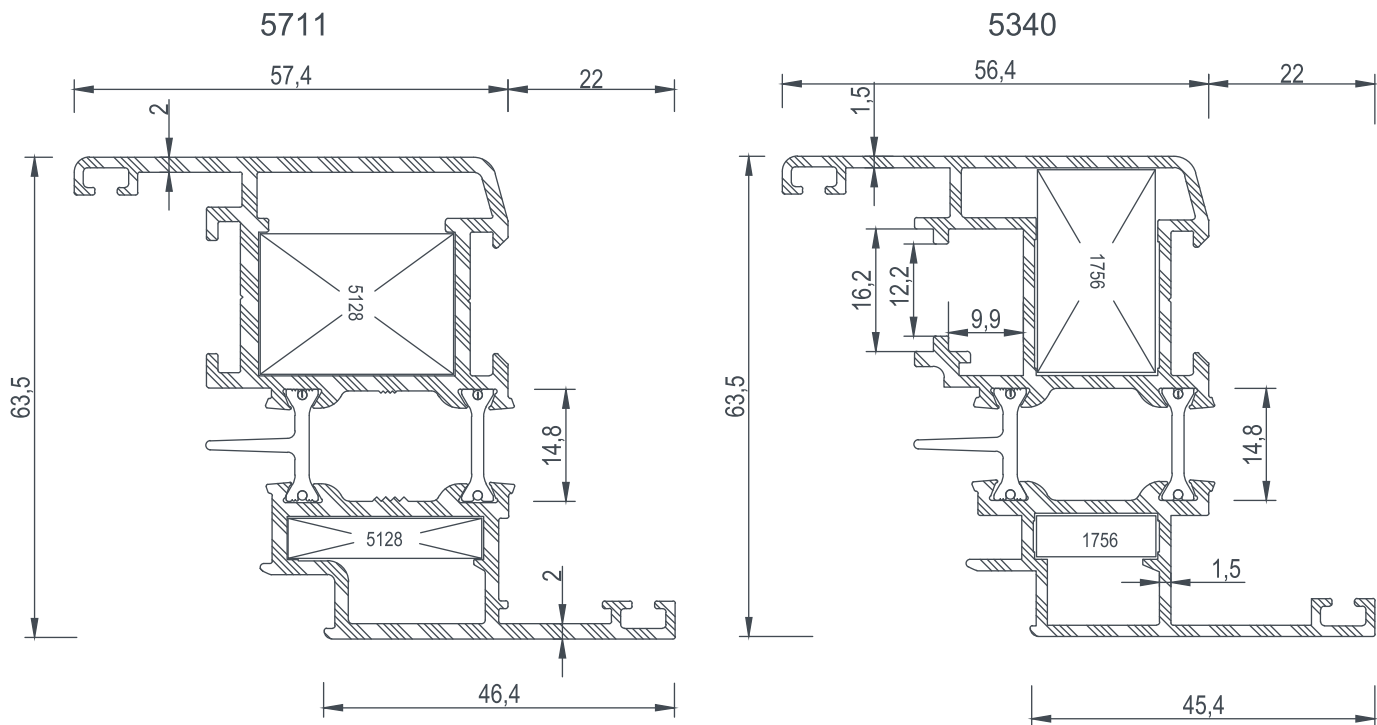



E 55

PROFİLLER / PROFILES

COD Code	AGIRLIK (kg/m) Weight	Jxx cm ⁴	Jyy cm ⁴	Wxx cm ³	Wyy cm ³	L m
5333	2,005	42,51	15,98	8,26	4,74	6
5714	1,859	38,88	11,34	8,26	4,06	6
5334	2,573	74,37	35,08	11,47	8,19	6

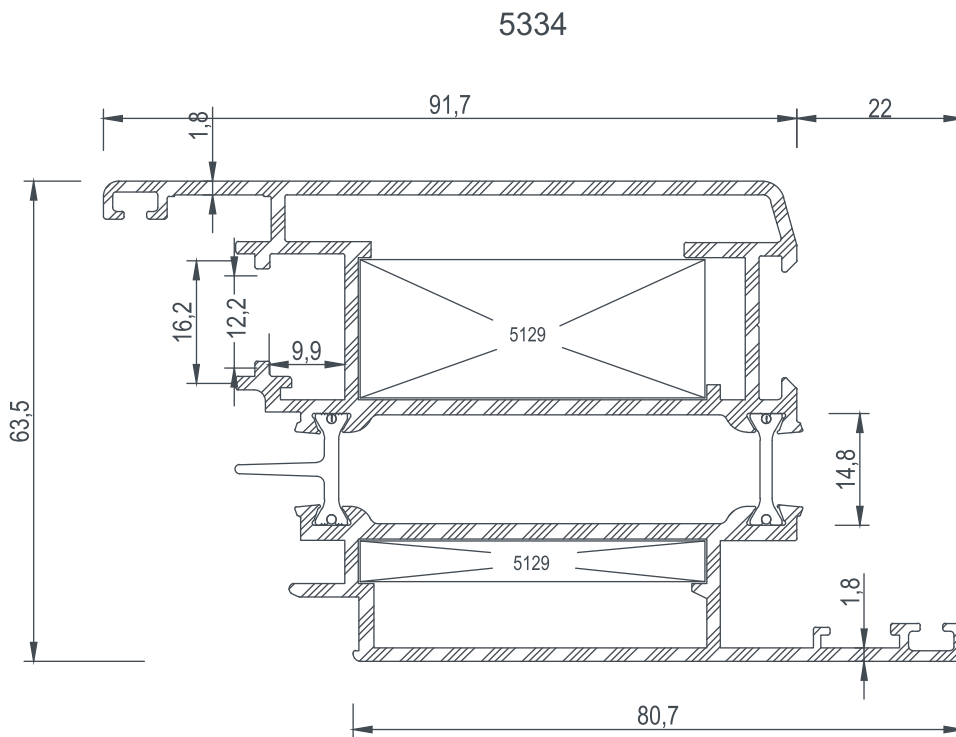
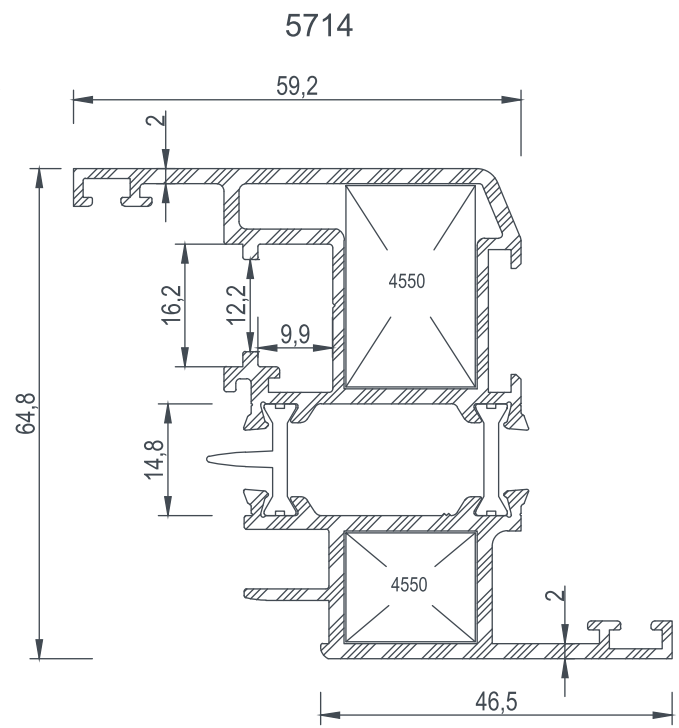
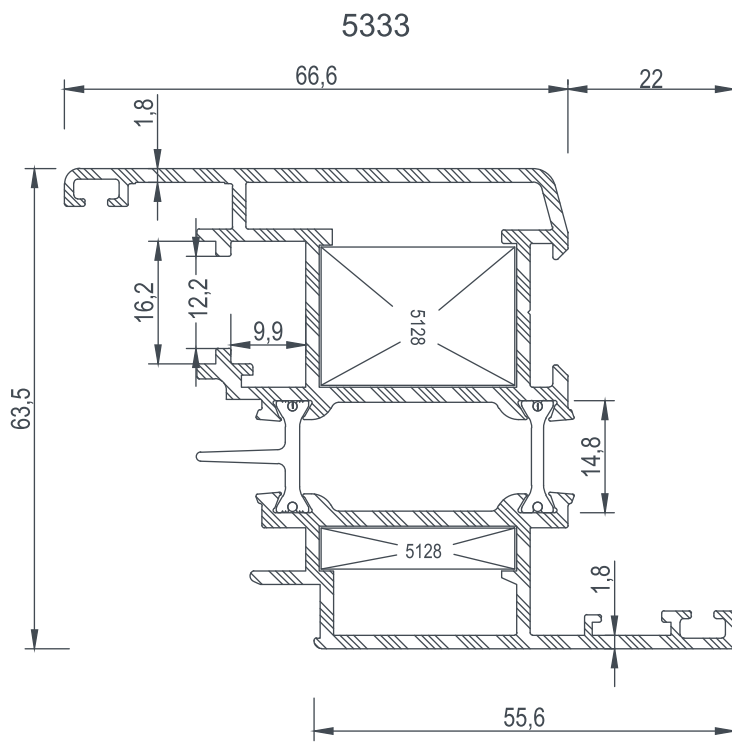



E 55

PROFİLLER / PROFILES

COD Code	AGIRLIK (kg/m) Weight	Jxx cm ⁴	Jyy cm ⁴	Wxx cm ³	Wyy cm ³	L m
5567	2,333	70,94	30,80	10,92	7,11	6
5564	2,498	75,11	34,97	11,45	8,03	6

5567

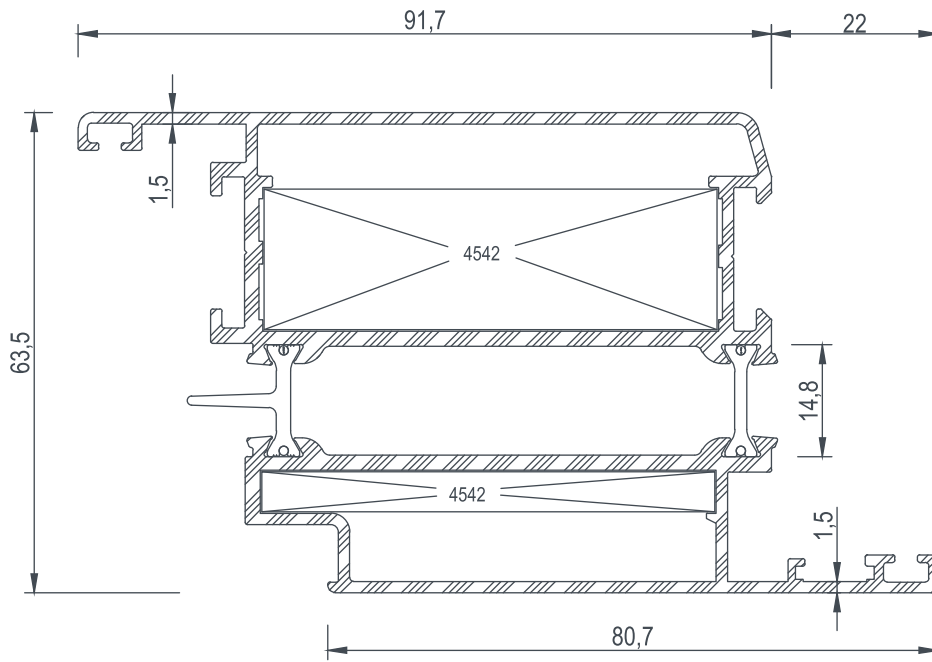

5564

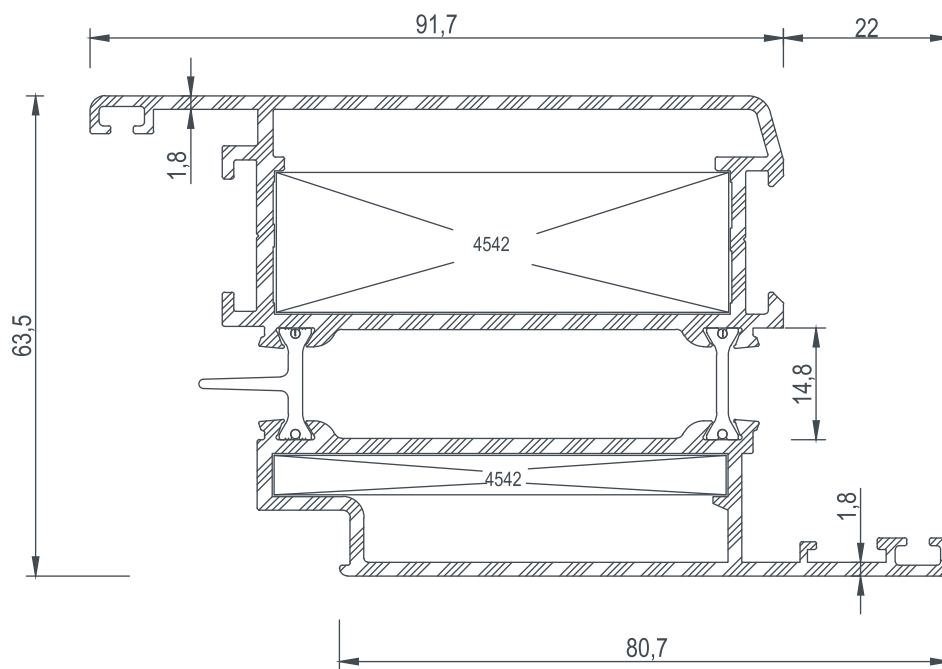



E 55

PROFİLLER / PROFILES

COD Code	AGIRLIK (kg/m) Weight	Jxx cm4	Jyy cm4	Wxx cm3	Wyy cm3	L m
5712	2,577	78,82	35,68	8,03	11,45	6
5323	2,126	44,40	33,17	8,68	9,50	6
5306	2,308	48,32	37,50	9,59	10,44	6

5712

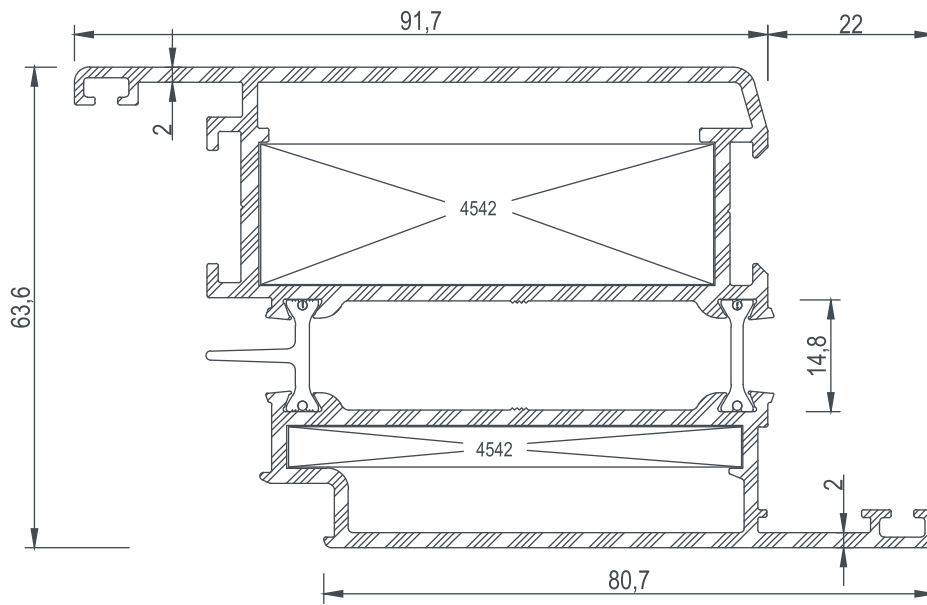

5323

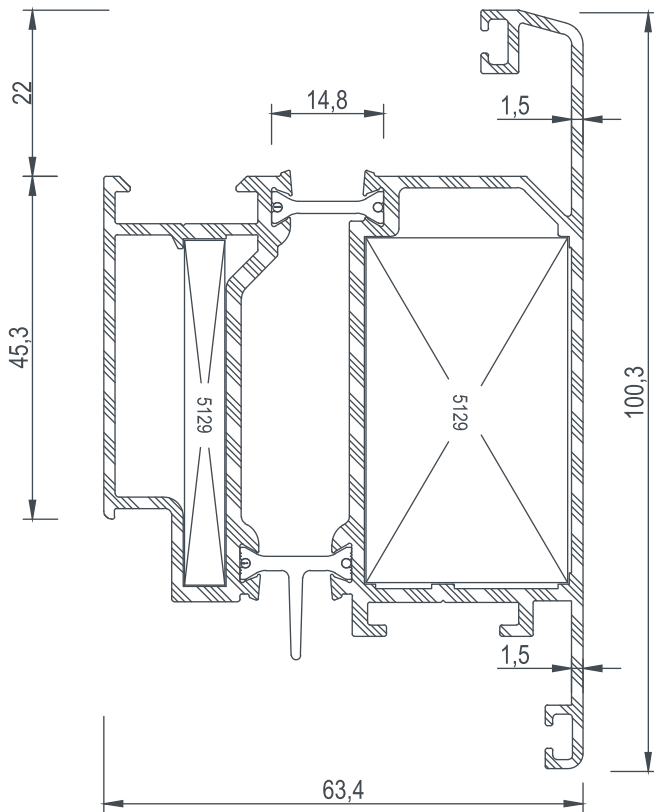

5306

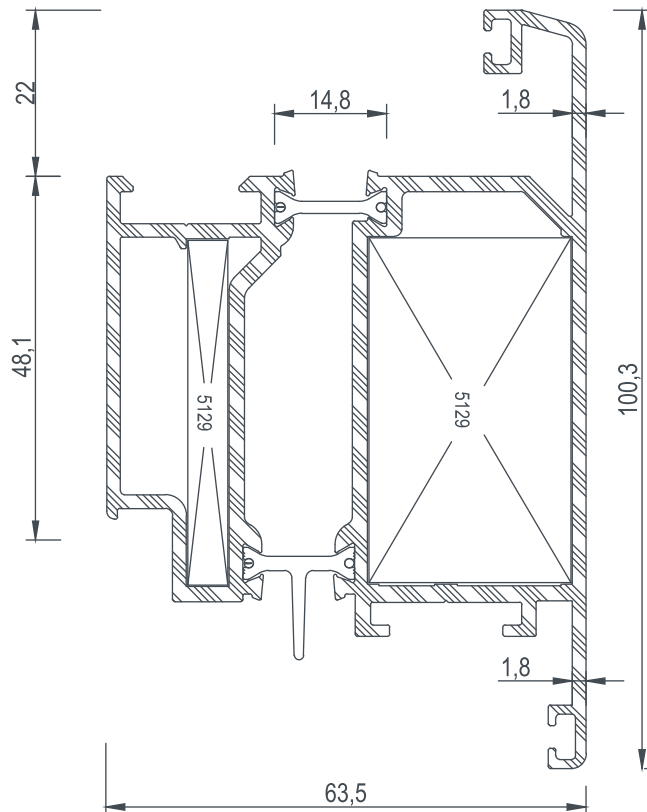



E 55

PROFİLLER / PROFILES

COD Code	AGIRLIK (kg/m) Weight	Jxx cm ⁴	Jyy cm ⁴	Wxx cm ³	Wyy cm ³	L m
5324	1,275	15,62	7,63	4,68	2,21	6
5307	1,344	16,78	7,96	5,03	2,30	6
5325	1,588	19,43	16,53	5,92	3,93	6
5308	1,684	21,22	17,37	6,48	4,13	6

5324

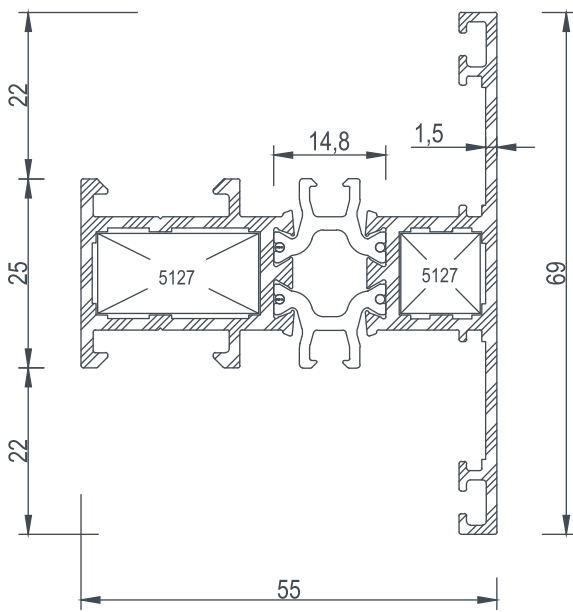

5307

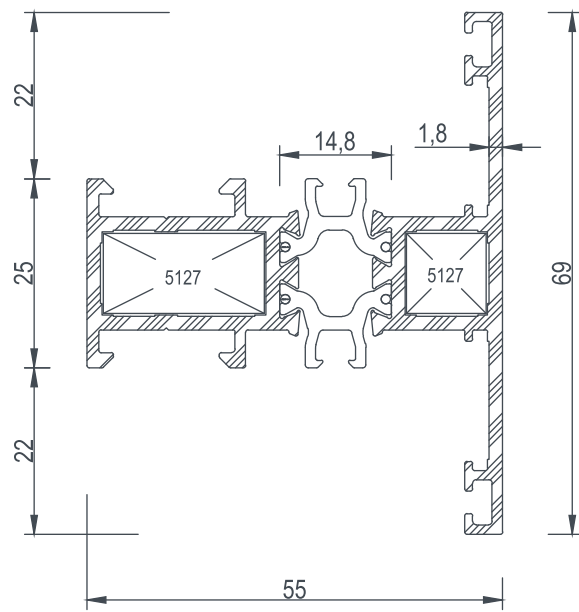

5325

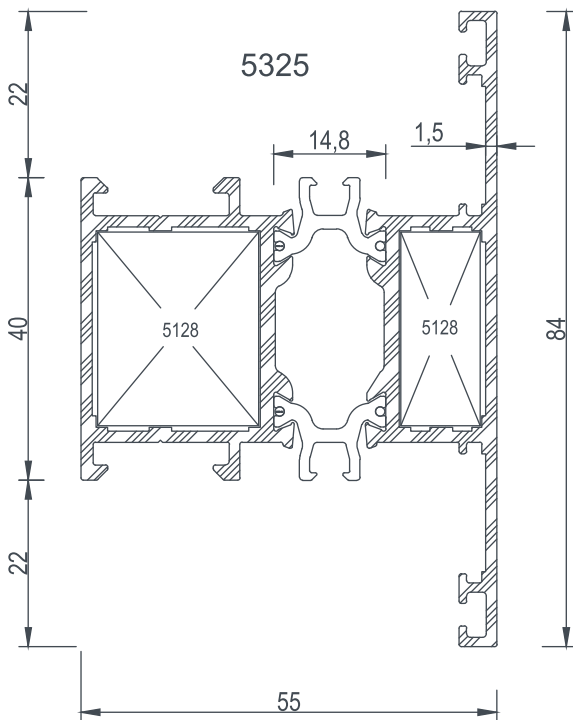

5308

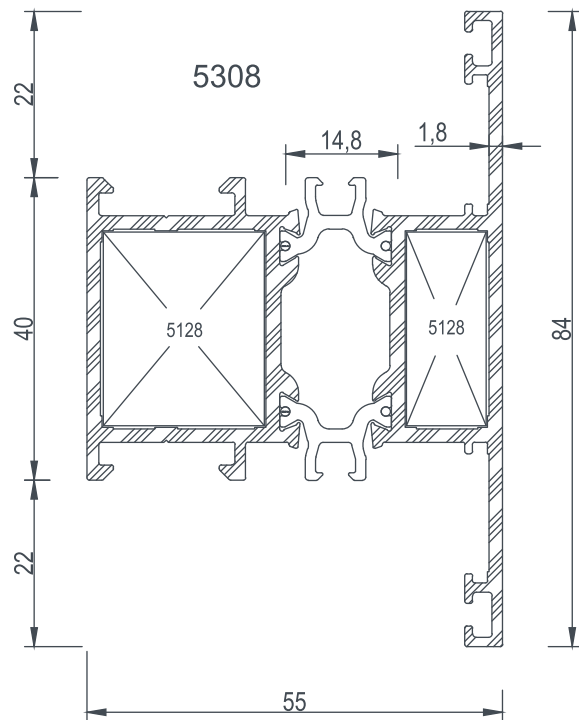



E 55

PROFILLER / PROFILES

COD Code	AGIRLIK (kg/m) Weight	Jxx cm4	Jyy cm4	Wxx cm3	Wyy cm3	L m
5713	1,753	22,44	17,95	6,85	4,27	6
5327	1,667	20,77	16,89	6,56	4,02	6
5310	1,757	22,50	17,71	7,10	4,21	6
5326	1,970	37,77	24,42	7,26	7,55	6

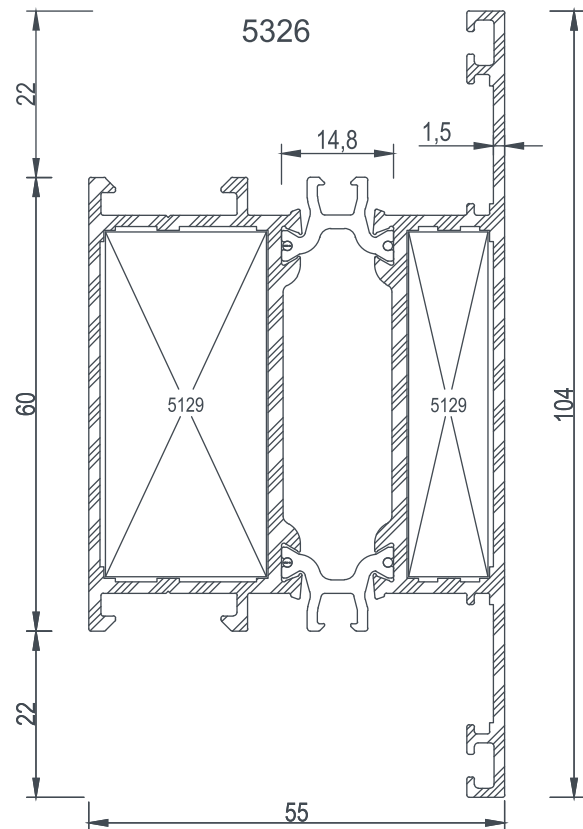
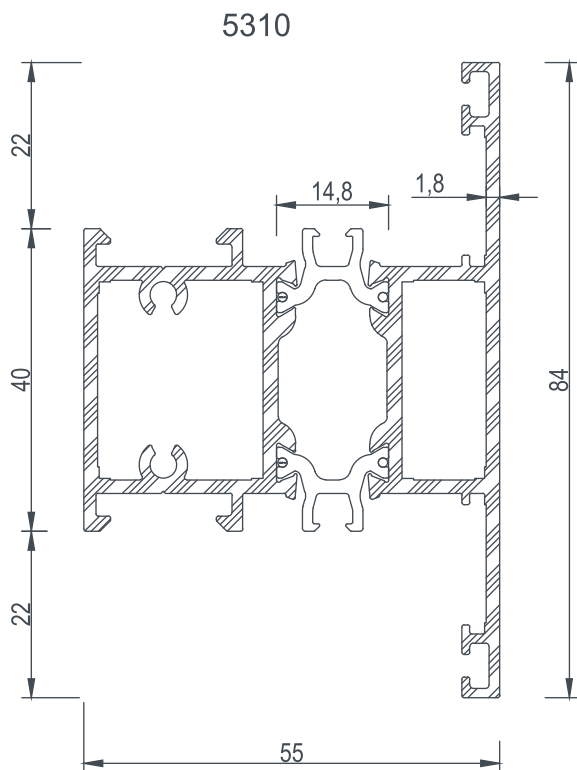
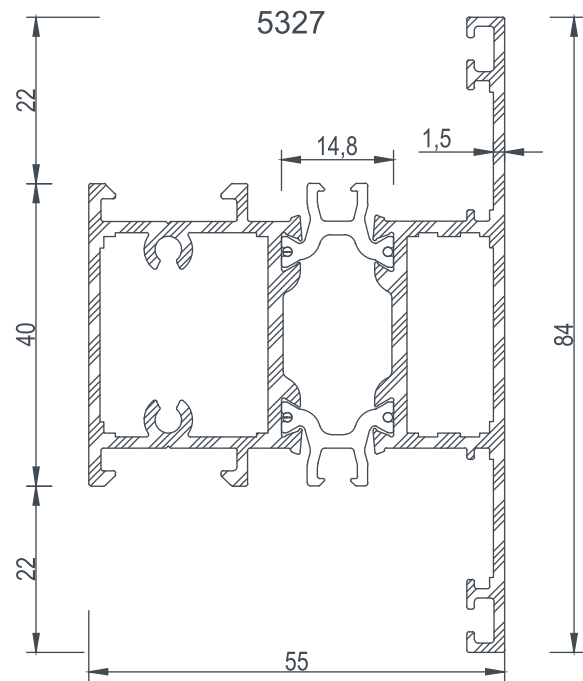
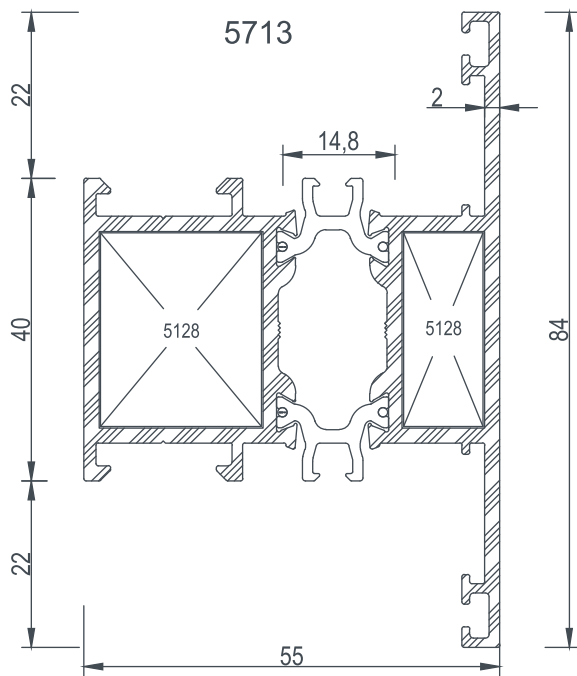



E 55

PROFILLER / PROFILES

COD Code	AGIRLIK (kg/m) Weight	Jxx cm4	Jyy cm4	Wxx cm3	Wyy cm3	L m
5309	2,096	39,90	27,04	7,67	8,39	6
5328	2,188	72,24	26,66	12,92	6,34	6
5311	2,398	82,25	29,33	15,05	6,98	6

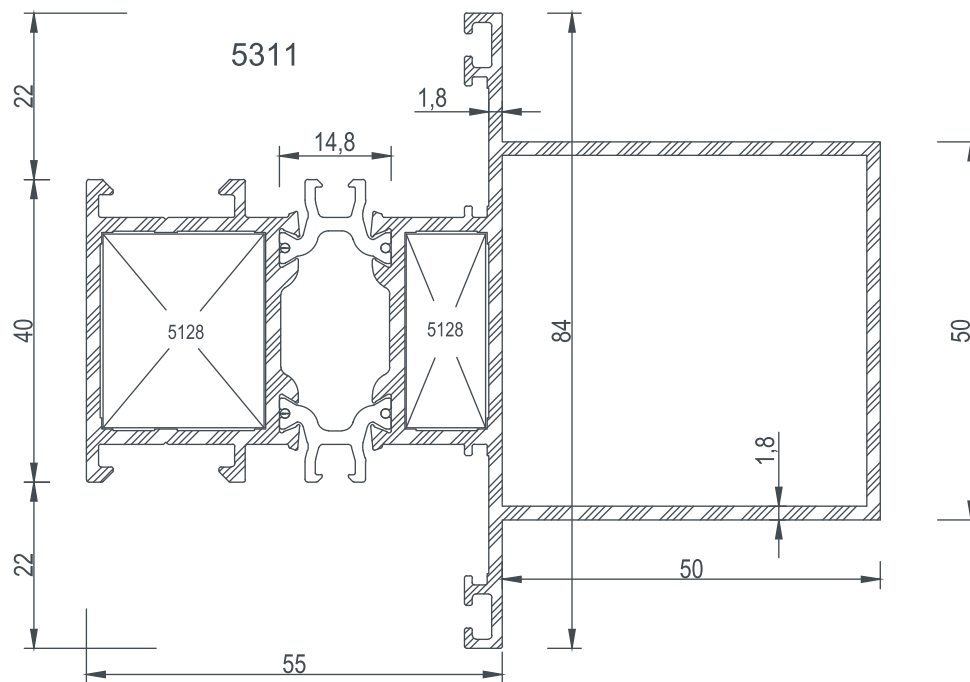
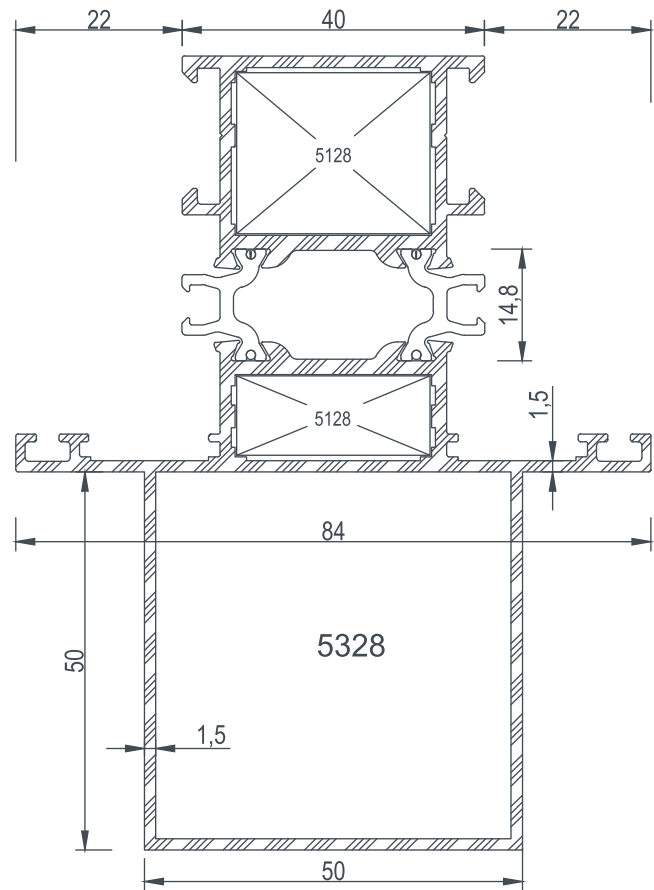
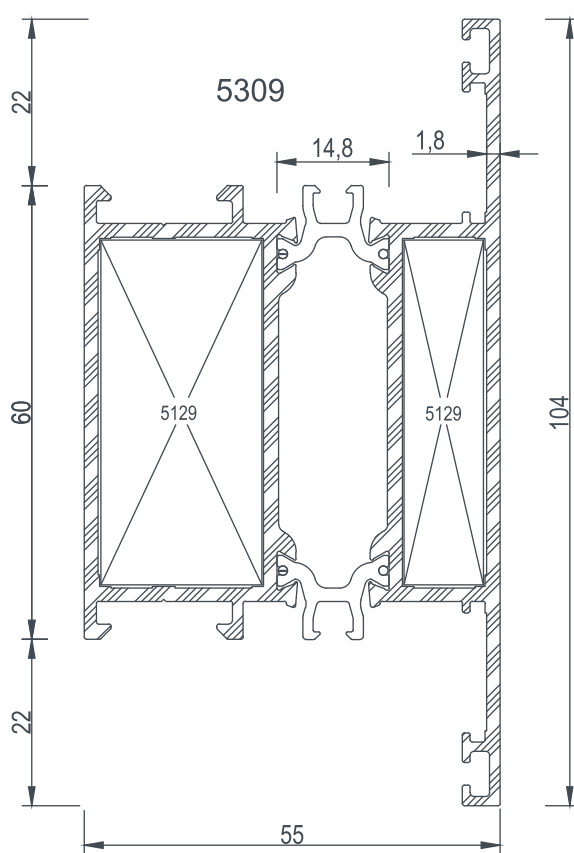

31





E 55

PROFILLER / PROFILES

COD Code	AGIRLIK (kg/m) Weight	Jxx cm ⁴	Jyy cm ⁴	Wxx cm ³	Wyy cm ³	L m
5329	2,381	115,43	24,50	14,58	5,83	6
5312	2,600	127,17	26,77	16,27	6,37	6

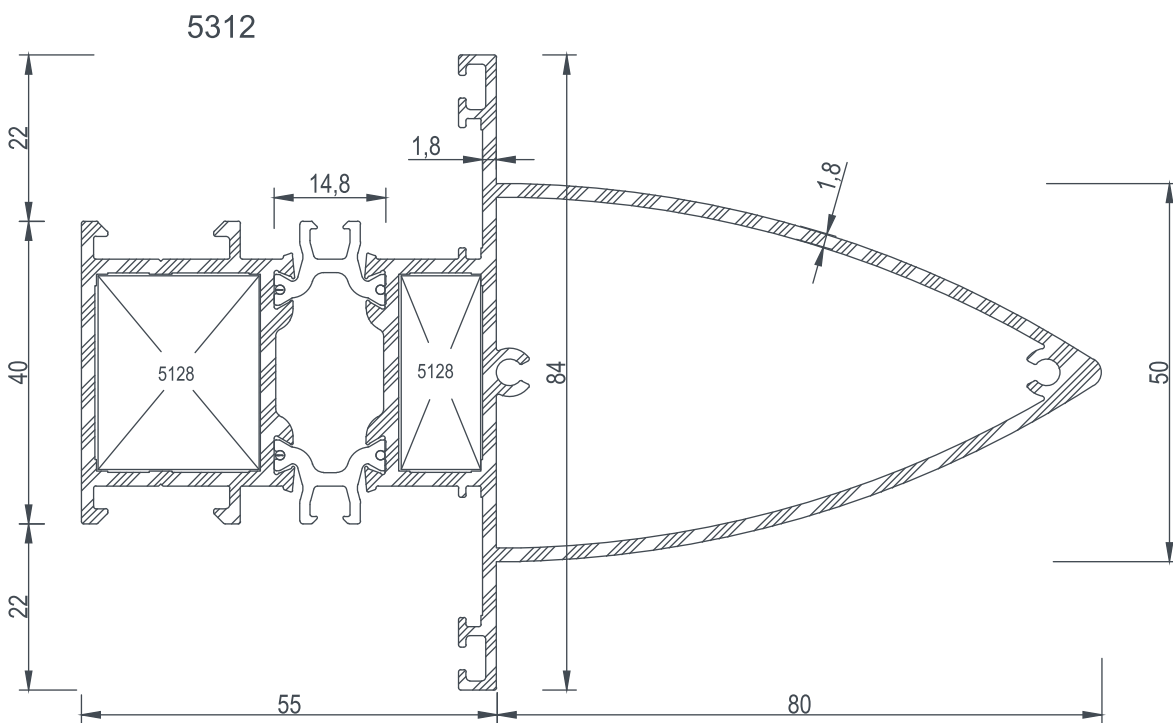
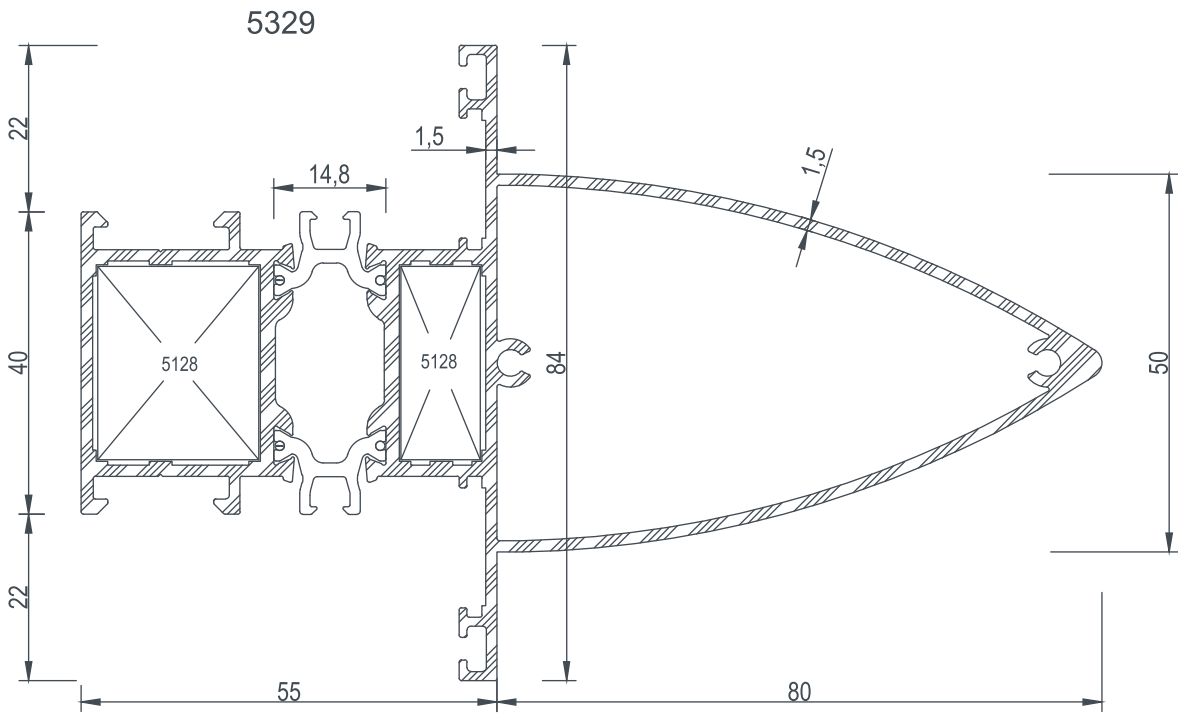

32





E 55

PROFILLER / PROFILES

COD Code	AGIRLIK (kg/m) Weight	Jxx cm4	Jyy cm4	Wxx cm3	Wyy cm3	L m
5330	2,314	77,44	30,91	11,81	8,66	6
5313	2,505	85,03	35,10	12,83	9,81	6
5710	2,640	90,26	37,90	13,53	10,60	6

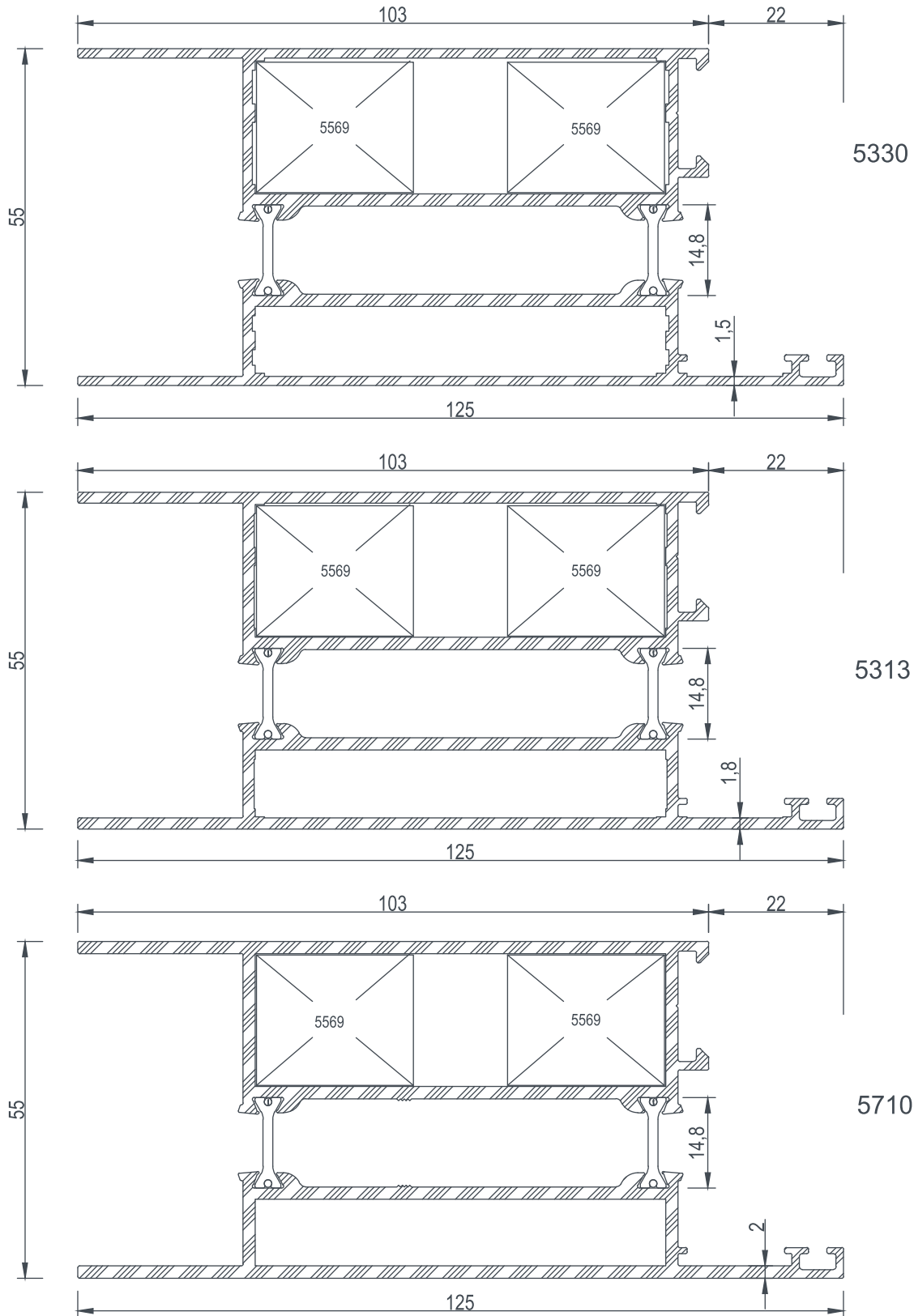

33





E 55

PROFILLER / PROFILES

COD Code	AGIRLIK (kg/m) Weight	Jxx cm4	Jyy cm4	Wxx cm3	Wyy cm3	L m
5331	1,326	15,38	7,55	4,10	2,28	6
5314	1,403	16,20	8,13	4,22	2,40	6
5332	1,352	18,31	8,85	4,92	2,68	6
5315	1,461	20,00	9,88	5,54	3,10	6
5335	1,142	12,39	5,27	4,01	1,94	6

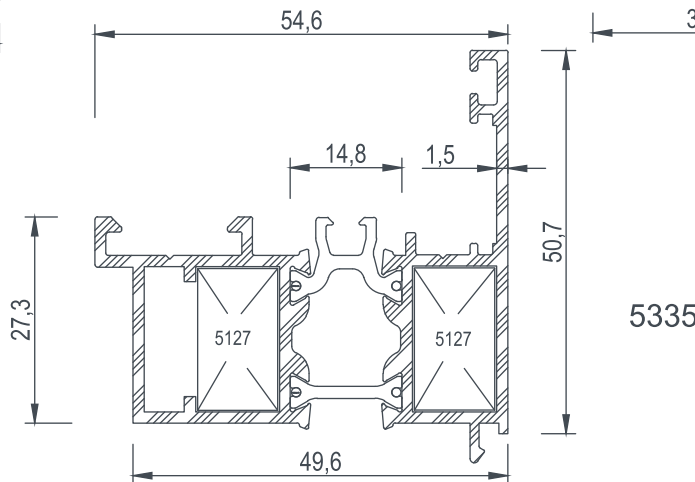
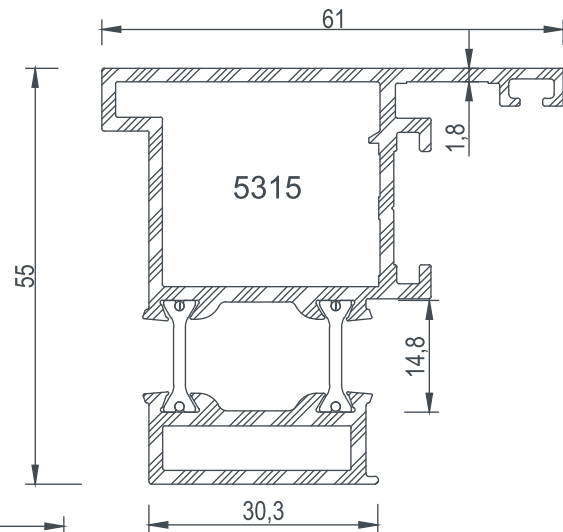
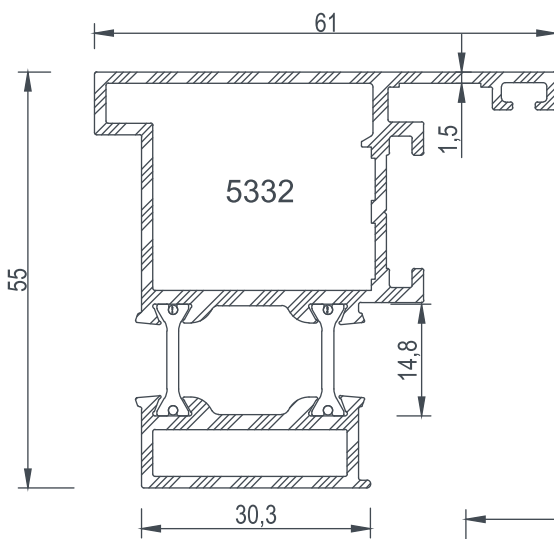
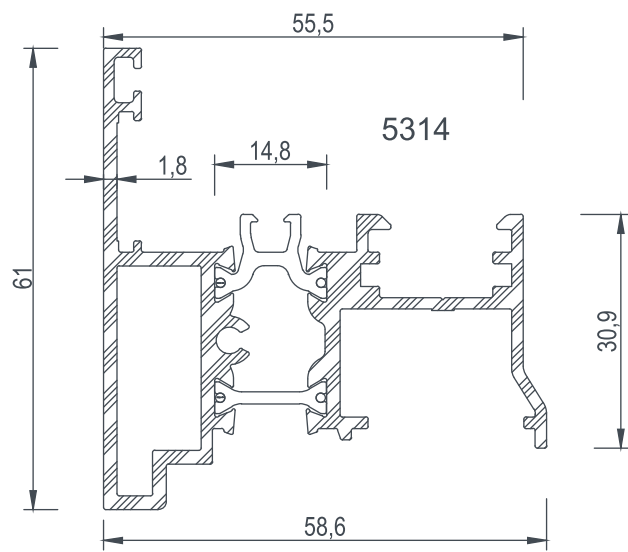
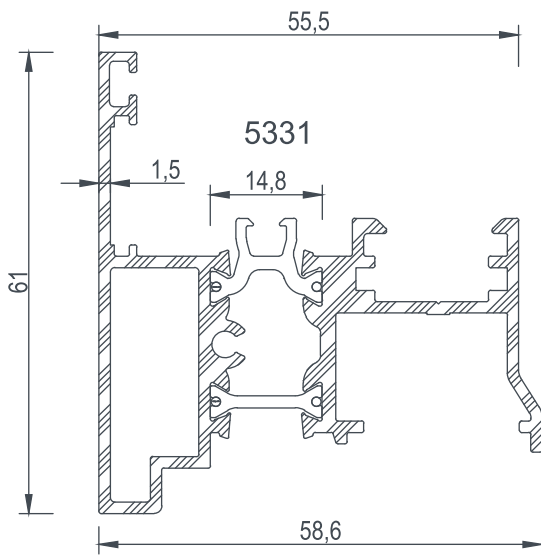



E 55

PROFİLLER / PROFILES

COD Code	AGIRLIK (kg/m) Weight	Jxx cm4	Jyy cm4	Wxx cm3	Wyy cm3	L m
5316	1,987	40,77	34,30	7,78	6,83	6
5117	0,105	----	----	----	----	6
5336	1,100	8,33	7,71	3,34	3,08	6
5337	0,151	----	----	----	----	6
5338	0,258	1,63	0,06	0,65	0,08	6
5339	0,374	5,31	0,40	1,59	0,29	6
5572	0,100	----	----	----	----	6
5344	1,277	14,94	8,08	4,25	2,20	6

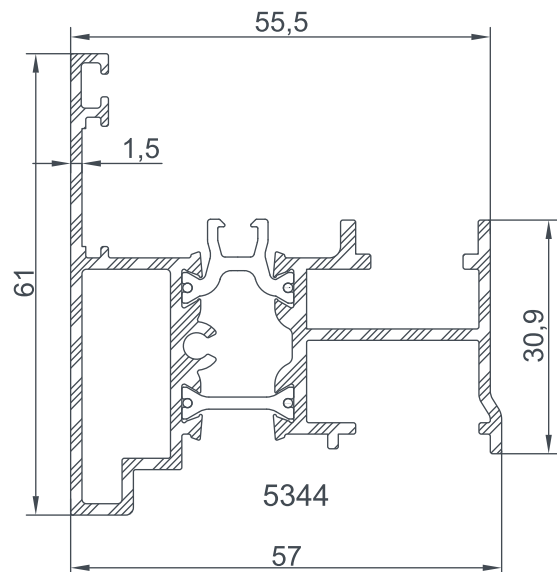
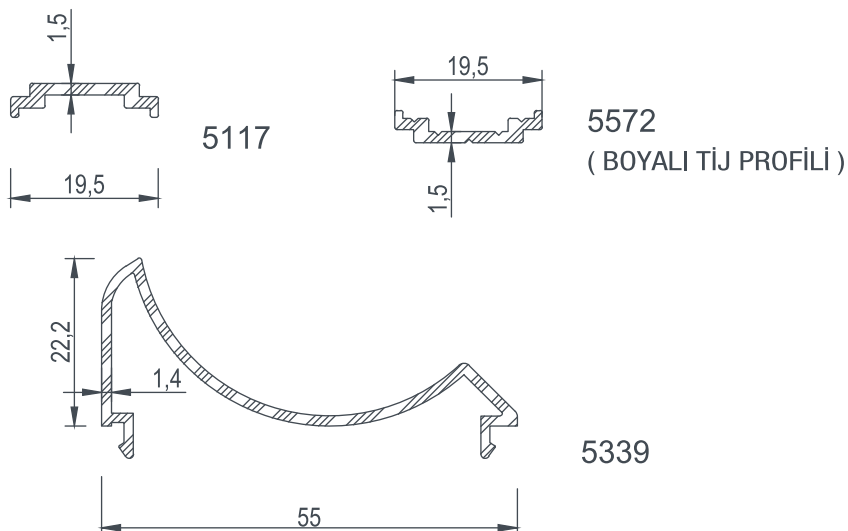
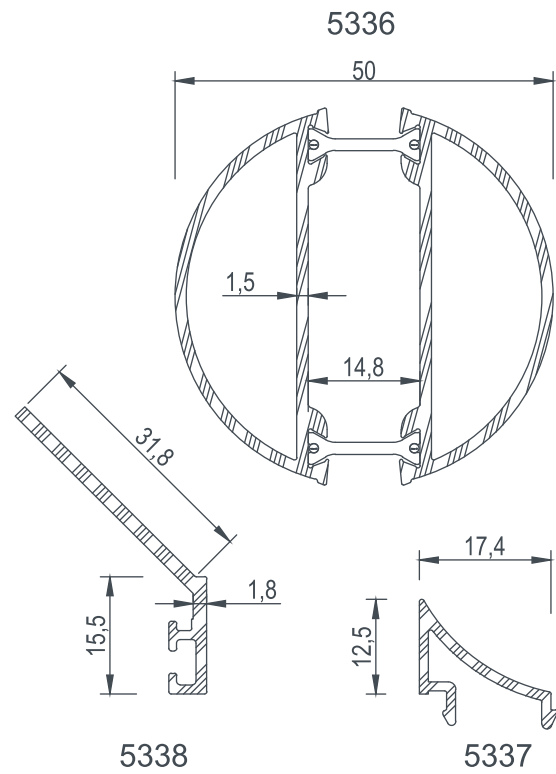
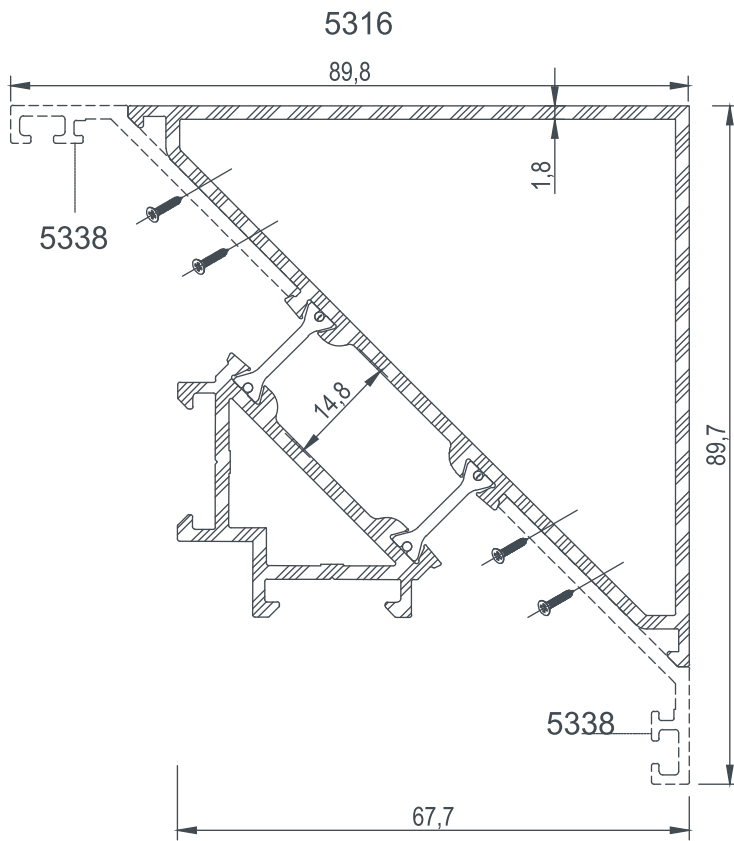



E 55

PROFİLLER / PROFILES

COD Code	AGIRLIK (kg/m) Weight	Jxx cm4	Jyy cm4	Wxx cm3	Wyy cm3	L m
5118	0,249	-----	-----	-----	-----	6
5119	0,251	-----	-----	-----	-----	6
5120	0,255	-----	-----	-----	-----	6
5121	0,260	-----	-----	-----	-----	6
5122	0,267	-----	-----	-----	-----	6
5123	0,274	-----	-----	-----	-----	6
5124	0,281	-----	-----	-----	-----	6
5125	0,292	-----	-----	-----	-----	6
5126	0,308	-----	-----	-----	-----	6
5535	0,305	-----	-----	-----	-----	6

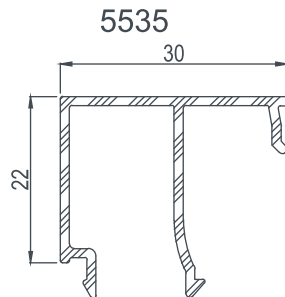
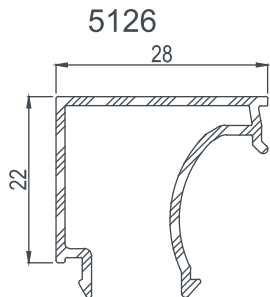
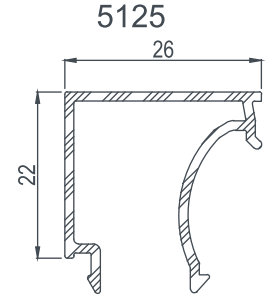
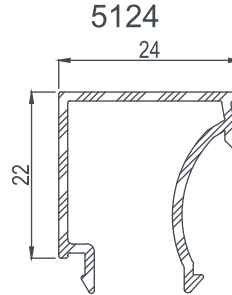
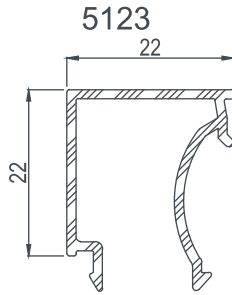
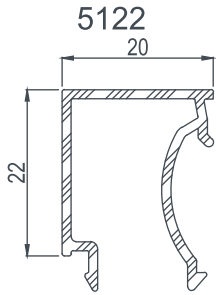
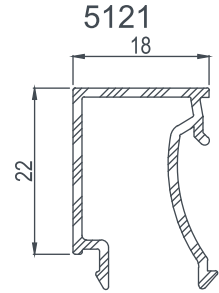
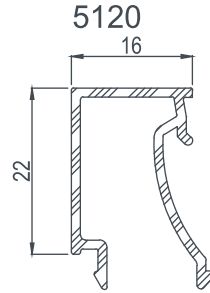
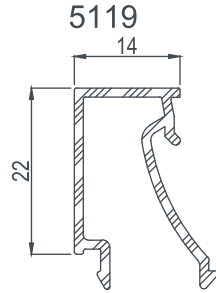
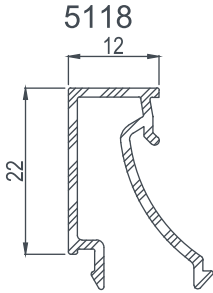

CAM ÇİTASI Glazing Bead	İÇ CAM FİTİLİ Glazing Gasket (in)	CAM KALINLIĞI Glas Thickness	DIŞ CAM FİTİLİ Glazing Gasket (out)
5118	E-01-027	30mm	E-01-028
5119	E-01-027	28mm	E-01-028
5120	E-01-027	26mm	E-01-028
5121	E-01-027	24mm	E-01-028
5122	E-01-027	22mm	E-01-028
5123	E-01-027	20mm	E-01-028
5124	E-01-027	18mm	E-01-028
5125	E-01-027	16mm	E-01-028
5126	E-01-027	14mm	E-01-028
5535	E-01-027	12mm	E-01-028



E 55

PROFİLLER / PROFILES

COD Code	AGIRLIK (kg/m) Weight	Jxx cm4	Jyy cm4	Wxx cm3	Wyy cm3	L m
5536	0,312	-----	-----	-----	-----	6
5537	0,318	-----	-----	-----	-----	6
5538	0,325	-----	-----	-----	-----	6
5539	0,331	-----	-----	-----	-----	6

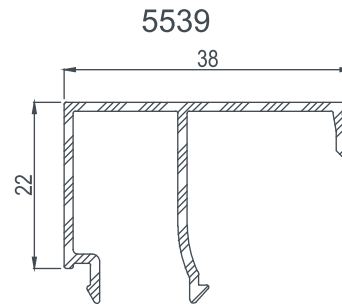
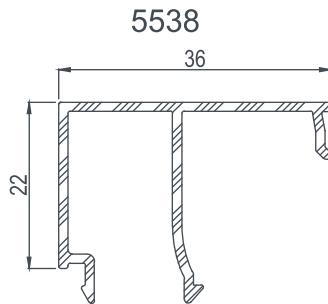
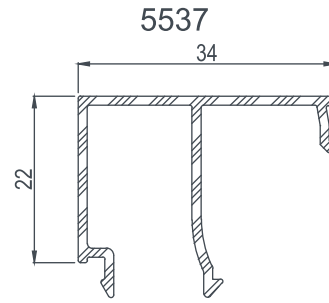
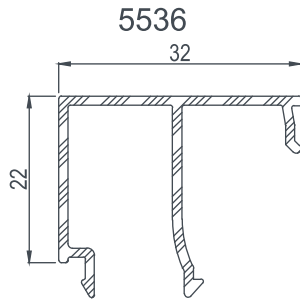

CAM ÇİTASI Glazing Bead	İÇ CAM FİTİLİ Glazing Gasket (in)	CAM KALINLIĞI Glas Thickness	DIŞ CAM FİTİLİ Glazing Gasket (out)
5536	E-01-027	10mm	E-01-028
5537	E-01-027	8mm	E-01-028
5538	E-01-027	6mm	E-01-028
5539	E-01-027	4mm	E-01-028



clarks

E 55

PROFİLLER

PROFILES

GİZLİ KANAT PROFİLİ E 55 - 2.0T
SECRET SASH PROFILE E 55 - 2.0T





E 55

PROFILLER / PROFILES

COD Code	AGIRLIK (kg/m) Weight	Jxx cm4	Jyy cm4	Wxx cm3	Wyy cm3	L m
5350	2,095	72,89	26,59	9,78	7,13	6
5351	1,910	45,80	21,67	6,51	5,72	6

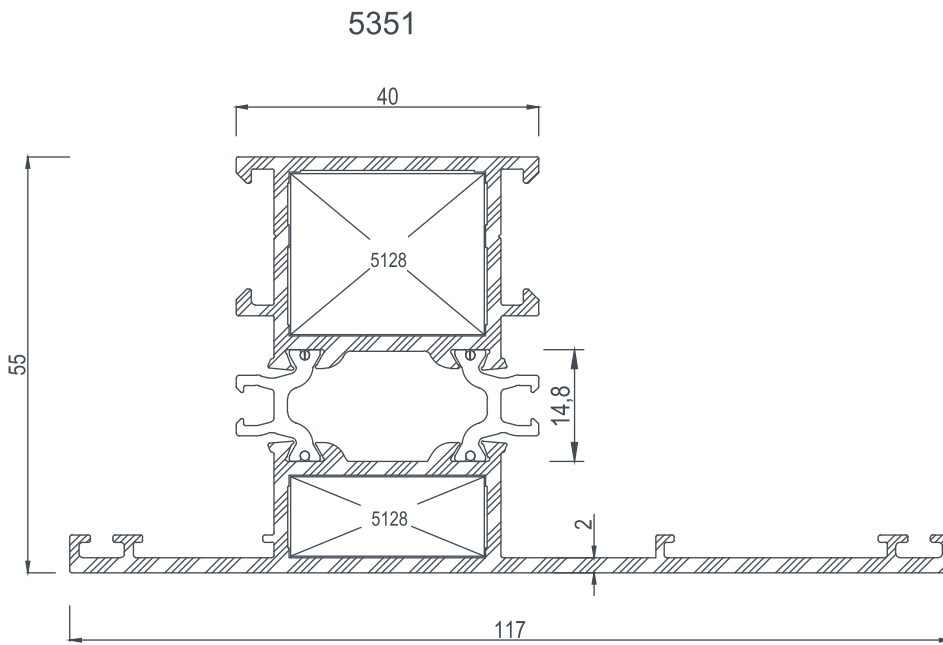
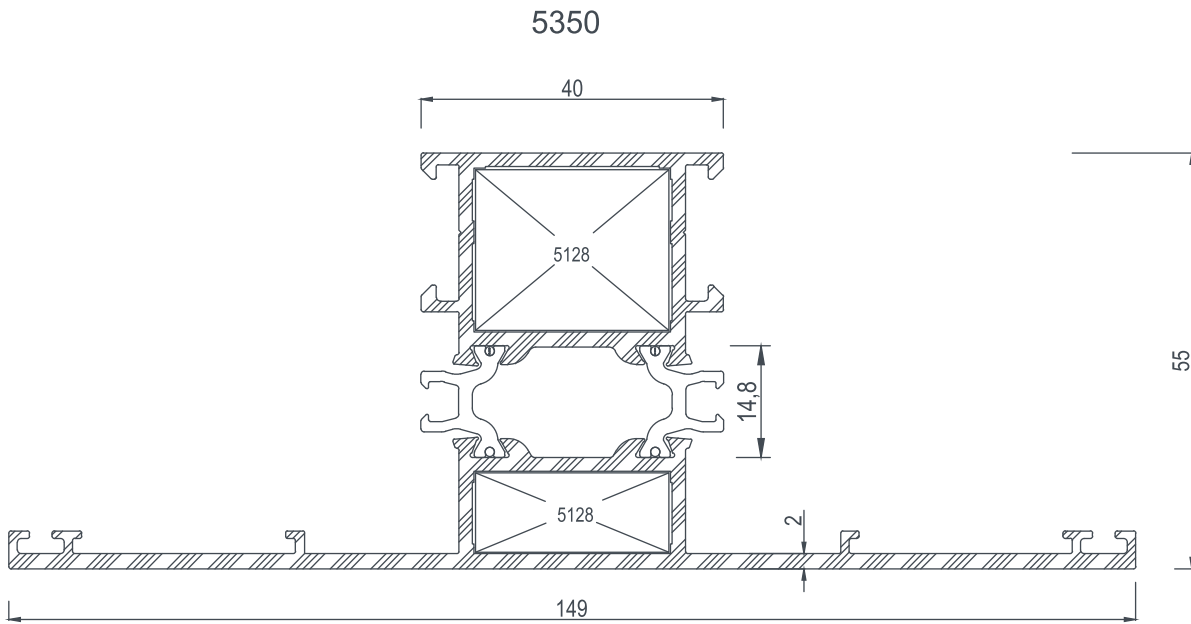



E 55

PROFILLER / PROFILES

COD Code	AGIRLIK (kg/m) Weight	Jxx cm4	Jyy cm4	Wxx cm3	Wyy cm3	L m
5352	1,727	41,23	14,91	6,31	4,37	6
5353	1,249	10,50	8,56	3,43	2,50	6

5352

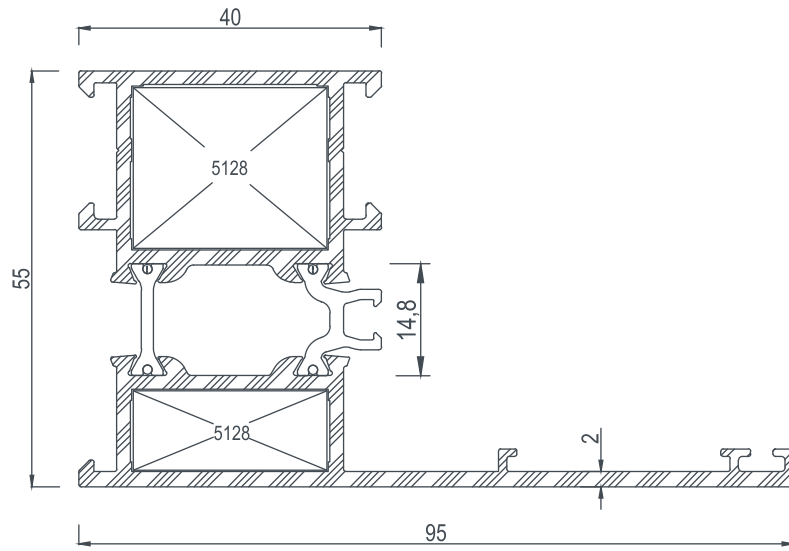

5353

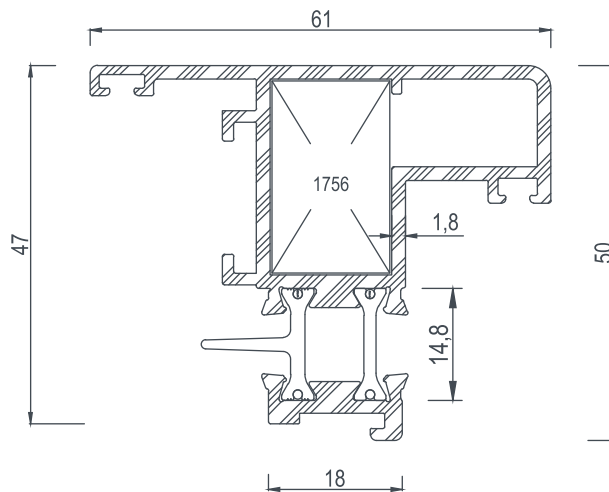



E 55

PROFİLLER / PROFILES

COD Code	AGIRLIK (kg/m) Weight	Jxx cm4	Jyy cm4	Wxx cm3	Wyy cm3	L m
5588	0,521	6,63	1,05	2,00	0,90	6
5587	0,510	6,36	0,82	1,97	0,75	6
5584	0,222	0,86	0,20	0,46	0,05	6

5588

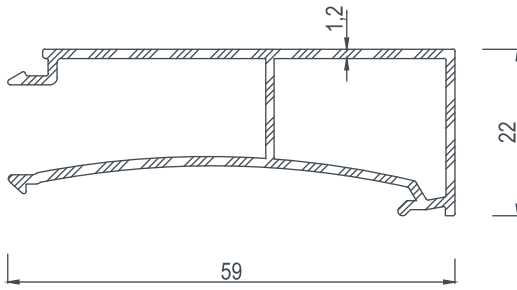

5587

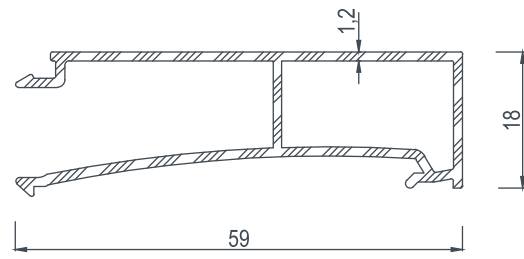

5584

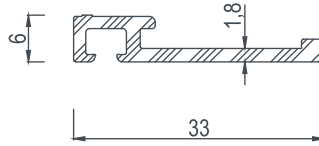

CAM ÇITASI Glazing Bead	İÇ CAM FİTİLİ Glazing Gasket (in)	CAM KALINLIĞI Glas Thickness	DIŞ CAM FİTİLİ Glazing Gasket (out)
5587	E-01-027	24 mm	E-01-028
5588	E-01-027	20 mm	E-01-028



E 55

PROFİLLER / PROFILES

COD Code	AGIRLIK (kg/m) Weight	Jxx cm ⁴	Jyy cm ⁴	Wxx cm ³	Wyy cm ³	L m
1756	2,474	---	---	---	---	6
1885	4,471	---	---	---	---	6
4550	3,581	---	---	---	---	6

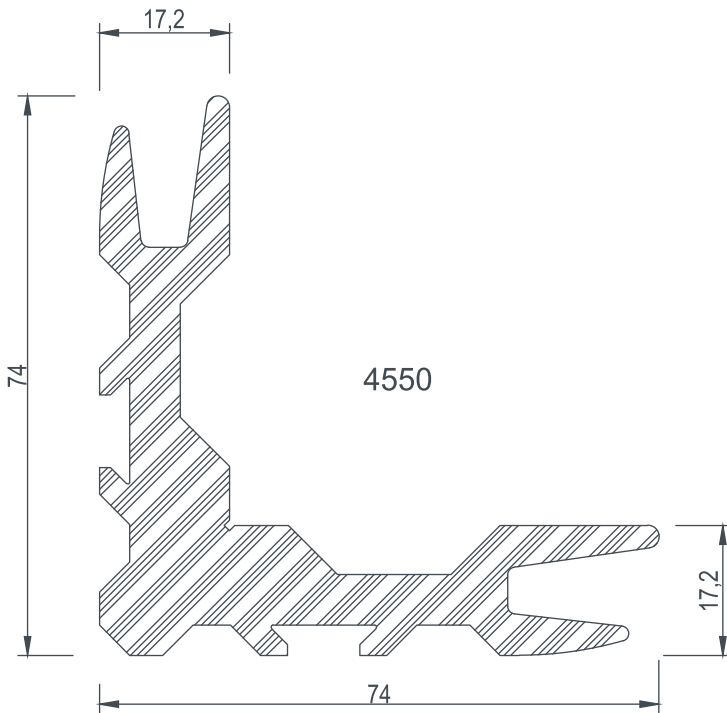
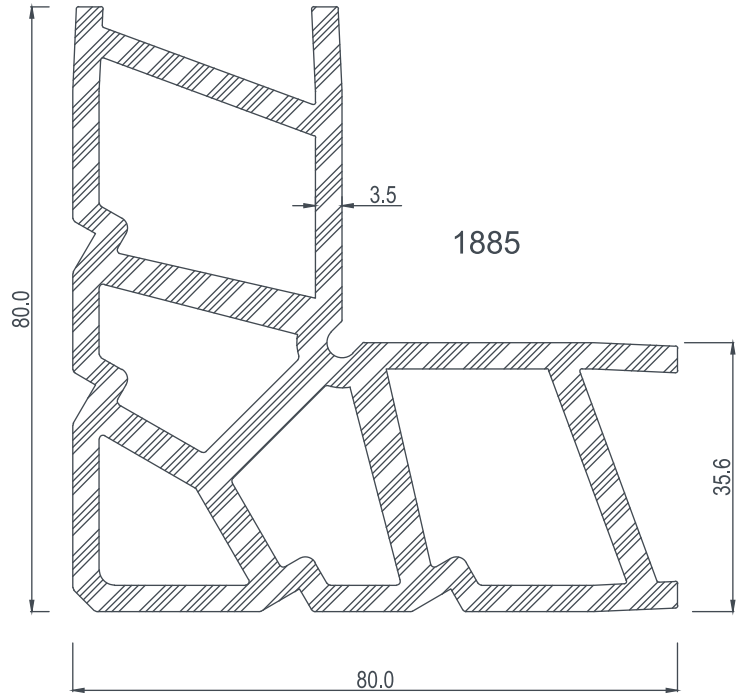
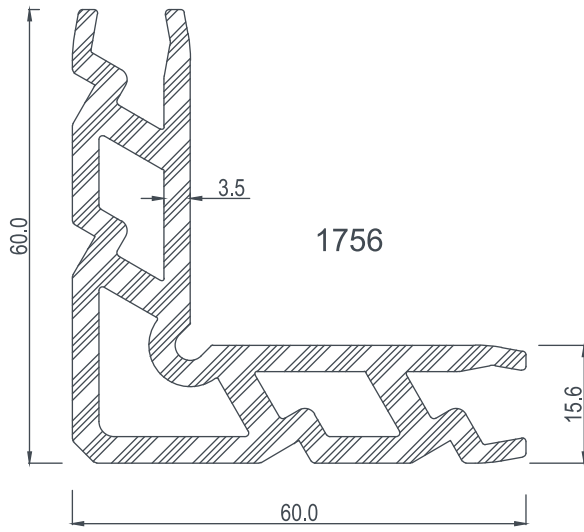

KÖŞE TAKOZLARI / Corner Cleats

Nr	 L m	AKS. KODU Acs. Code	KESİM ÖLÇÜSÜ Cutting Size
5340	1756	1756-26,8	26,8 mm
	1756	1756-5,4	5,4 mm
5353	1756	1756-25,4	25,4 mm
	1885	1885-18,3	18,3 mm
5577	1885	1885-5,3	5,3 mm
	4550	4550-18,3	18,3 mm
5714	4550	4550-5,3	5,3 mm



E 55

PROFİLLER / PROFILES

COD Code	AGIRLIK (kg/m) Weight	Jxx cm4	Jyy cm4	Wxx cm3	Wyy cm3	L m
5127	3,484	----	---	----	---	6

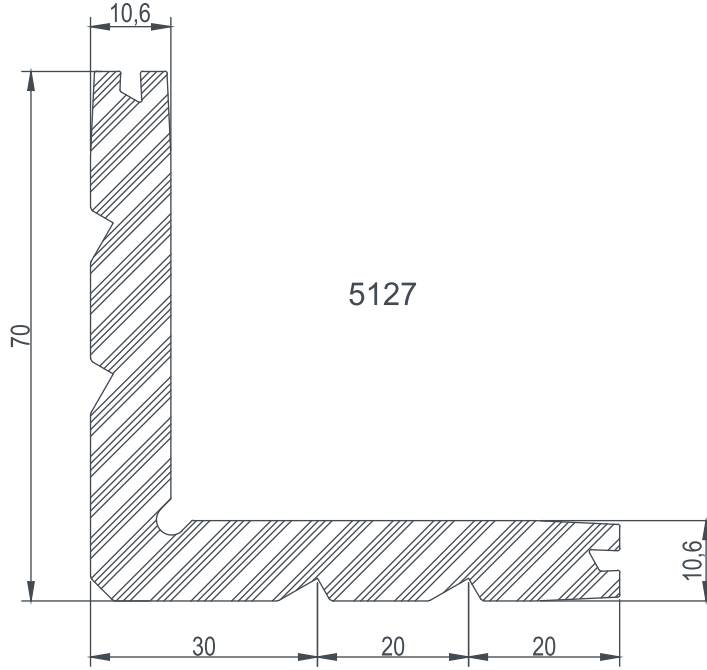

KÖŞE TAKOZLARI / Corner Cleats

Nr	L m	AKS. KODU Acs. Code	KESİM ÖLÇÜSÜ Cutting Size
5300	5127	5127-21,3	21,3 mm
	5127	5127-10,5	10,5 mm
5303	5127	5127-18,6	18,6 mm
	5127	5127- 5,3	5,3 mm
5307	5127	5127-21,3	21,3 mm
	5127	5127-10,5	10,5 mm
5317	5127	5127-21,3	21,3 mm
	5127	5127-10,5	10,5 mm
5320	5127	5127-18,6	18,6 mm
	5127	5127- 5,3	5,3 mm
5324	5127	5127-21,3	21,3 mm
	5127	5127-10,5	10,5 mm
5335	5127	5127-18,77	18,77 mm
	5127	5127-18,77	18,77 mm



E 55

PROFİLLER / PROFILES

COD Code	AGIRLIK (kg/m) Weight	Jxx cm ⁴	Jyy cm ⁴	Wxx cm ³	Wyy cm ³	L m
5128	3,652	----	----	---	---	6

KÖŞE TAKOZLARI / Corner Cleats

Nr	L m	AKS. KODU Ac. Code	KESİM ÖLÇÜSÜ Cutting Size
5301	5128	5128-21,3	21,3 mm
	5128	5128-10,5	10,5 mm
5304	5128	5128-18,6	18,6 mm
	5128	5128-5,3	5,3 mm
5308	5128	5128-21,3	21,3 mm
	5128	5128-10,5	10,5 mm
5311	5128	5128-21,3	21,3 mm
	5128	5128-10,5	10,5 mm
5312	5128	5128-21,3	21,3 mm
	5128	5128-10,5	10,5 mm
5318	5128	5128-21,3	21,3 mm
	5128	5128-10,5	10,5 mm
5321	5128	5128-18,6	18,6 mm
	5128	5128-5,3	5,3 mm
5325	5128	5128-21,3	21,3 mm
	5128	5128-10,5	10,5 mm
5328	5128	5128-21,3	21,3 mm
	5128	5128-10,5	10,5 mm
5329	5128	5128-21,3	21,3 mm
	5128	5128-10,5	10,5 mm
5333	5128	5128-18,3	18,3 mm
	5128	5128-5,4	5,4 mm
5725	5128	5128-21,3	21,3 mm
	5128	5128-10,5	10,5 mm
5434	5128	5128-21,3	21,3 mm
	5128	5128-10,5	10,5 mm
5711	5128	5128-18,6	18,6 mm
	5128	5128-5,3	5,3 mm
5713	5128	5128-21,3	21,3 mm
	5128	5128-10,5	10,5 mm
5350	5128	5128-21,3	21,3 mm
	5128	5128-10,5	10,5 mm
5351	5128	5128-21,3	21,3 mm
	5128	5128-10,5	10,5 mm
5352	5128	5128-21,3	21,3 mm
	5128	5128-10,5	10,5 mm

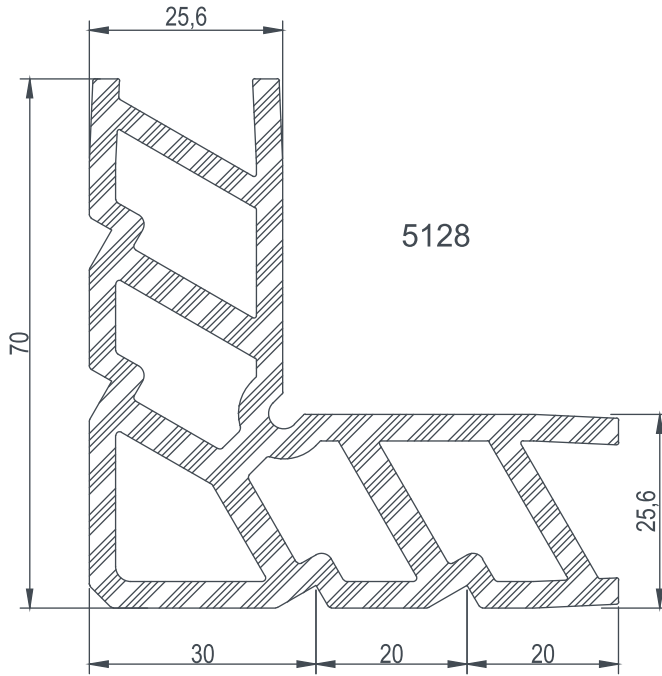



E 55

PROFİLLER / PROFILES

COD Code	AGIRLIK (kg/m) Weight	Jxx cm ⁴	Jyy cm ⁴	Wxx cm ³	Wyy cm ³	L m
5129	4,618	---	---	---	---	6

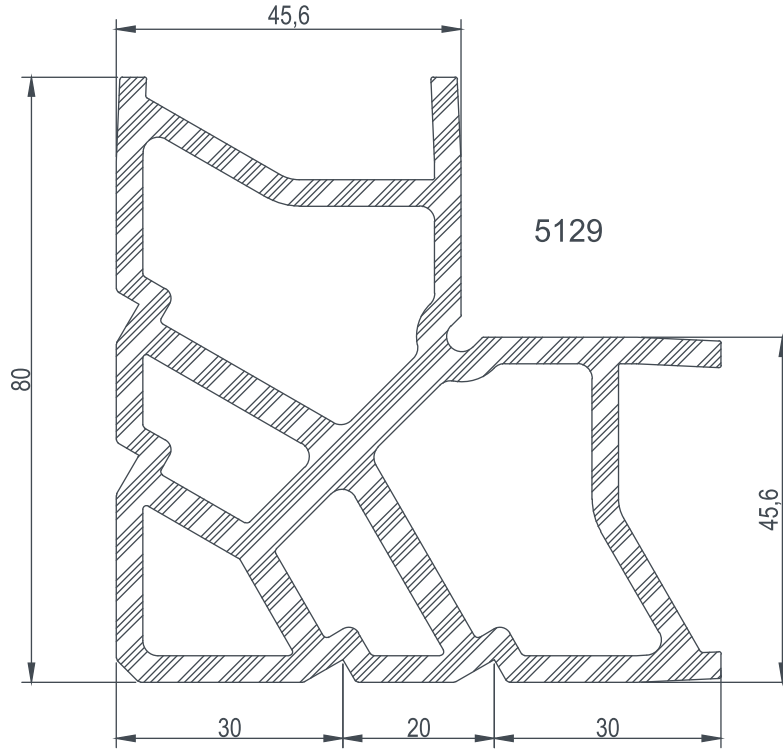

KÖŞE TAKOZLARI / Corner Cleats

Nr	 L m	AKS. KODU Acs. Code	KESİM ÖLÇÜSÜ Cutting Size
5302	5129	5129-21,3	21,3 mm
	5129	5129-10,5	10,5 mm
5306	5129	5129-26,7	26,7 mm
	5129	5129-5,3	5,3 mm
5309	5129	5129-21,3	21,3 mm
	5129	5129-10,5	10,5 mm
5319	5129	5129-21,3	21,3 mm
	5129	5129-10,5	10,5 mm
5323	5129	5129-26,7	26,7 mm
	5129	5129-5,3	5,3 mm
5326	5129	5129-21,3	21,3 mm
	5129	5129-10,5	10,5 mm
5334	5129	5129-18,3	18,3 mm
	5129	5129-5,4	5,4 mm
5433	5129	5129-21,3	21,3 mm
	5129	5129-10,5	10,5 mm



E 55

PROFİLLER / PROFILES

COD Code	AGIRLIK (kg/m) Weight	Jxx cm ⁴	Jyy cm ⁴	Wxx cm ³	Wyy cm ³	L m
4542	5,381	---	---	---	---	6

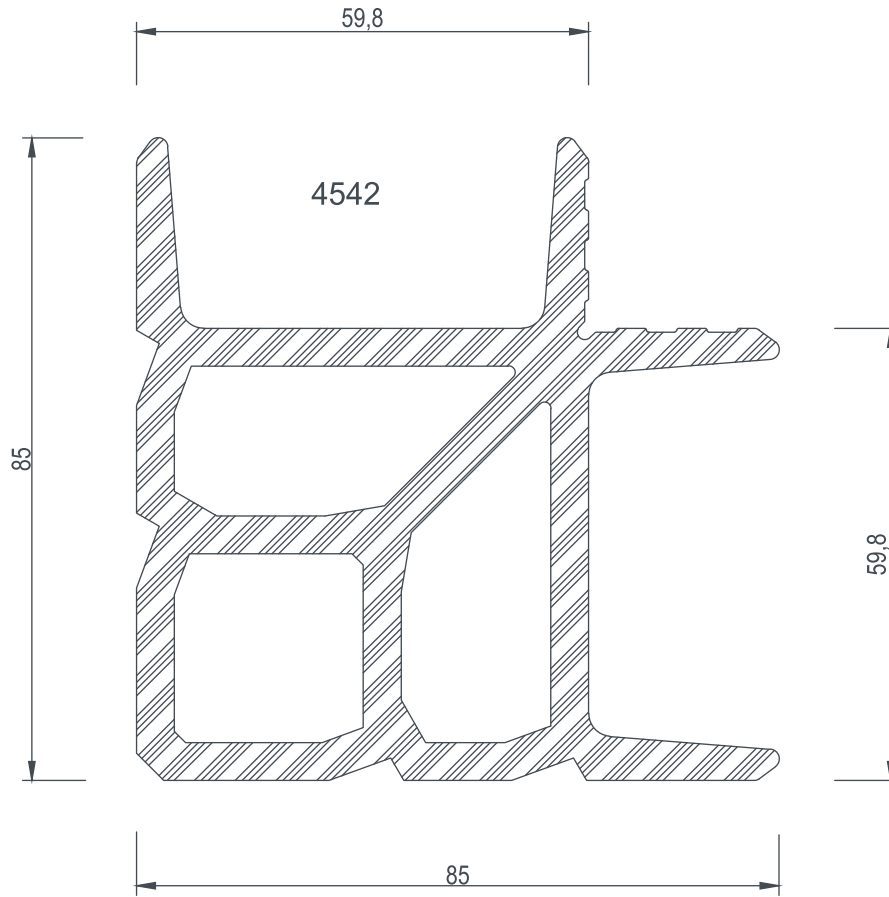

KÖŞE TAKOZLARI / Corner Cleats

Nr	 L m	AKS. KODU Acs. Code	KESİM ÖLÇÜSÜ Cutting Size
5564	4542	4542-18,6	18,6 mm
	4542	4542- 5,3	5,3 mm
5567	4542	4542-18,6	18,6 mm
	4542	4542- 5,3	5,3 mm
5712	4542	4542-18,6	18,6 mm
	4542	4542- 5,3	5,3 mm



E 55

PROFİLLER / PROFILES

COD Code	AGIRLIK (kg/m) Weight	Jxx cm ⁴	Jyy cm ⁴	Wxx cm ³	Wyy cm ³	L m
5569	0,555	---	---	---	---	6
5570	0,393	---	---	---	---	6
5571	0,772	---	---	---	---	6

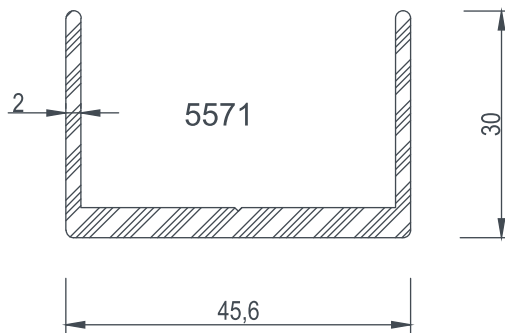
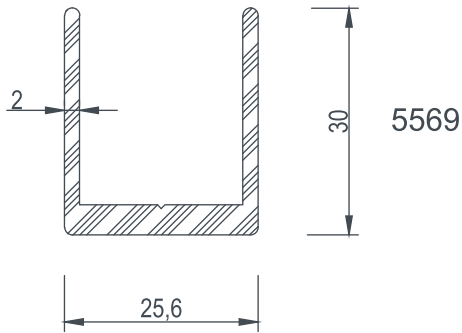
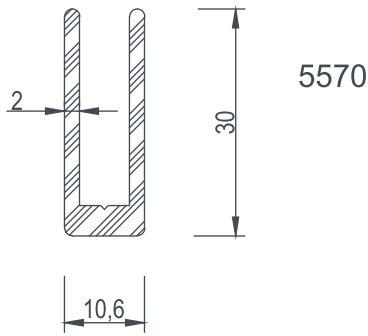

ORTA KAYIT BAĞLANTI / Mullion Connection Piece

Nr	 L m	 AKS. KODU Acs. Code	KESİM ÖLÇÜSÜ Cutting Size
5307	5570	5570-21,3	21,3 mm
5308	5569	5569-21,3	21,3 mm
5309	5571	5571-46,6	45,6 mm
5310	----	----	---
5311	5569	5569-21,3	21,3 mm
5312	5569	5569-21,3	21,3 mm
5313	5569	5569-21,3	21,3 mm
5324	5570	5570-21,3	21,3 mm
5325	5569	5569-21,3	21,3 mm
5326	5571	5571-45,6	45,6 mm
5327	----	----	---
5328	5569	5569-21,3	21,3 mm
5329	5569	5569-21,3	21,3 mm
5330	5569	5569-21,3	21,3 mm
5713	5569	5569-21,3	21,3 mm
5710	5569	5569-21,3	21,3 mm



clarks

E 55

DETAYLAR
DETAILS







E 55

DETAYLAR / DETAILS

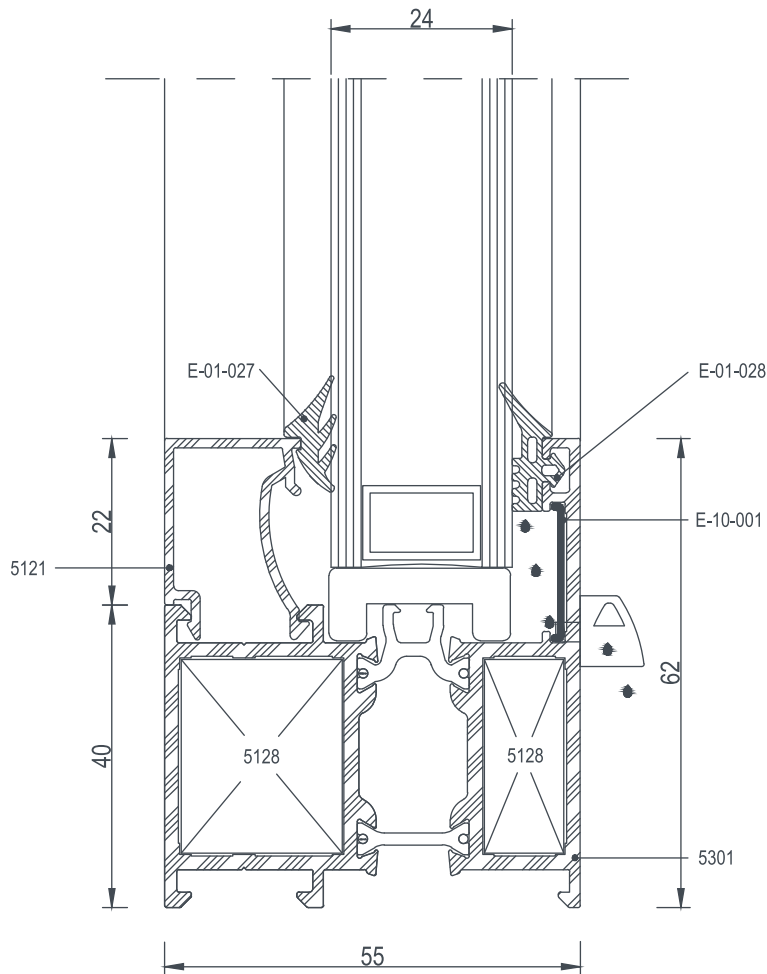
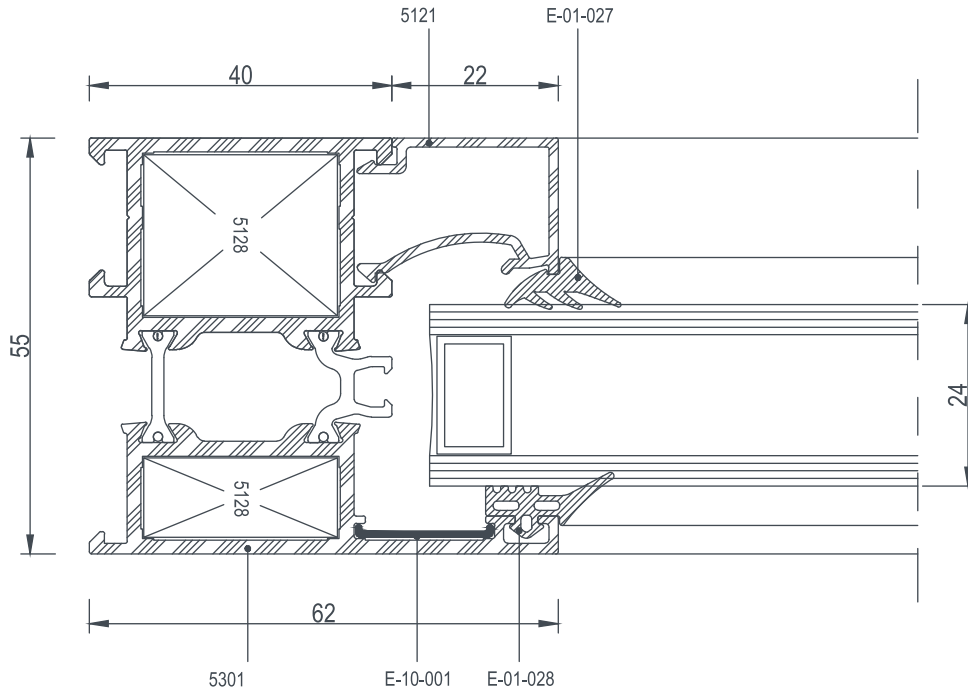

53





E 55

DETAYLAR / DETAILS

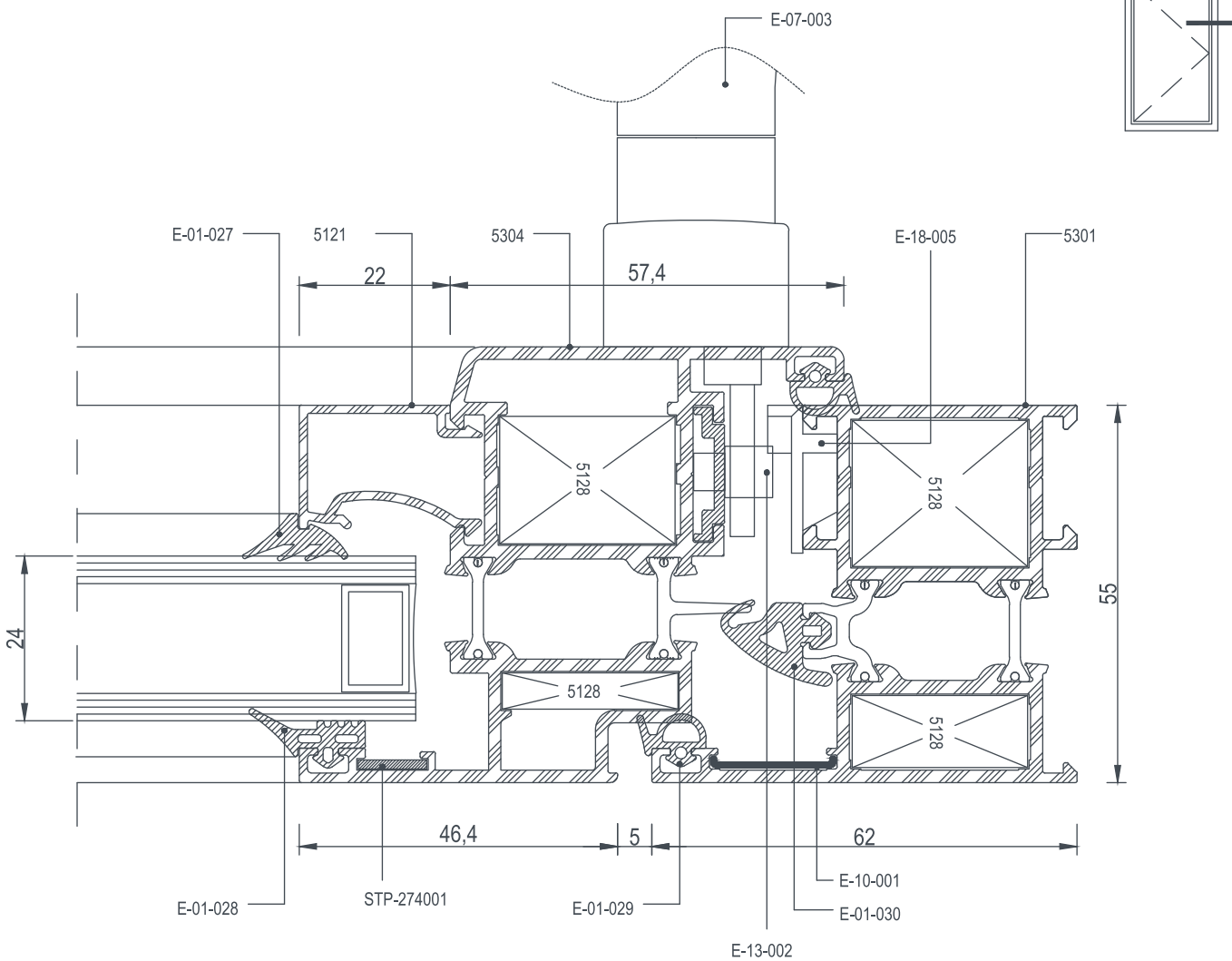
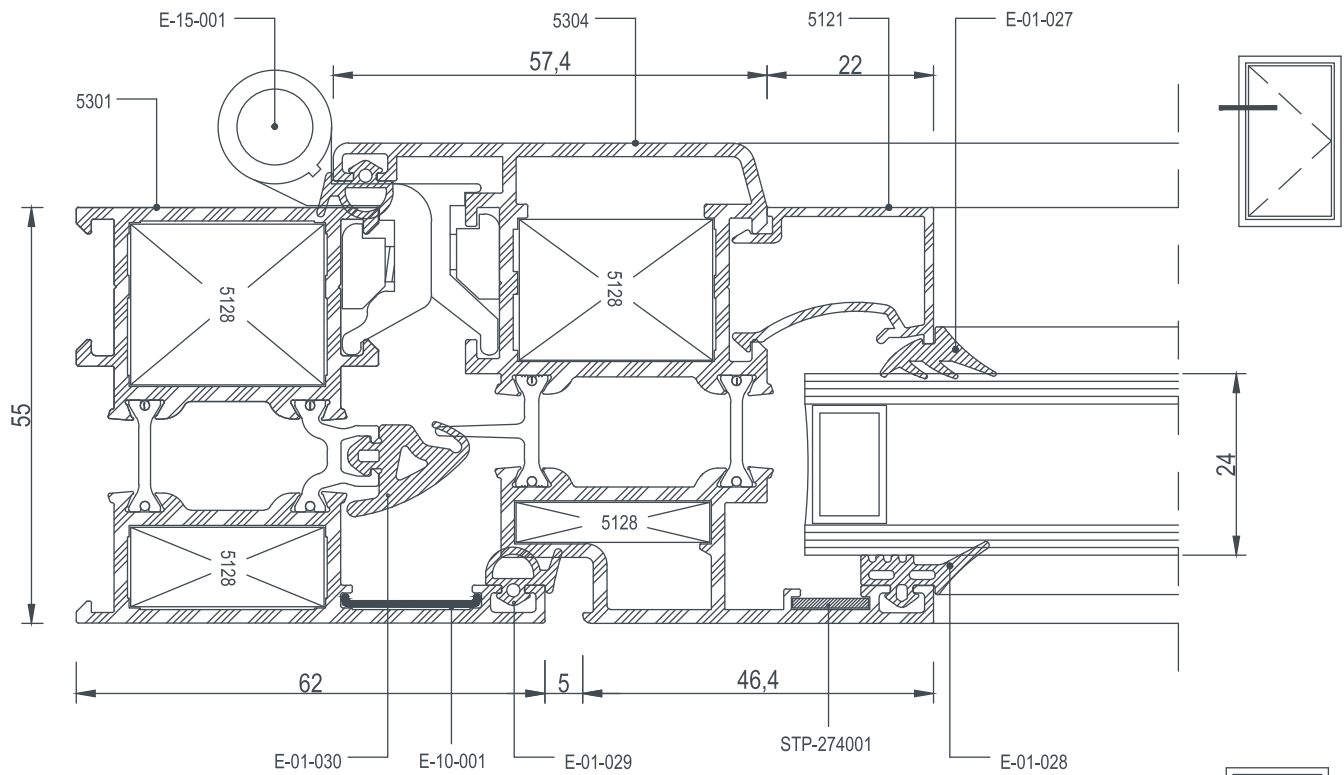



E 55

DETAYLAR / DETAILS

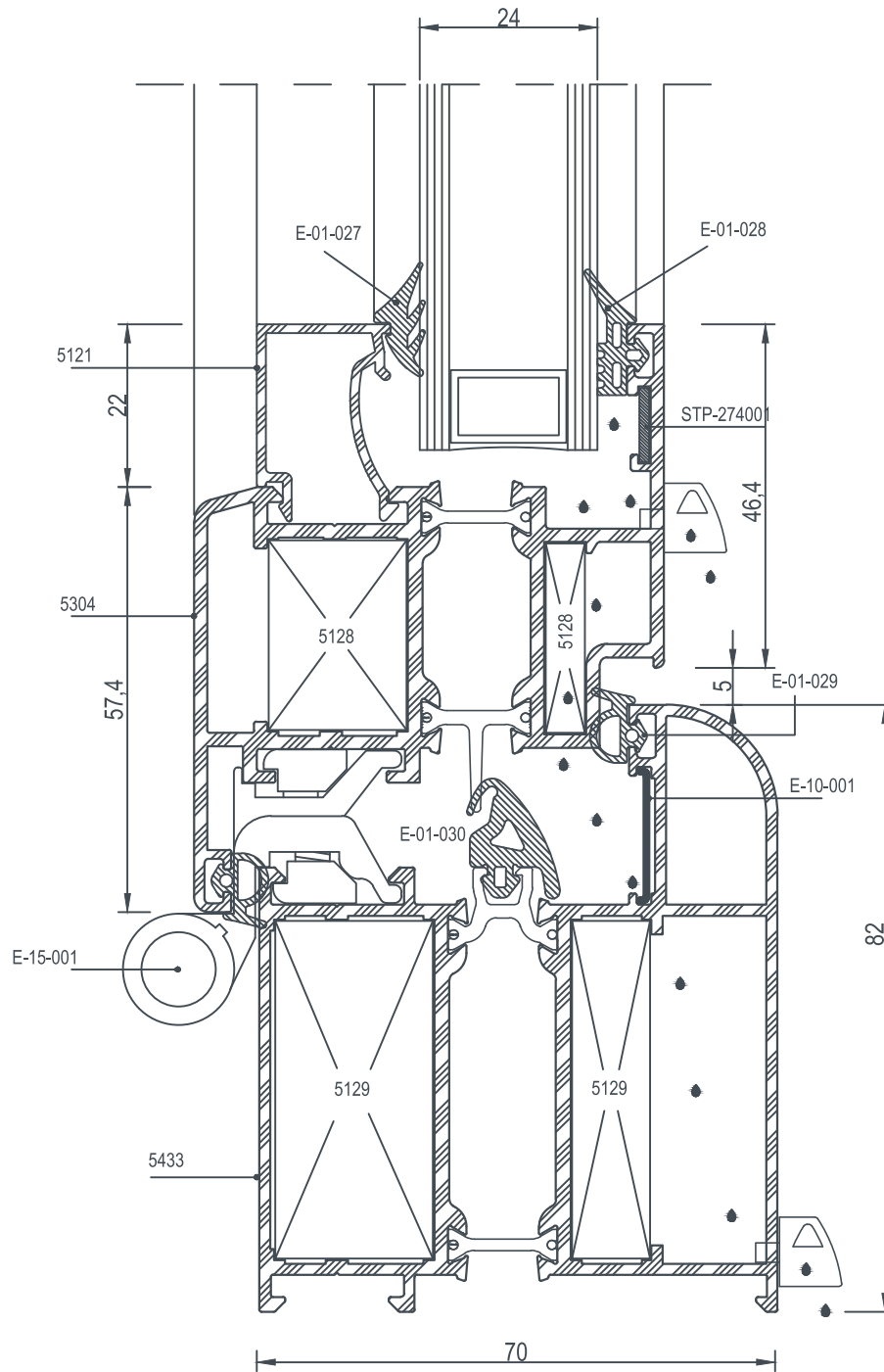
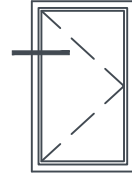



E 55

DETAYLAR / DETAILS

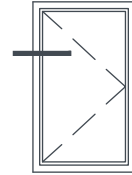
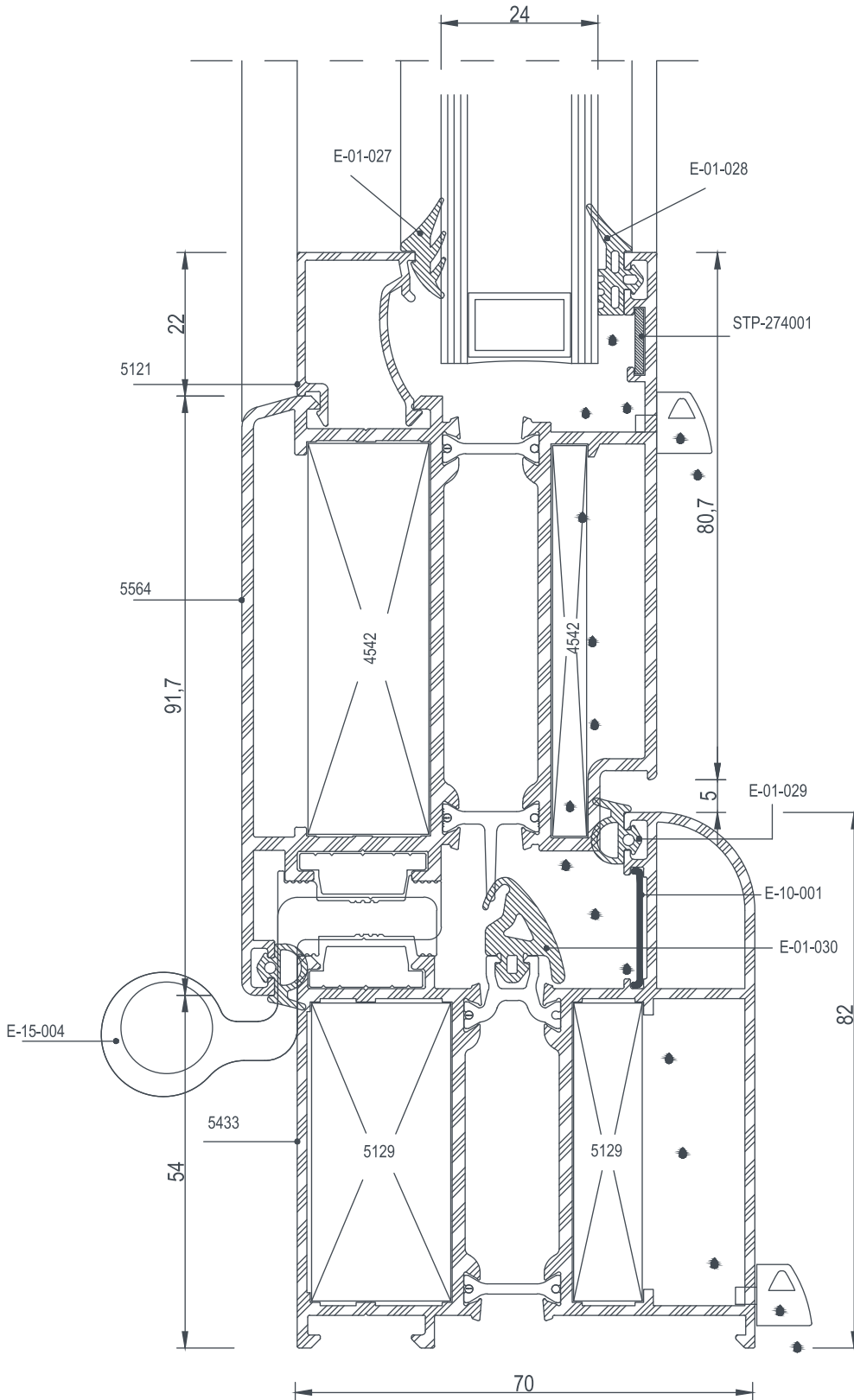



E 55

DETAYLAR / DETAILS

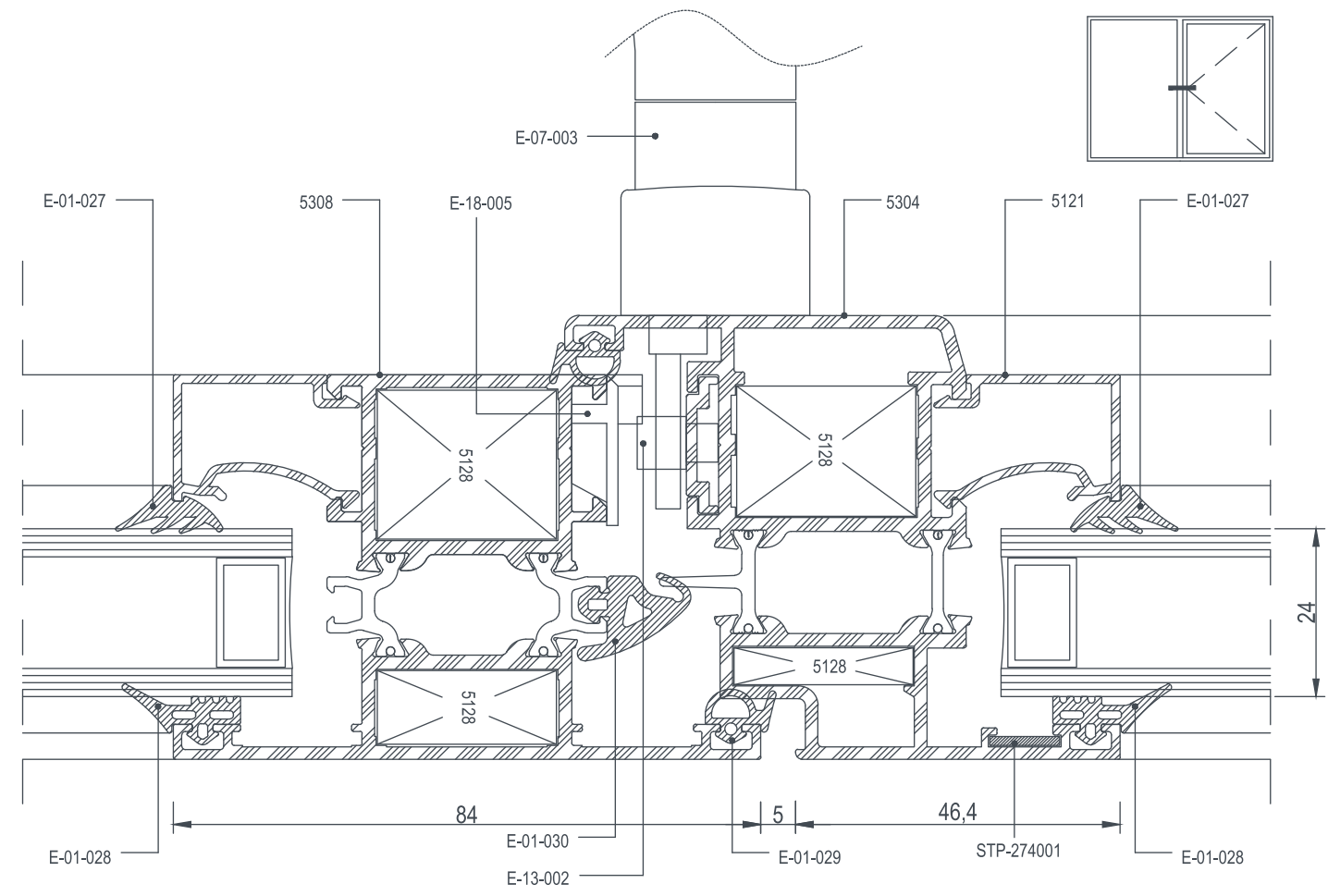
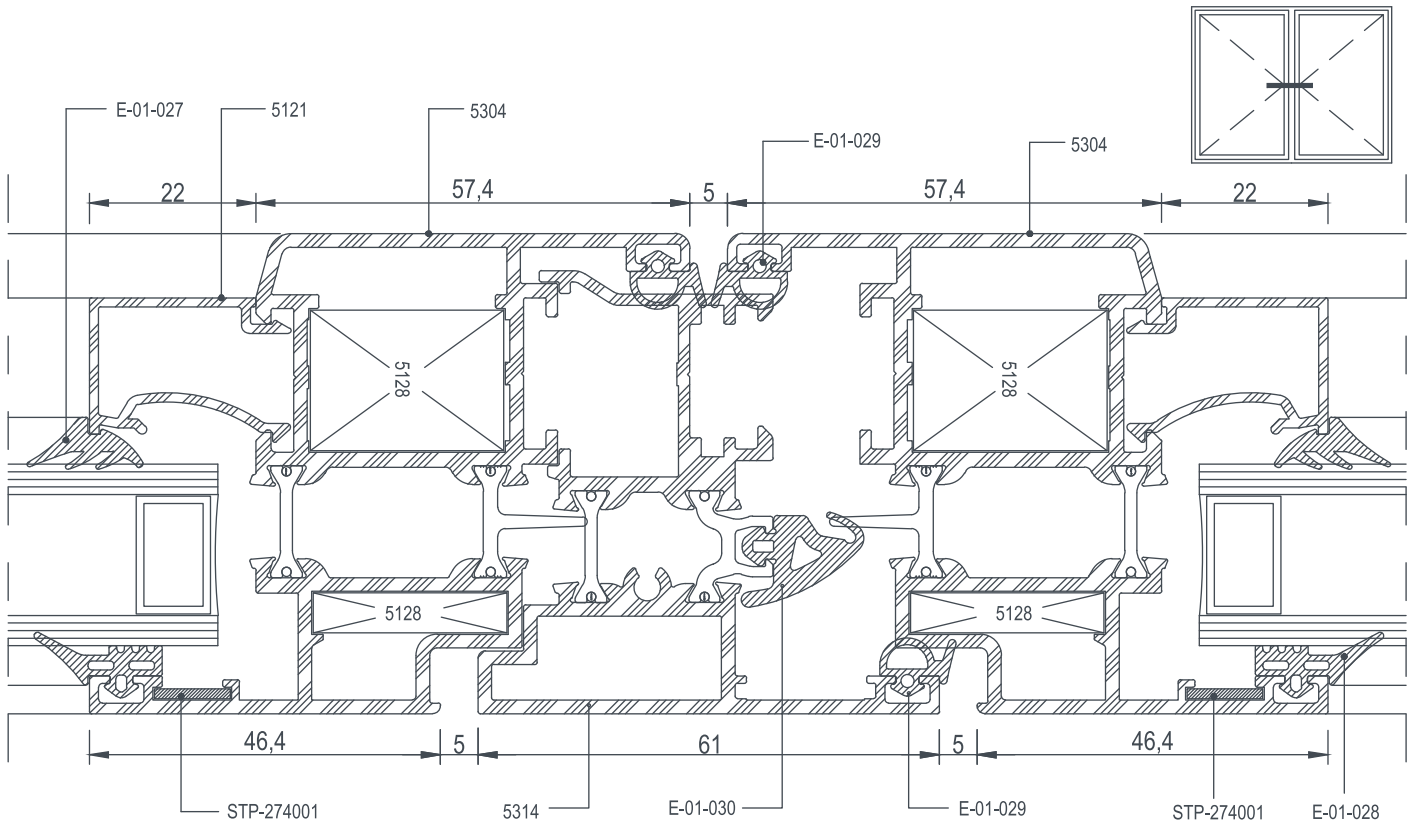



E 55

DETAYLAR / DETAILS

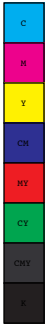
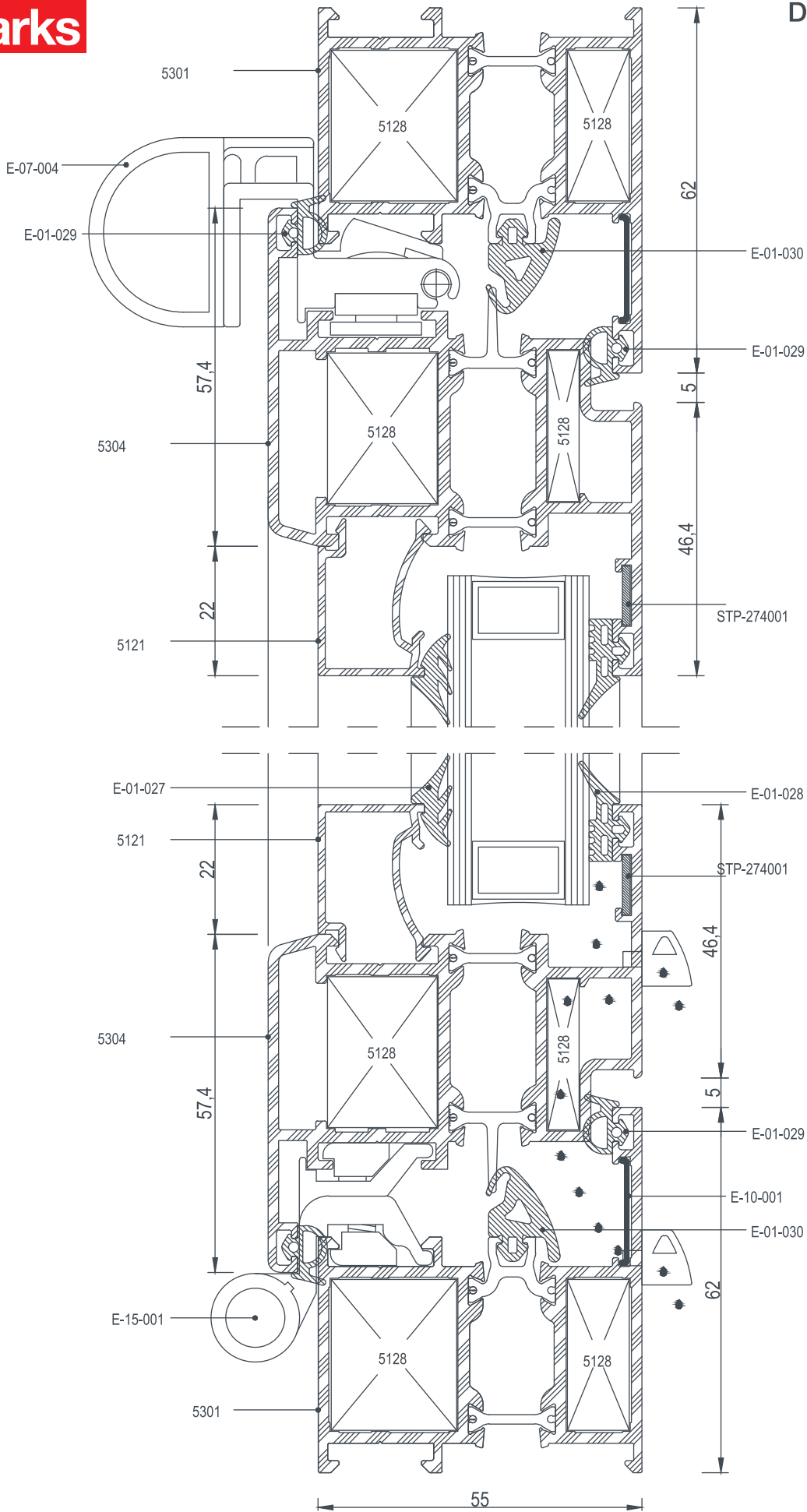



E 55

DETAYLAR / DETAILS

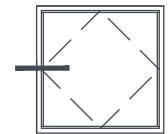
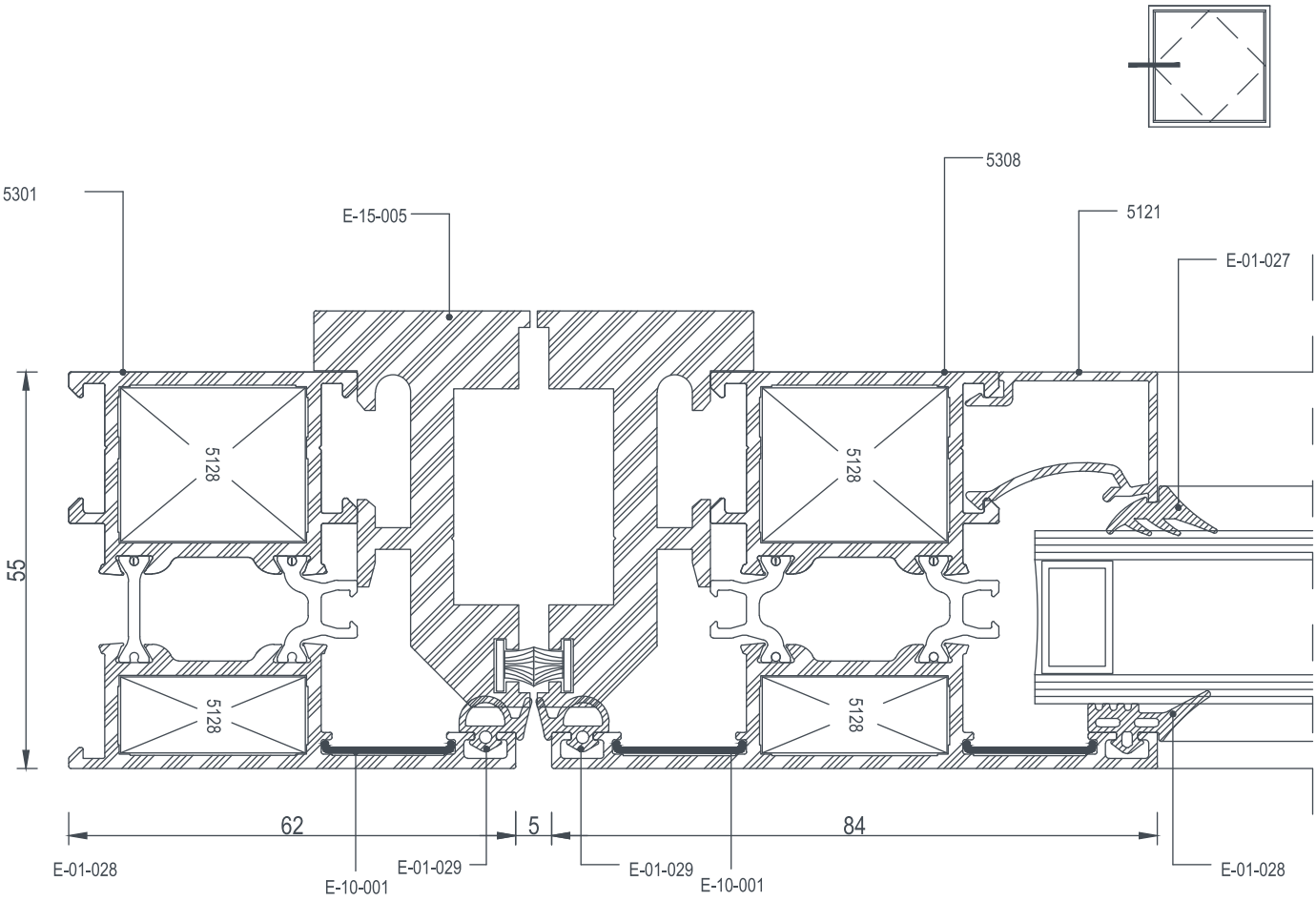
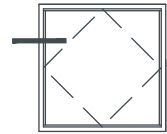
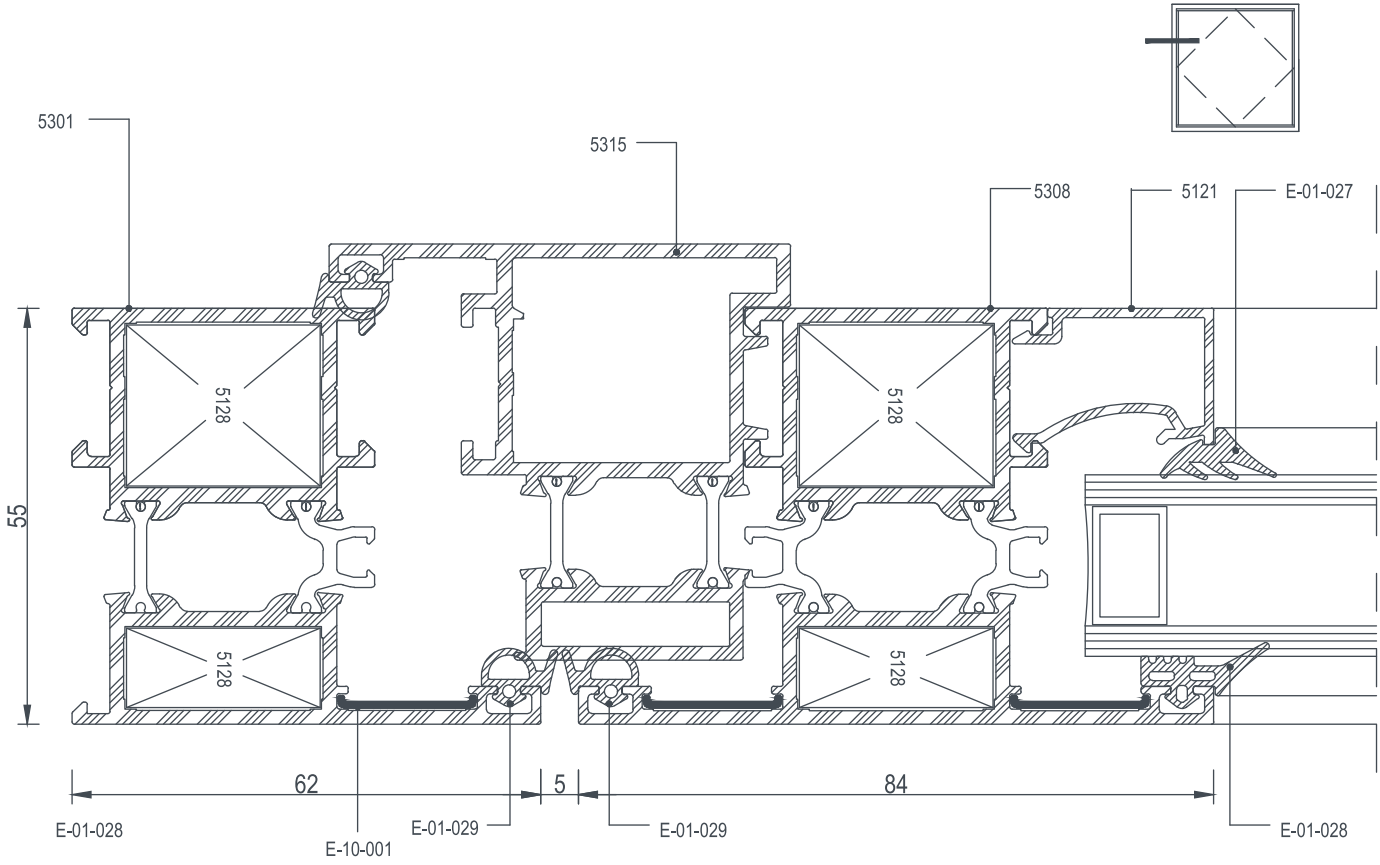



E 55

DETAYLAR / DETAILS

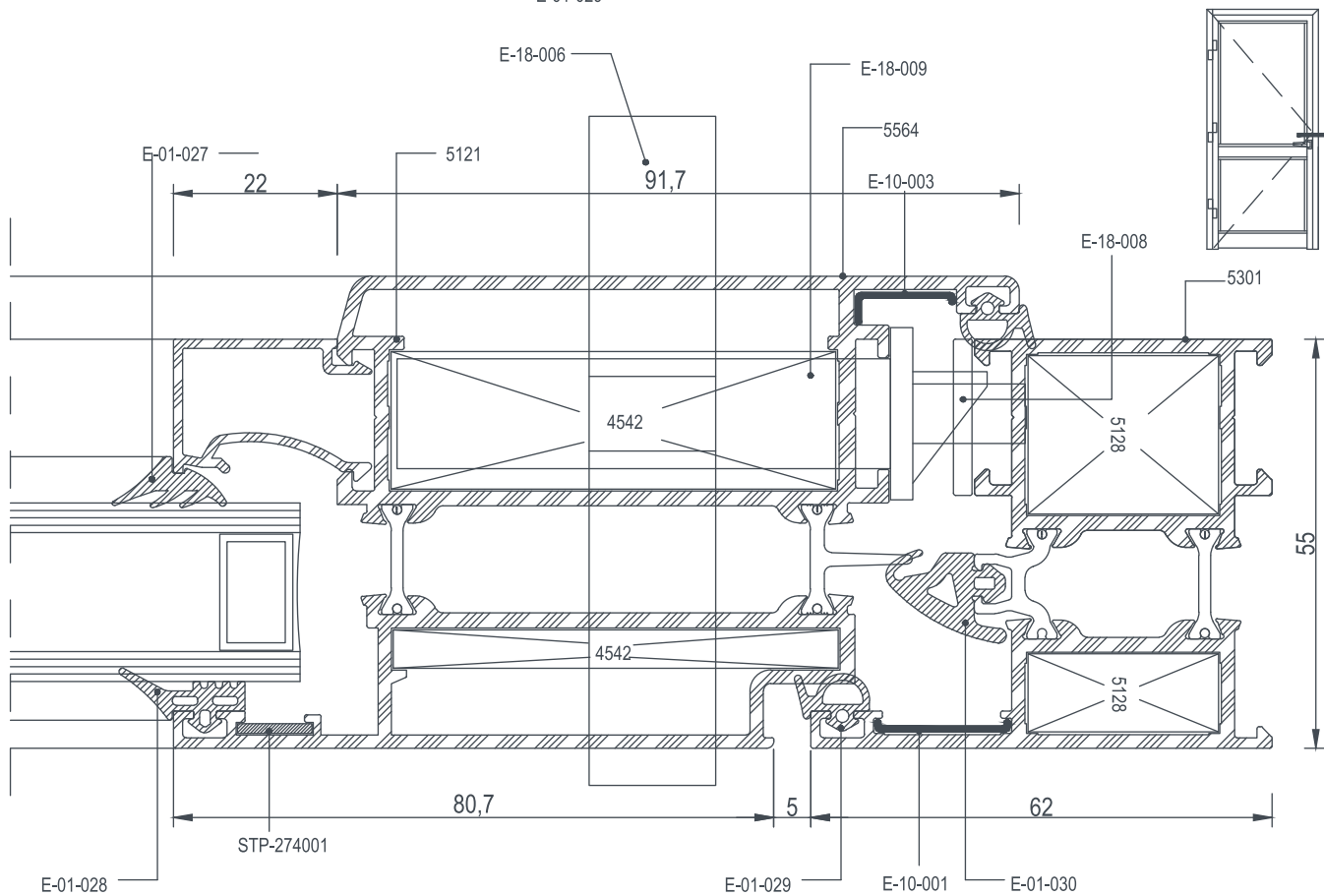
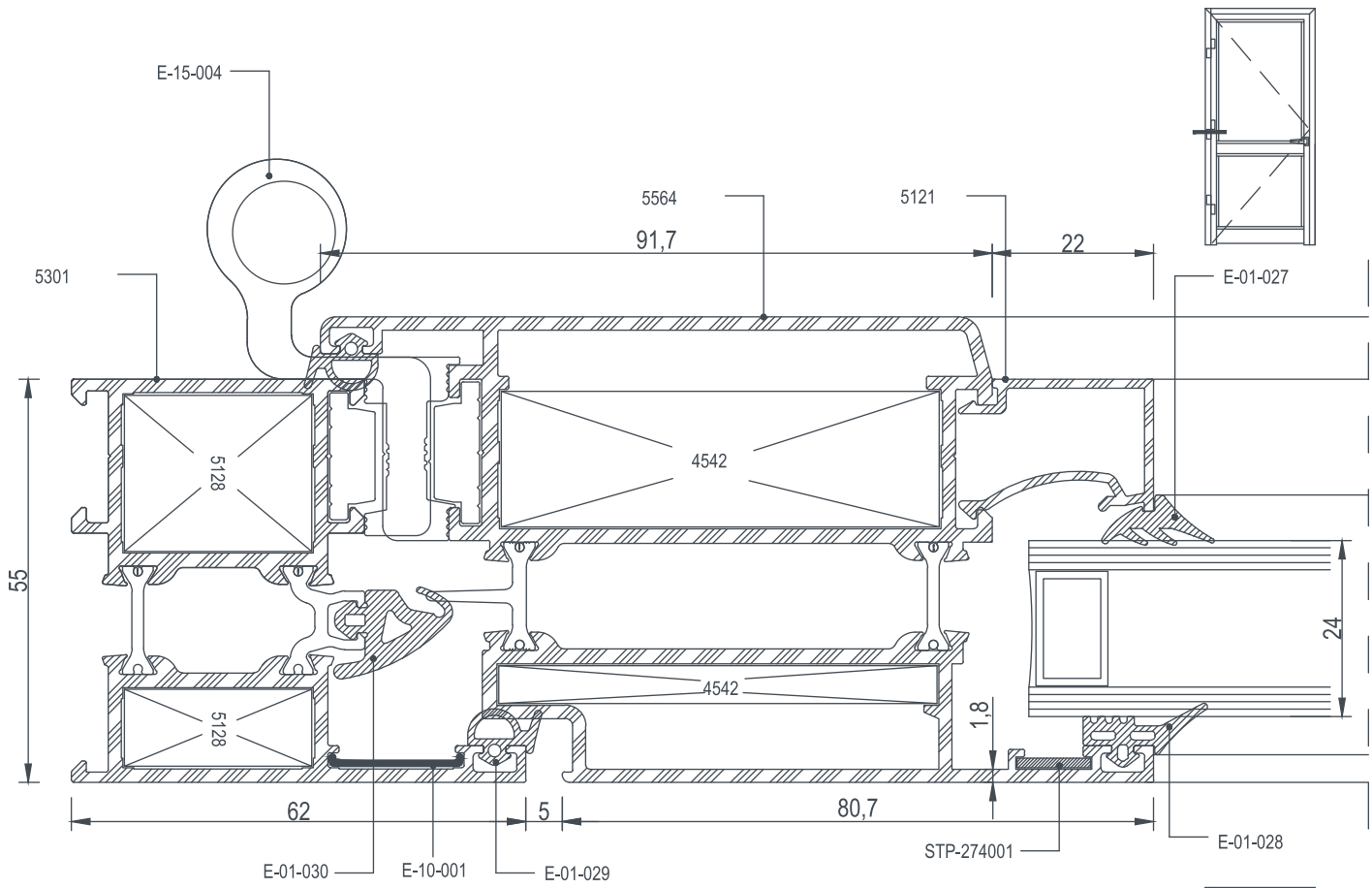



E 55

DETAYLAR / DETAILS

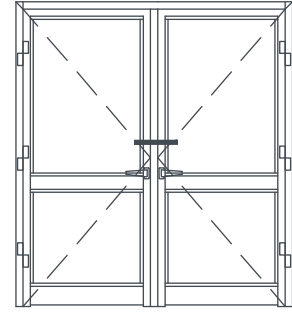
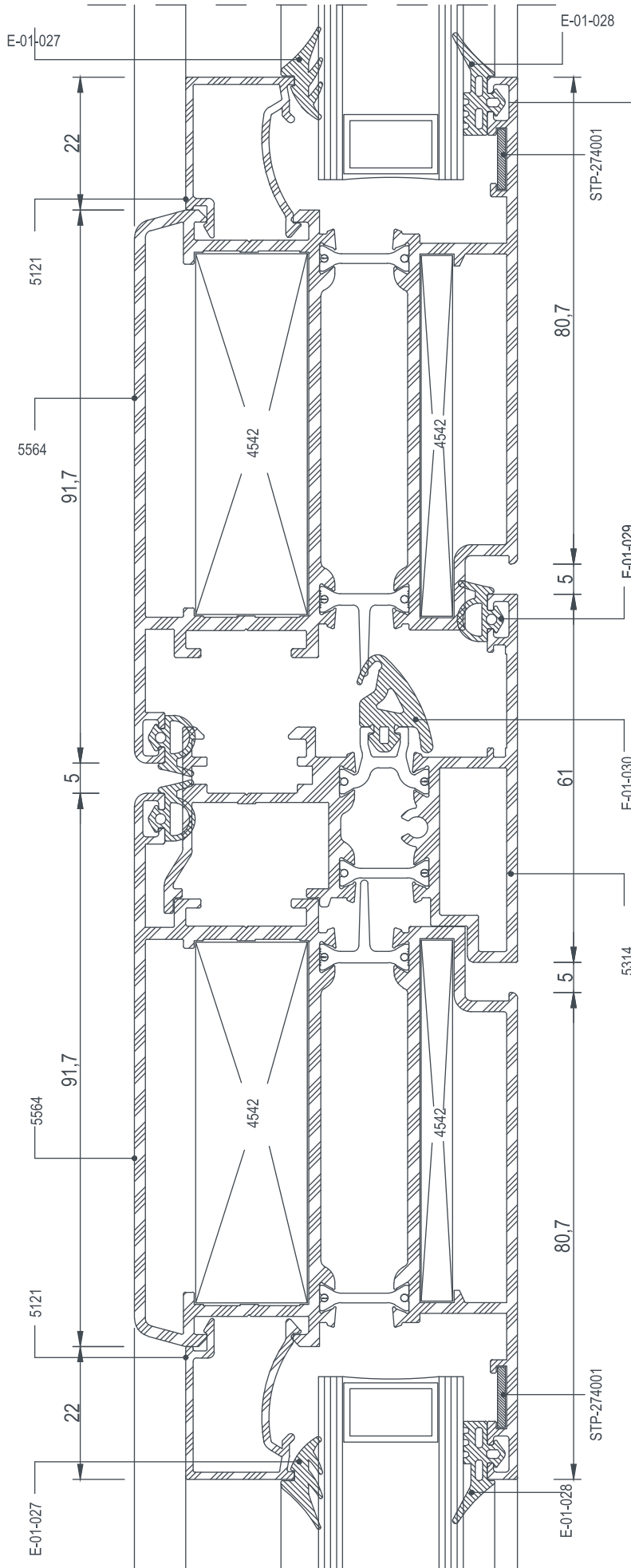



E 55

DEAYLAR / DETAILS

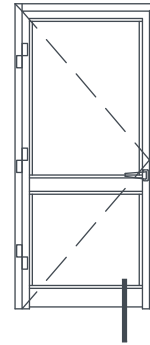
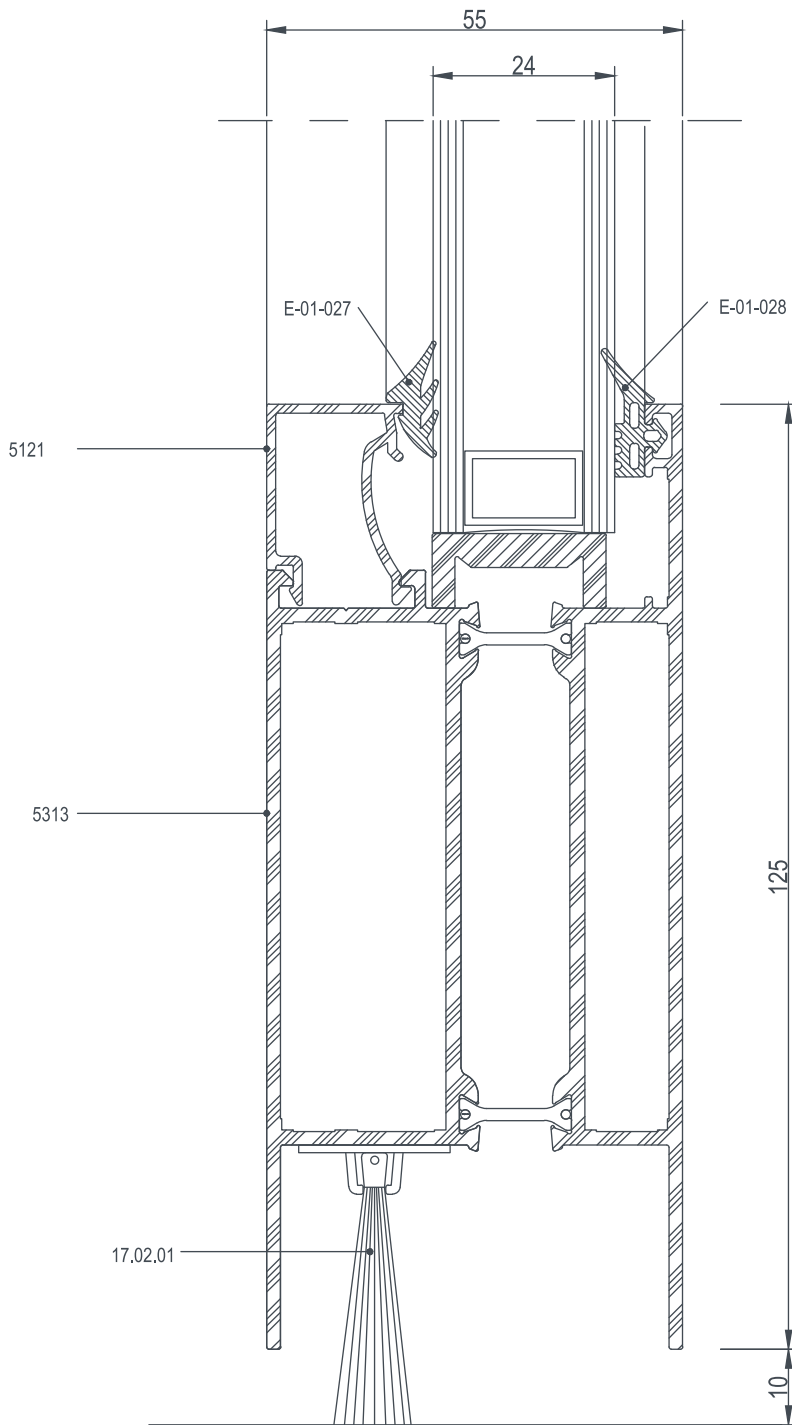



E 55

DETAYLAR / DETAILS

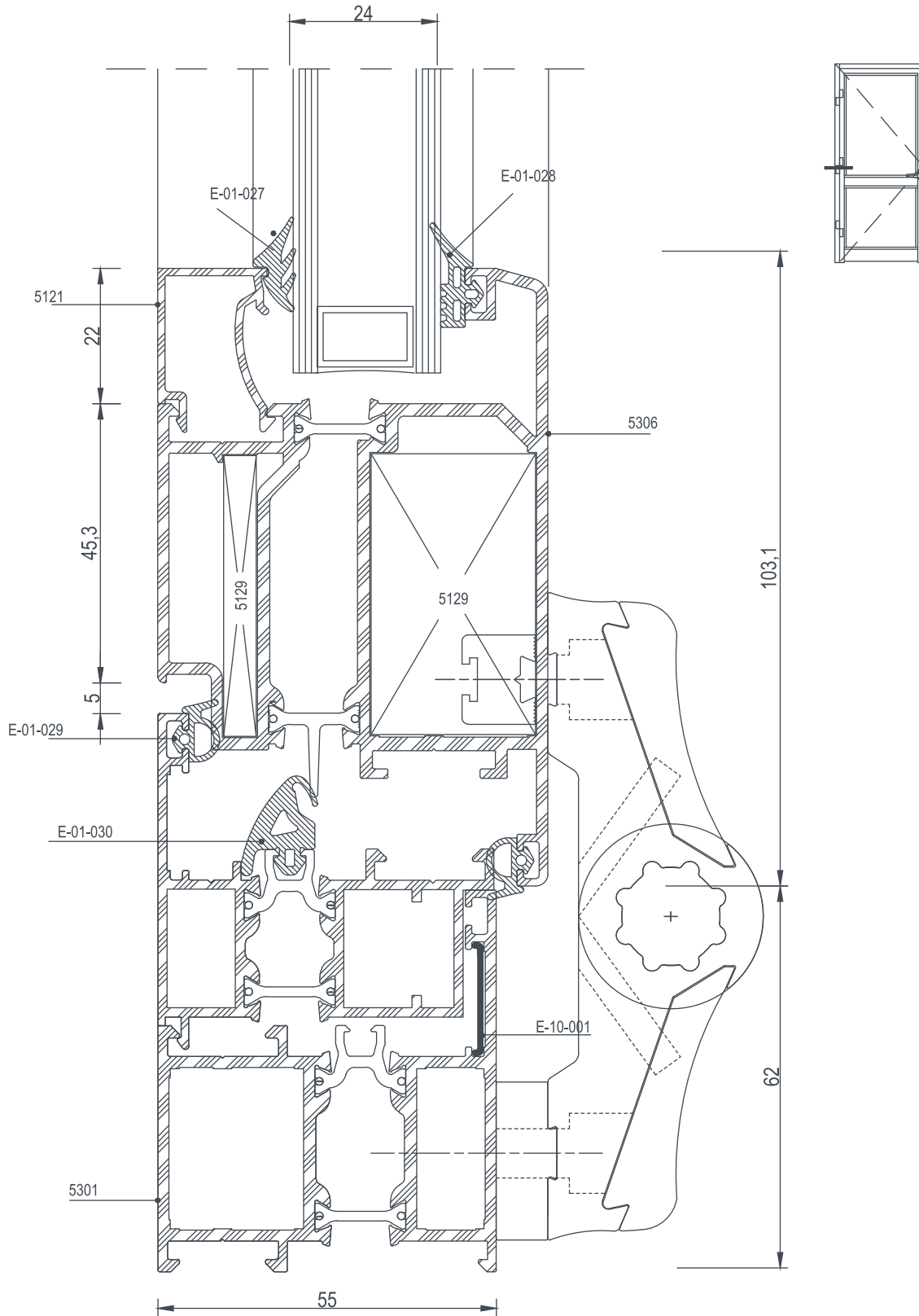



E 55

DETAYLAR / DETAILS

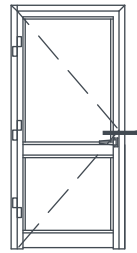
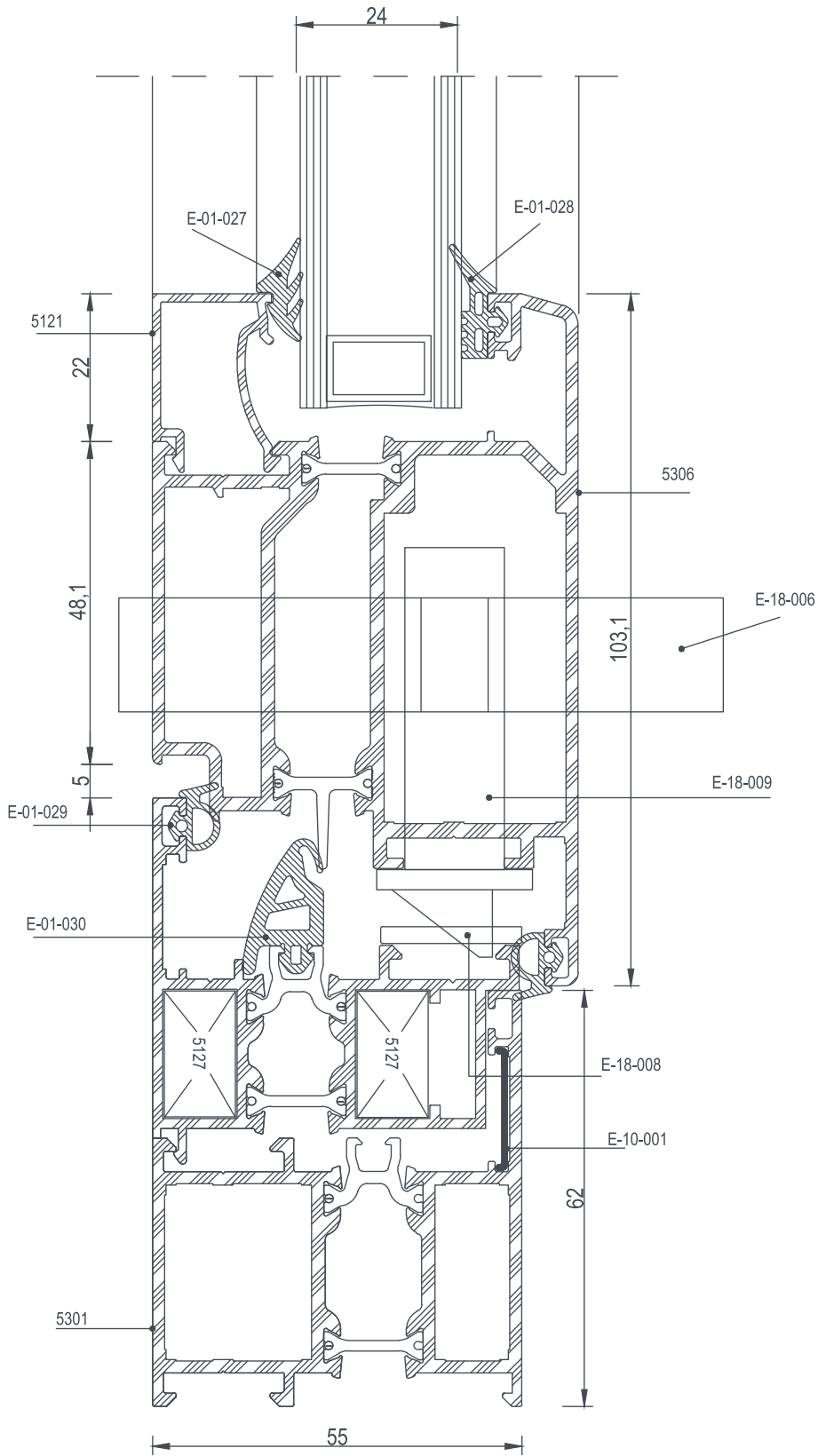



E 55

DETAYLAR / DETAILS

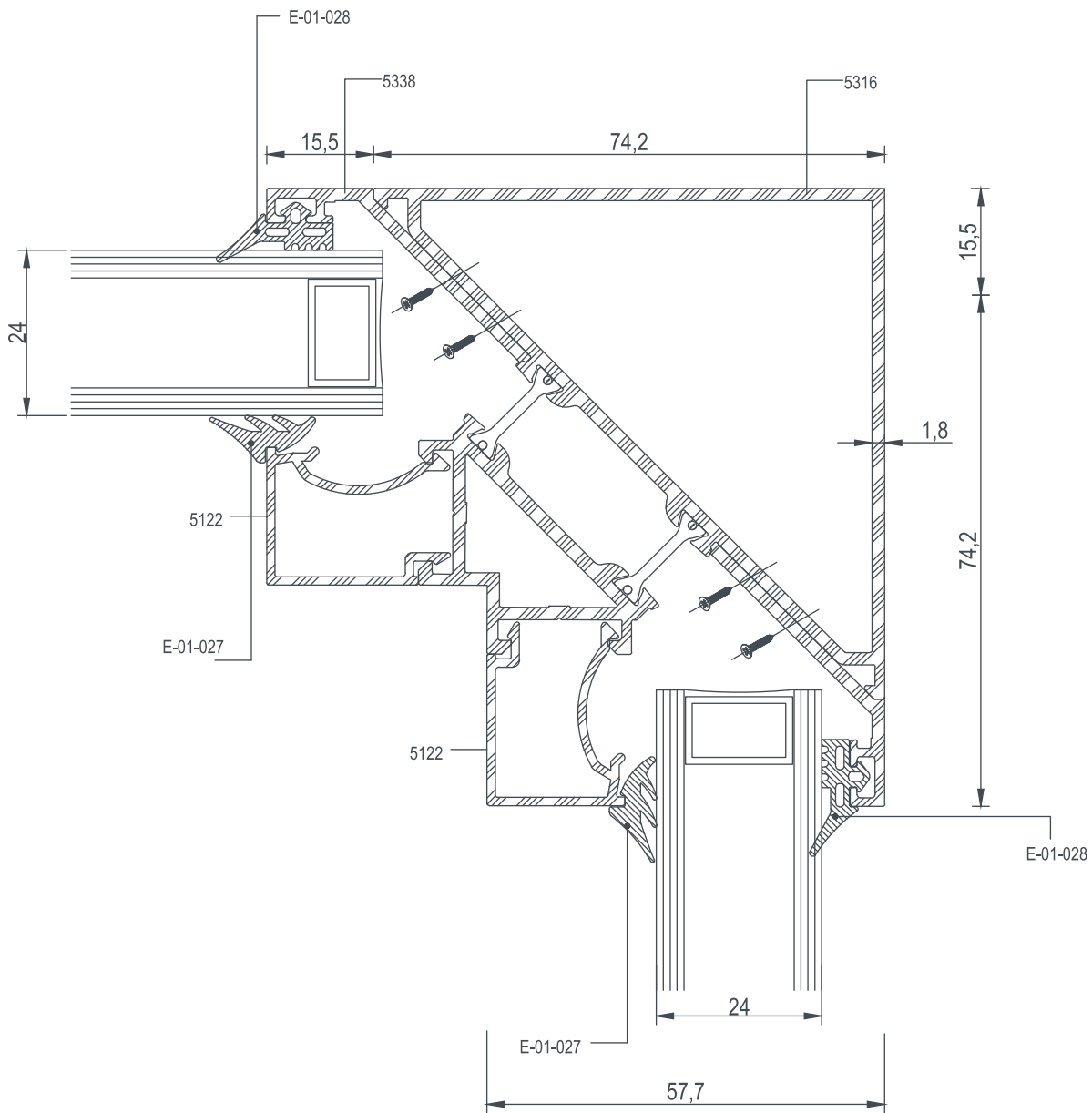
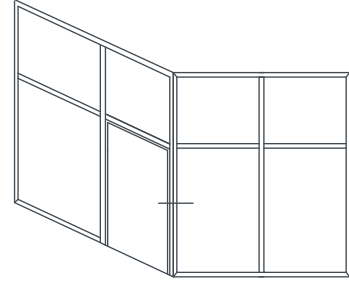



E 55

DETAYLAR / DETAILS

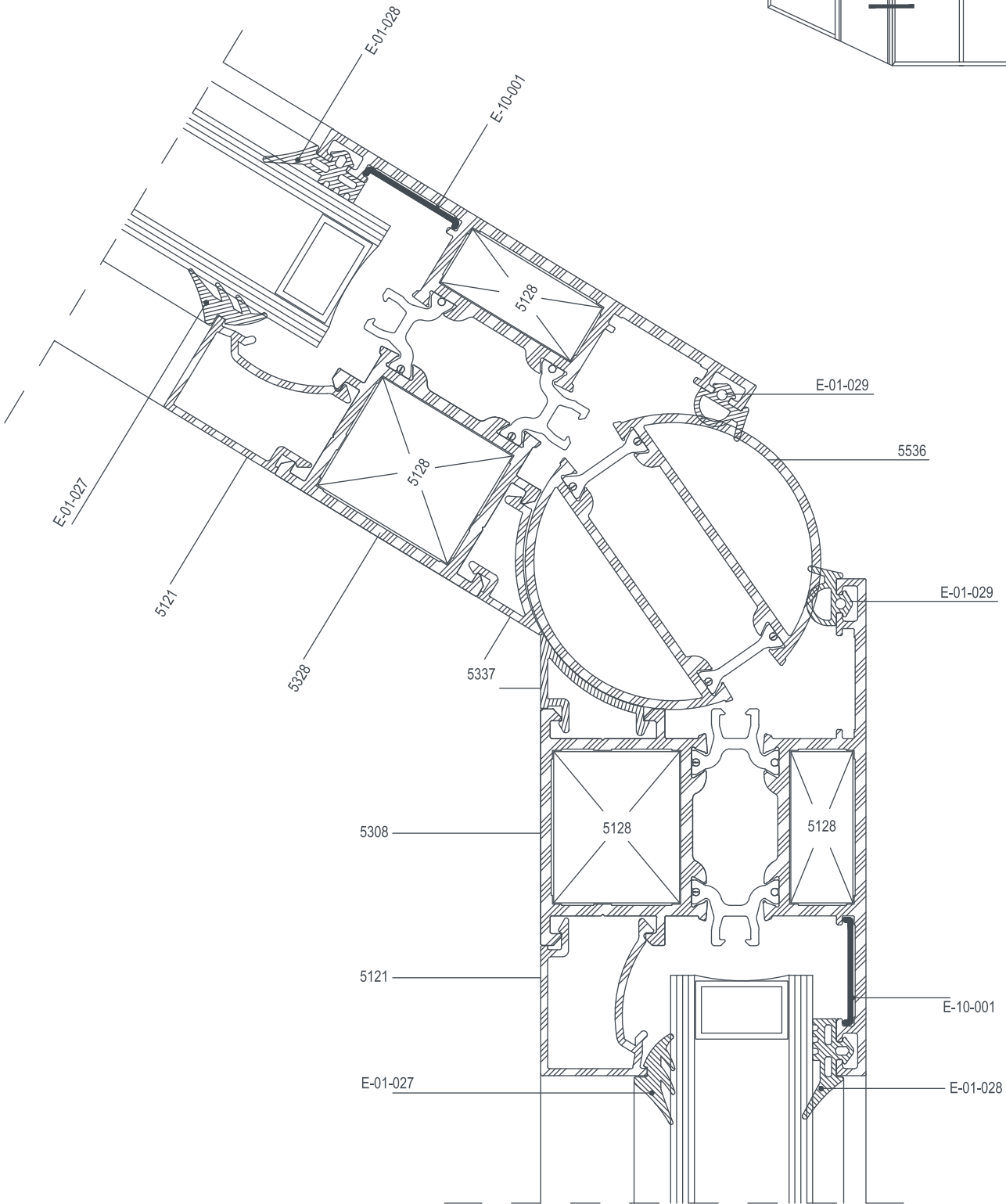
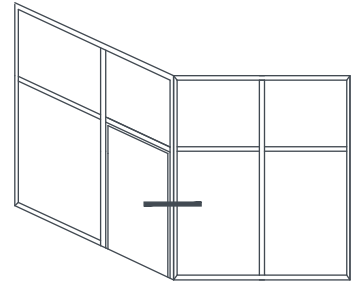



E 55

DETAYLAR / DETAILS

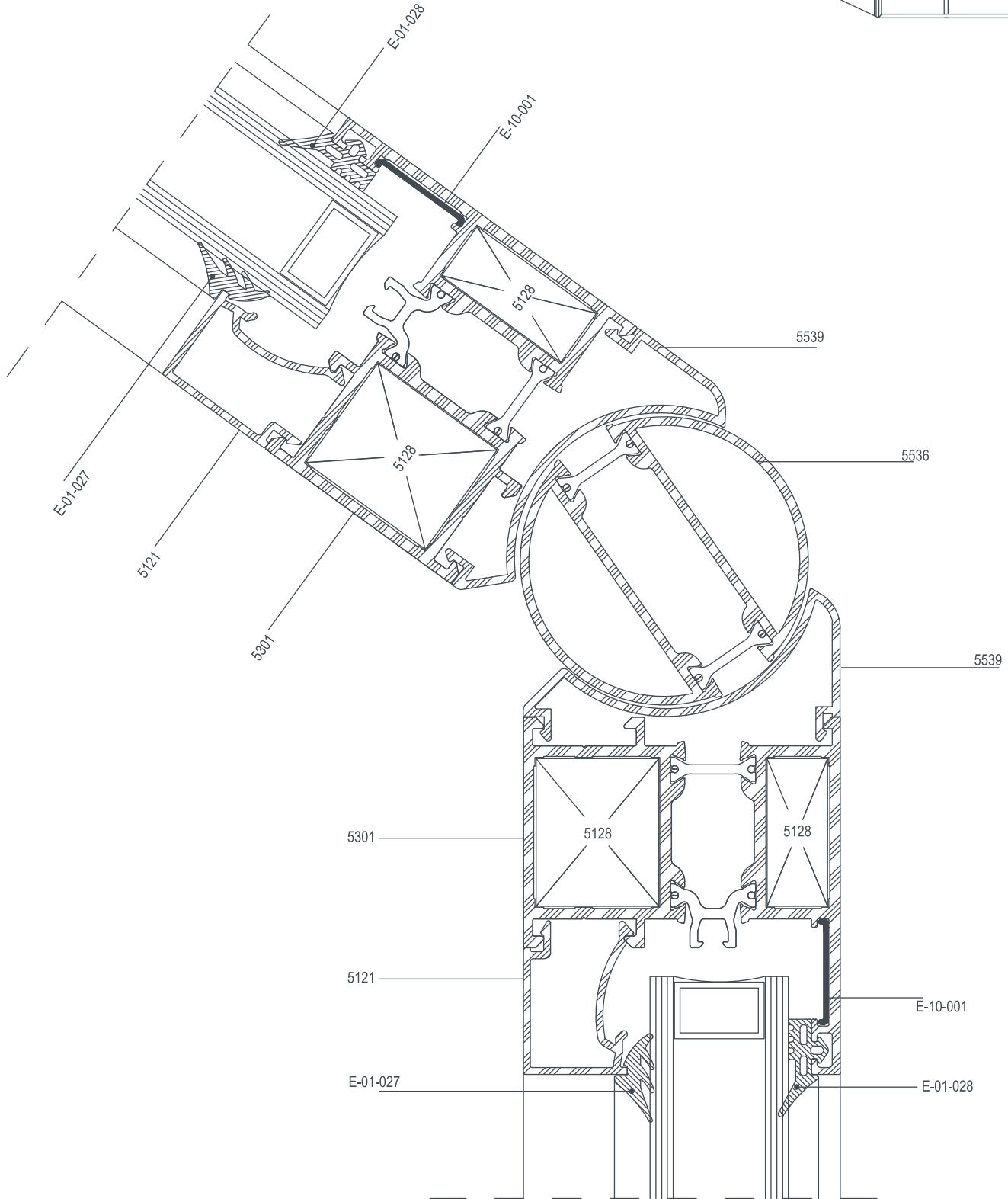
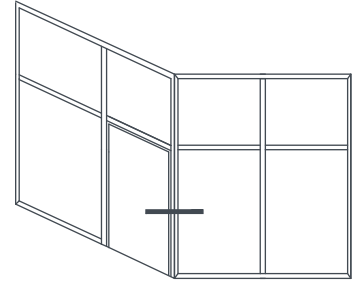



clarks

E 55

DETAYLAR

DETAILS

GİZLİ KANAT PROFİL DETAYLARI E 55
SECRET SASH PROFILE DETAILS E 55

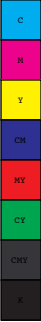



E 55

DETAYLAR / DETAILS

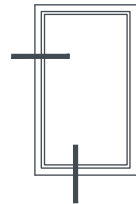
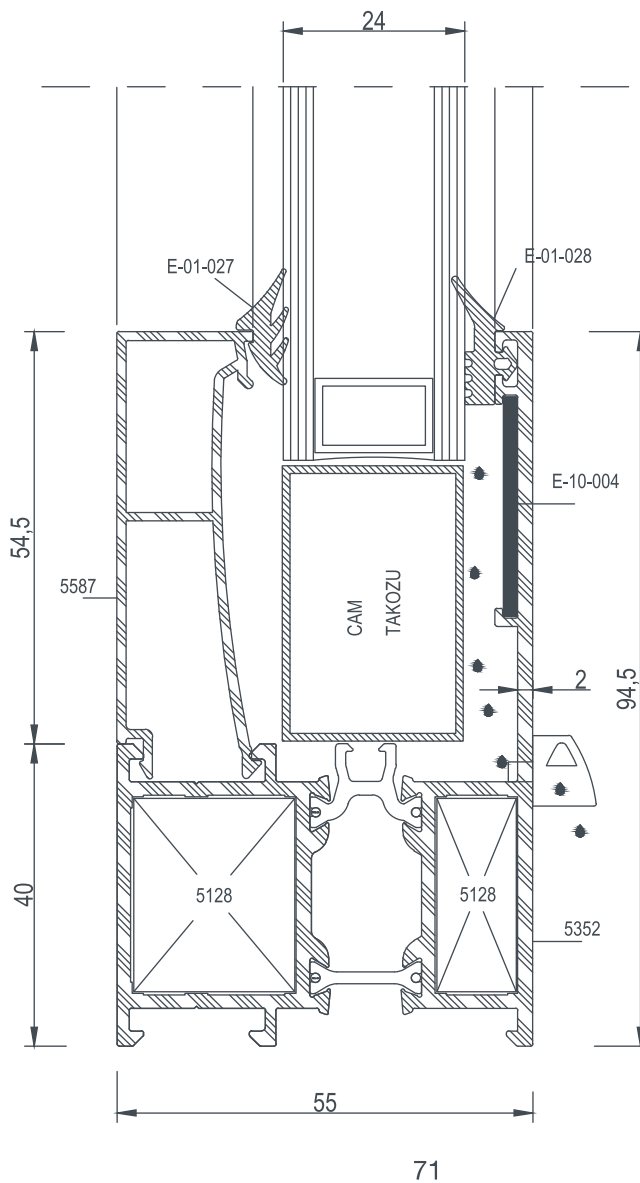
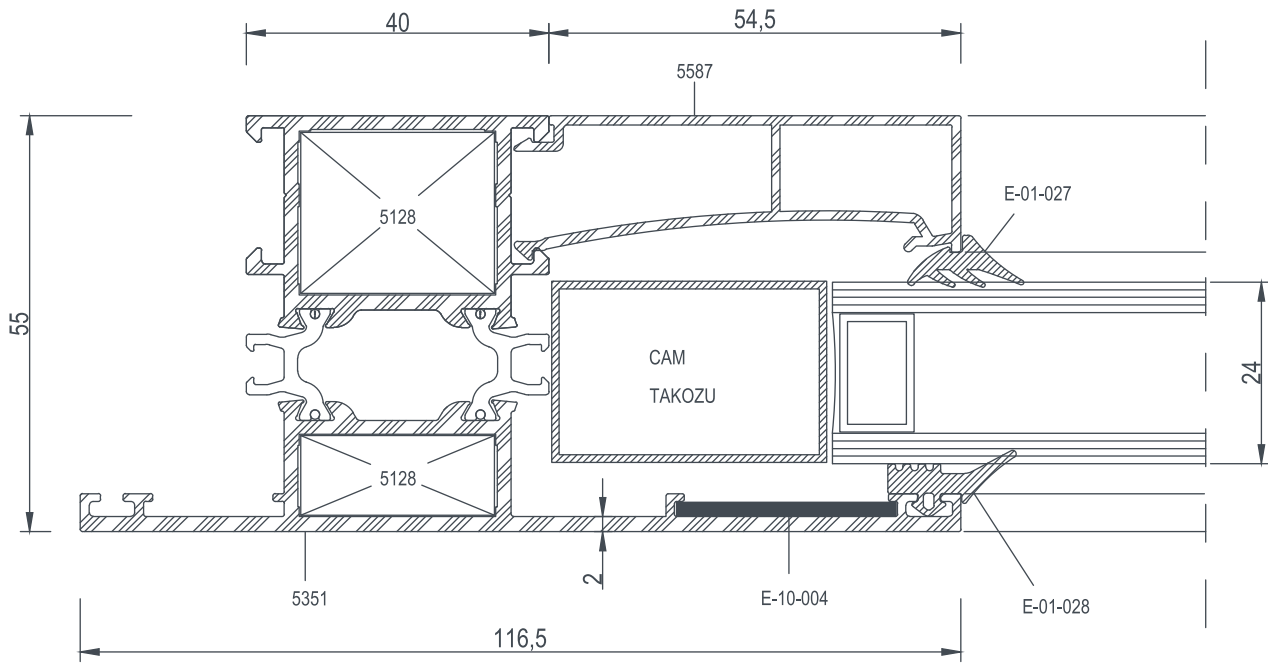



E 55

DETAYLAR / DETAILS

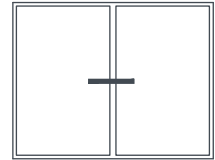
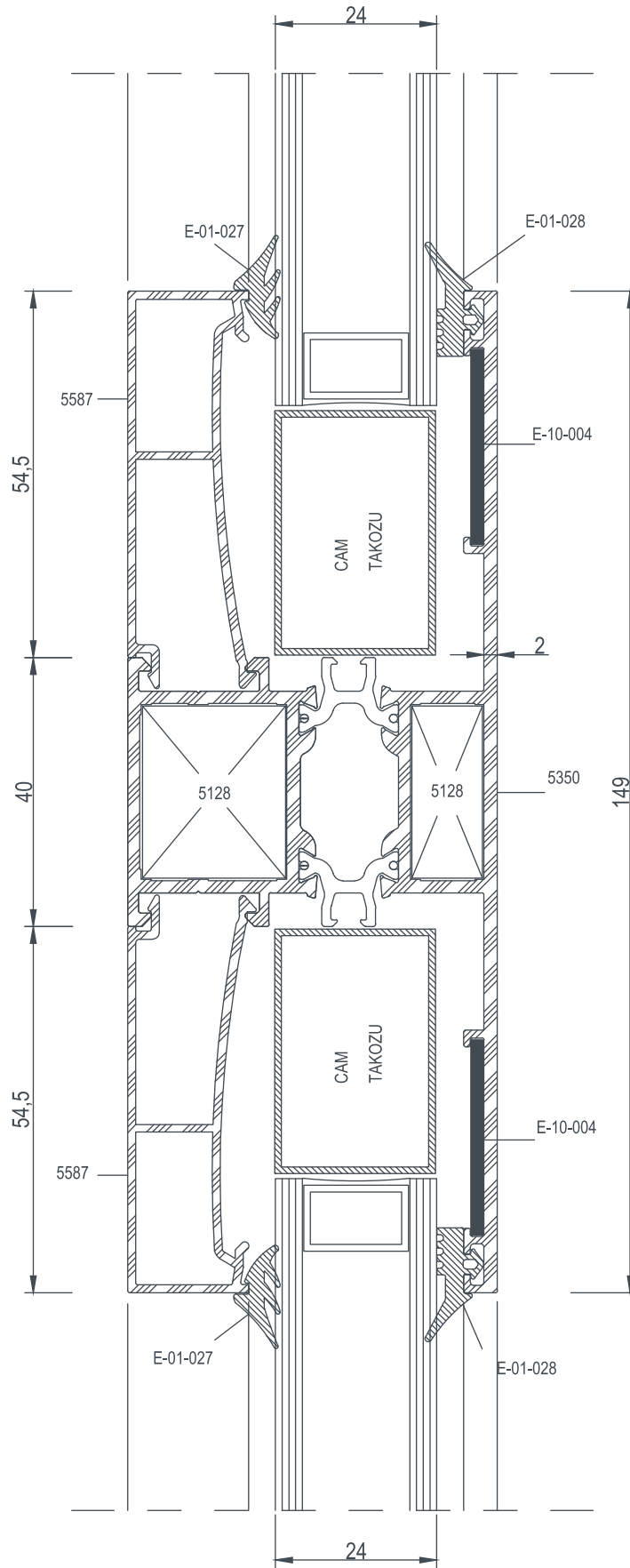



E 55

DEAYLAR / DETAILS

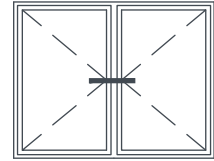
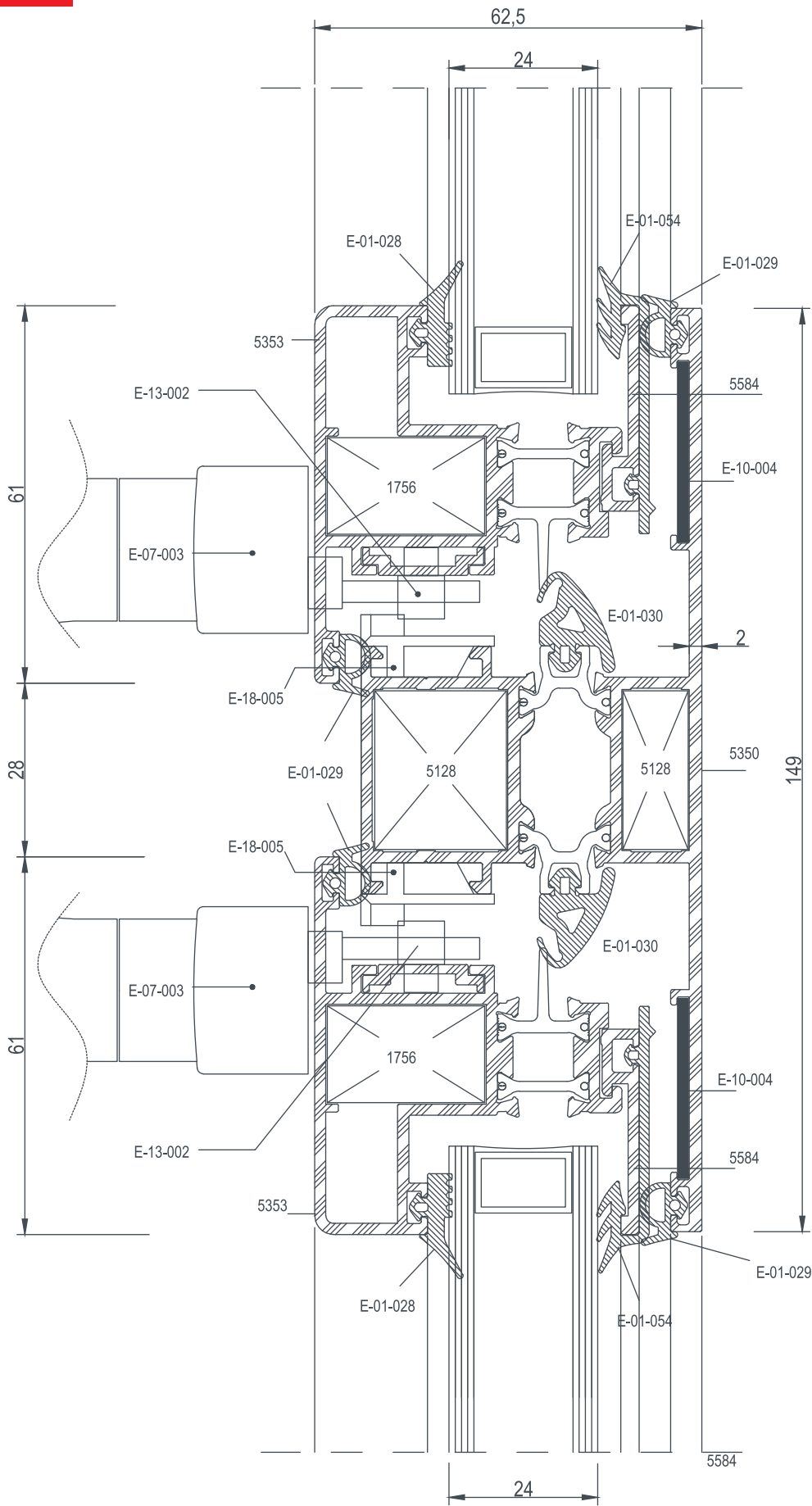



E 55

DETAYLAR / DETAILS

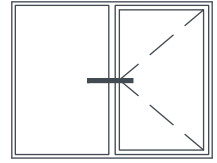
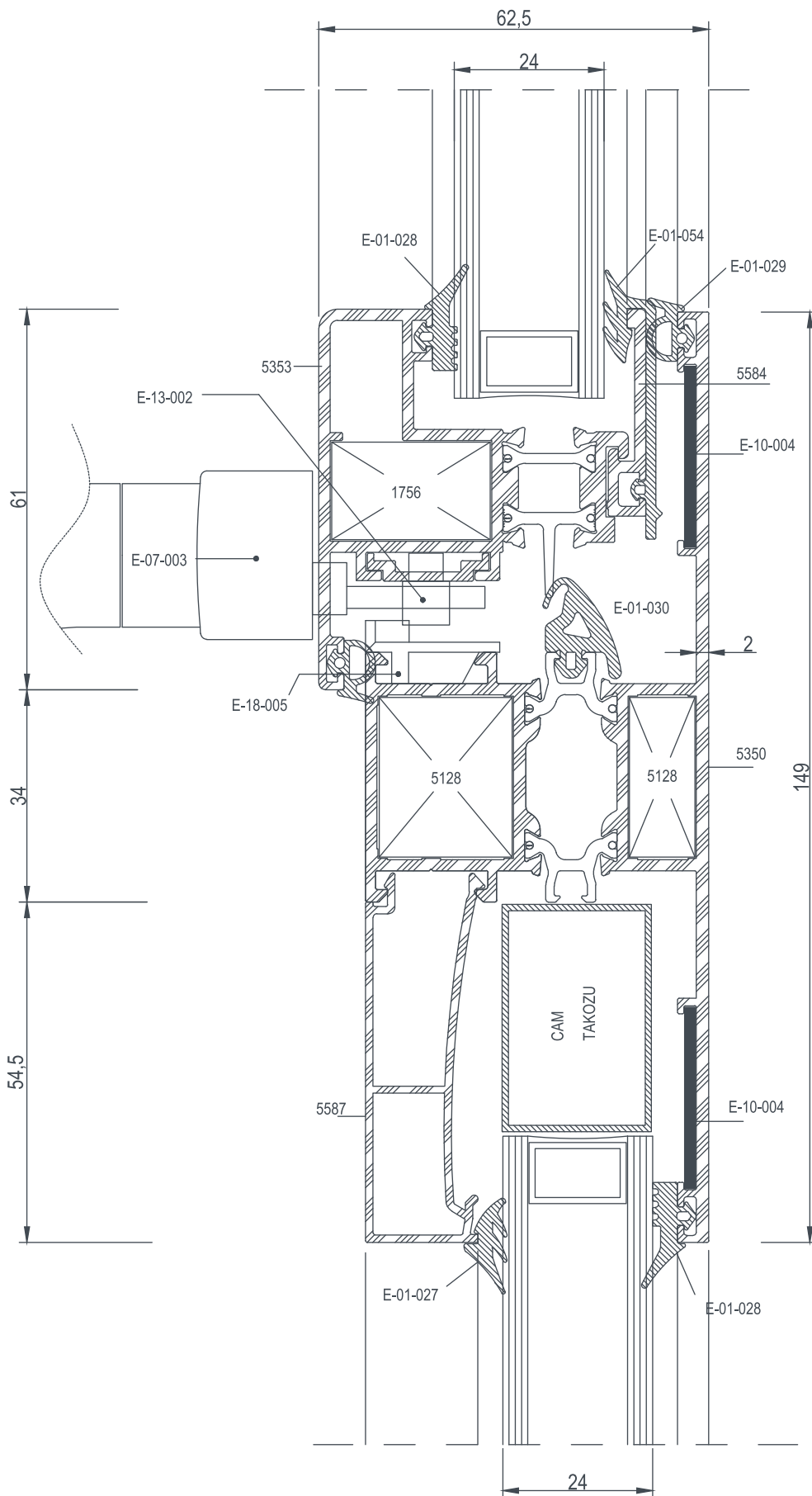



E 55

DETAYLAR / DETAILS

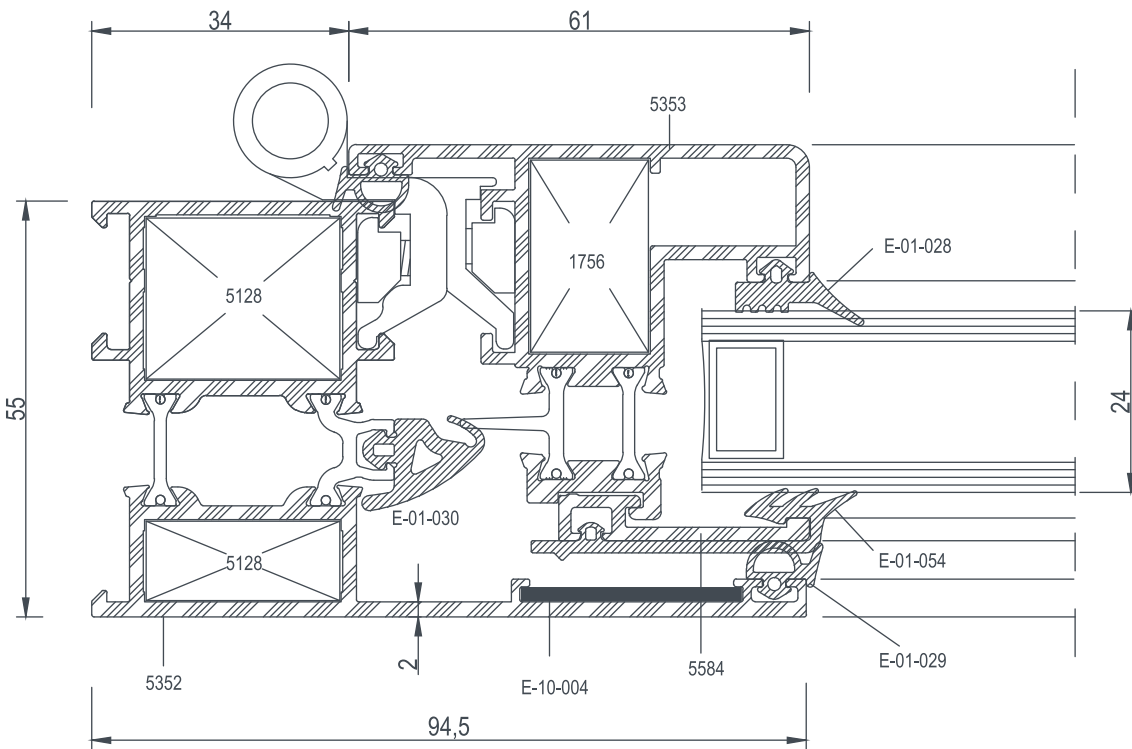
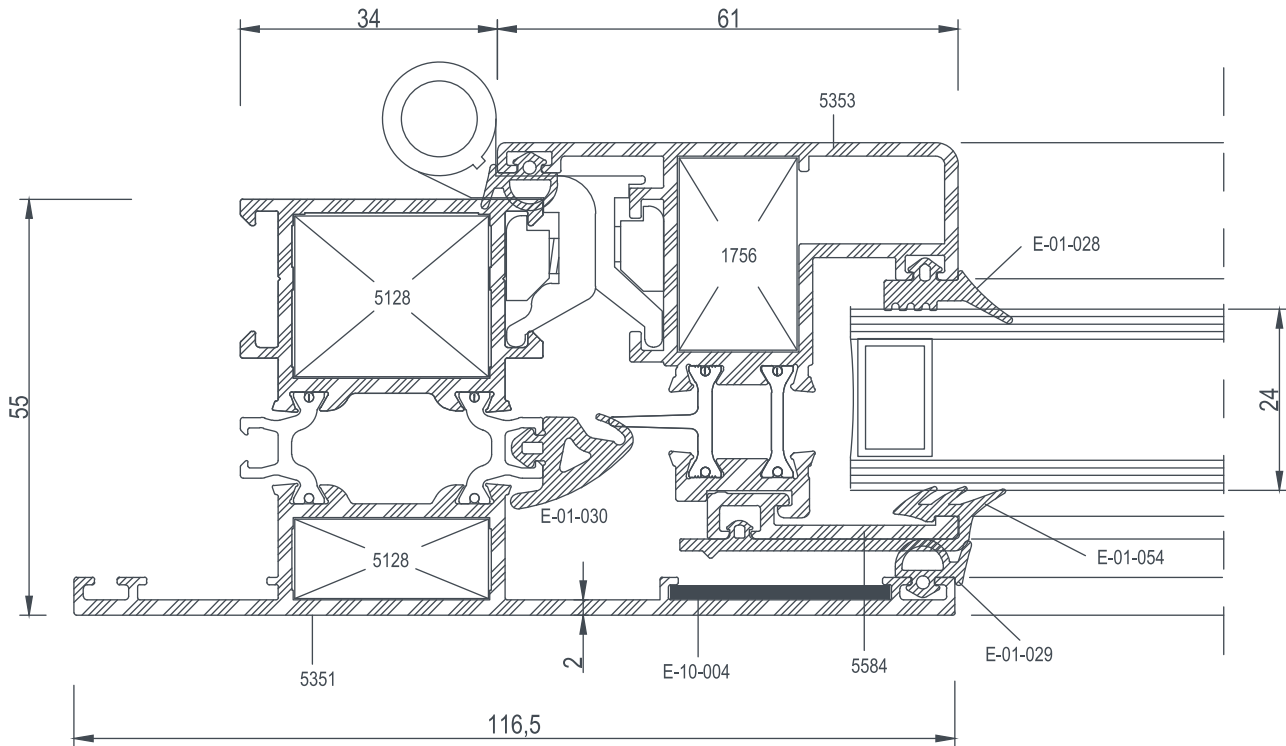

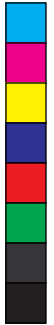

clarks

E 55

AKSESUARLAR
ACCESSORIES











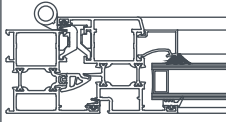
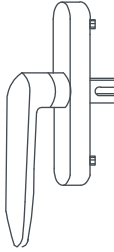
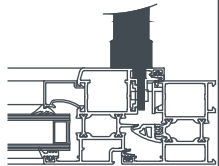

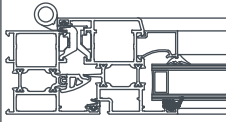
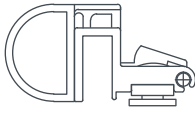
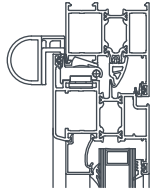

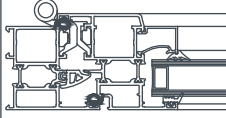
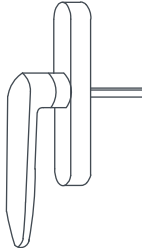
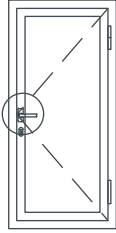
E 55

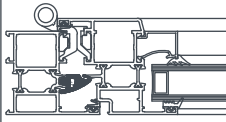
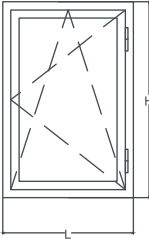
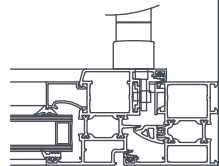
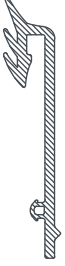
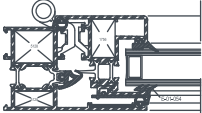

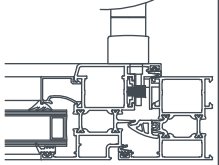

AKSESUARLAR / ACCESSORIES

	<p>E-01-027</p> <p>iç cam fitili inside gasket</p> <p>54 gr/mt</p>			<p>E-07-003</p> <p>ispanyolet Kol Window handle</p>	
	<p>E-01-028</p> <p>Dış cam fitili outside gasket</p> <p>60 gr/mt</p>			<p>E-07-004</p> <p>Vasistas Mandal Vasistas Spring</p>	
	<p>E-01-029</p> <p>Dış Bini Fitili Acoustical Gasket</p> <p>40 gr/mt</p>			<p>E-07-005</p> <p>Kapı Kolu Door Handle</p>	
	<p>E-01-030</p> <p>Tozluk Fitili Central gasket</p> <p>120 gr/mt</p>			<p>E-07-006</p> <p>Çift Açılım Mekanizması Tilt and Turn Mechanism</p> <p>L: 570~1000 mm H: 400~1200 mm</p>	
	<p>E-01-054</p> <p>Gizli Kanat Fitili Secret Sash gasket</p> <p>165 gr/mt</p>			<p>E-13-002</p> <p>Tij Pimi Lock Pin</p>	

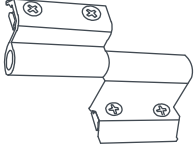
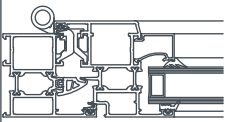

E 55

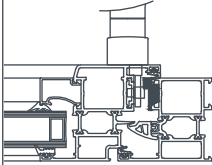
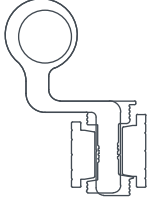
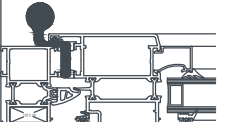
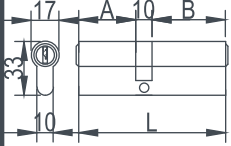
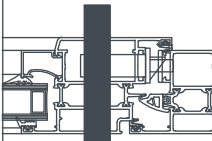
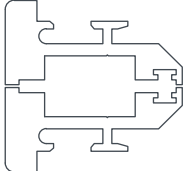
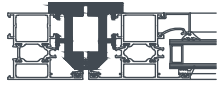
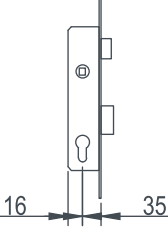
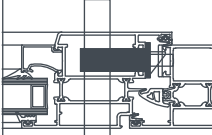
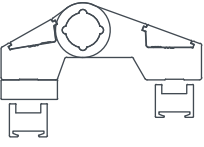
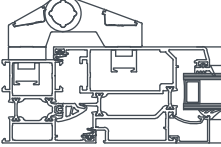

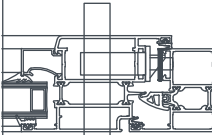
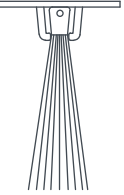
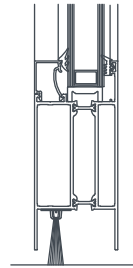
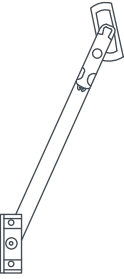
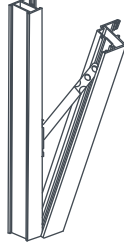
AKSESUARLAR / ACCESSORIES

	E-15-001 Pencere Mentese Window Hinge			E-18-005 Ayarlı Pim Karsılığı Lock Plate							
	E-15-004 Kapı Mentese Door Hinge		 <table border="1" data-bbox="927 1054 1068 1110"> <thead> <tr> <th>A</th> <th>B</th> <th>L</th> </tr> </thead> <tbody> <tr> <td>35</td> <td>45</td> <td>90</td> </tr> </tbody> </table>	A	B	L	35	45	90	E-18-006 Barel Cylinder	
A	B	L									
35	45	90									
	E-15-005 Pivot Mentese Pivot Hinge			E-18-009 Dilli Kilit Mortise Lock							
	E-15-006 Kapı Mentese Door Hinge			E-18-008 Dilli Kilit Karsılığı Forend							
	E-17-003 Kapı Altı Fırçası Brush 1 Mt			E-23-002 Vasistas Makas Vasistas Accessory							

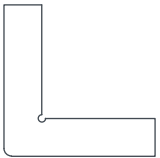
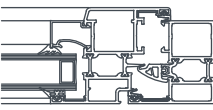
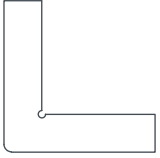
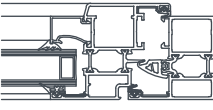
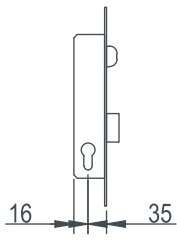
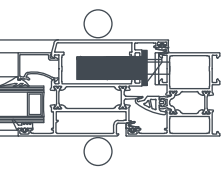

E 55

AKSESUARLAR / ACCESSORIES

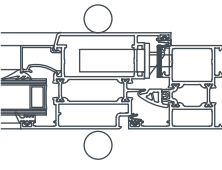
	<p>E-10-001 Köse Çavusu Corner joint</p>				
	<p>STP-274001 Köse Çavusu Corner joint</p>				
	<p>E-18-009-1 Makaralı Kilit Roller Lock</p>				
	<p>E-18-008-1 Makaralı kilit Karsılığı Roller Lock Forend</p>				



clarks

E 64



E 64 - 1.5 - 1.8 - 2.00 T
YALITIMLI PENCERE VE KAPI SİSTEMLERİ

E 64 - 1.5 - 1.8 - 2.00 T
INSULATED WINDOWS & DOORS SYSTEMS





E 64

PROFİL İNDEKS / PROFILE INDEX

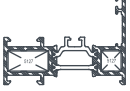
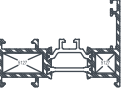
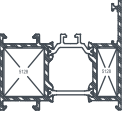
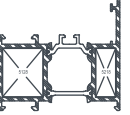
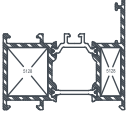
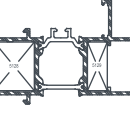
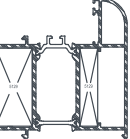
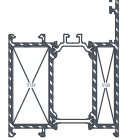
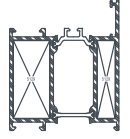
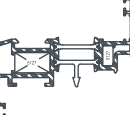
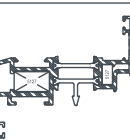
COD Code	PROFİL KESİTİ Profile View	PROFİL AÇIKLAMASI Profile Description	AGIRLIK (kg/m) Weight	Jxx cm ⁴	Jyy cm ⁴	Wxx cm ³	Wyy cm ³
5150		KASA PROFİLİ FRAME PROFILE	1,180	20,60	3,57	5,50	1,37
5100		KASA PROFİLİ FRAME PROFILE	1,241	22,18	3,70	5,92	1,40
5151		KASA PROFİLİ FRAME PROFILE	1,496	26,68	9,90	6,70	3,13
5101		KASA PROFİLİ FRAME PROFILE	1,581	29,04	10,36	7,32	3,27
5140		KASA PROFİLİ FRAME PROFILE	1,640	30,63	10,70	7,73	3,36
5147		KASA PROFİLİ FRAME PROFILE	1,769	44,16	13,93	9,16	4,12
5141		KASA PROFİLİ FRAME PROFILE	2,148	58,23	33,08	10,80	6,78
5152		KASA PROFİLİ FRAME PROFILE	1,876	36,48	24,97	7,14	5,73
5102		KASA PROFİLİ FRAME PROFILE	1,993	39,86	26,58	7,98	6,13
5153		KANAT PROFİLİ SASH PROFILE	1,414	33,06	3,84	7,11	1,84
5103		KANAT PROFİLİ SASH PROFILE	1,508	36,00	4,06	7,69	1,90



E 64

PROFİL İNDEKS / PROFILE INDEX

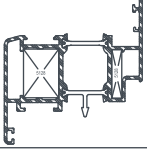
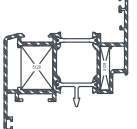
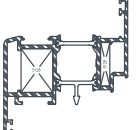
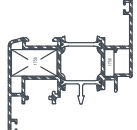
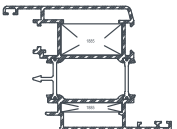
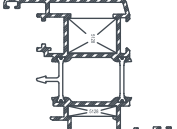
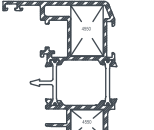
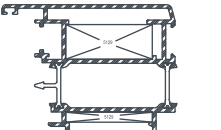
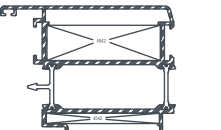
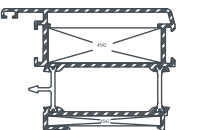
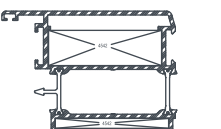
COD Code	PROFİL KESİTİ Profile View	PROFİL AÇIKLAMASI Profile Description	AGIRLIK (kg/m) Weight	Jxx cm4	Jyy cm4	Wxx cm3	Wyy cm3
5154		KANAT PROFİLİ SASH PROFILE	1,717	42,30	11,25	8,54	3,95
5104		KANAT PROFİLİ SASH PROFILE	1,846	46,44	12,31	9,43	4,41
5719		KANAT PROFİLİ SASH PROFILE	1,890	49,00	11,75	9,74	4,27
5155		PVC KANALLI PENCERE KANADI PVC CHANNEL SASH PROFILE	1,657	40,35	9,33	8,11	3,50
5156		PVC KANALLI PENCERE KANADI PVC CHANNEL SASH PROFILE	2,126	59,66	24,96	10,24	6,20
5137		PVC KANALLI PENCERE KANADI PVC CHANNEL SASH PROFILE	2,067	54,52	17,66	10,28	5,36
5722		PVC KANALLI PENCERE KANADI PVC CHANNEL SASH PROFILE	1,921	51,40	12,07	10,30	4,45
5138		PVC KANALLI PENCERE KANADI PVC CHANNEL SASH PROFILE	2,635	82,91	44,29	12,48	9,31
5157		İÇE AÇILIR KAPI KANAT PRF. INNER OPENING DOOR SASH PROFILE	2,395	77,03	40,22	11,45	8,21
5139		İÇE AÇILIR KAPI KANAT PRF. INNER OPENING DOOR SASH PROFILE	2,560	82,58	44,80	12,23	9,15
5720		İÇE AÇILIR KAPI KANAT PRF. INNER OPENING DOOR SASH PROFILE	2,639	87,50	45,06	13,13	9,38



E 64

PROFİL İNDEKS / PROFILE INDEX

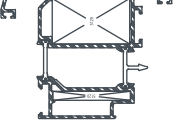
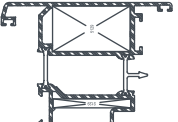
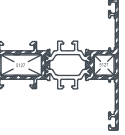
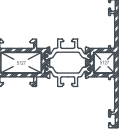
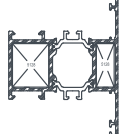
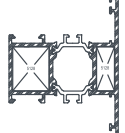
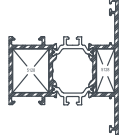
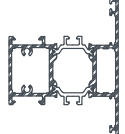
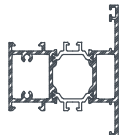
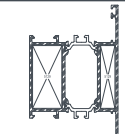
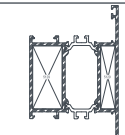
COD Code	PROFİL KESİTİ Profile View	PROFİL AÇIKLAMASI Profile Description	AGIRLIK (kg/m) Weight	Jxx cm ⁴	Jyy cm ⁴	Wxx cm ³	Wyy cm ³
5158		DIŞA AÇILIR KAPI KANAT PRF. OUTWARD OPENING DOOR SASH PROFILE	2,188	46,80	44,31	10,50	8,35
5106		DIŞA AÇILIR KAPI KANAT PRF. OUTWARD OPENING DOOR SASH PROFILE	2,370	52,61	48,31	12,82	9,39
5159		ORTA KAYIT PROFİLİ MULLION PROFILE	1,355	23,17	7,63	6,03	2,21
5107		ORTA KAYIT PROFİLİ MULLION PROFILE	1,424	24,87	7,96	6,48	2,30
5160		ORTA KAYIT PROFİLİ MULLION PROFILE	1,668	28,86	16,63	7,65	3,93
5108		ORTA KAYIT PROFİLİ MULLION PROFILE	1,764	31,44	17,37	8,35	4,13
5721		ORTA KAYIT PROFİLİ MULLION PROFILE	1,833	33,21	17,95	8,81	4,27
5162		VİDALI ORTA KAYIT PROFİLİ SCREW MULLION PROFILE	1,747	30,86	16,90	8,50	4,01
5110		VİDALI ORTA KAYIT PROFİLİ SCREW MULLION PROFILE	1,837	33,34	17,71	9,16	4,21
5161		ORTA KAYIT PROFİLİ MULLION PROFILE	2,050	37,77	36,26	7,26	9,75
5109		ORTA KAYIT PROFİLİ MULLION PROFILE	2,176	39,96	39,90	10,78	7,67



E 64

PROFİL İNDEKS / PROFILE INDEX

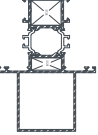
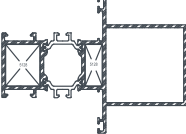
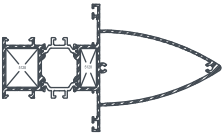
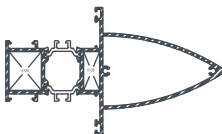
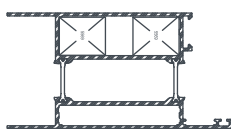
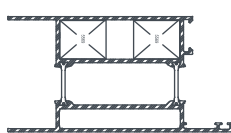
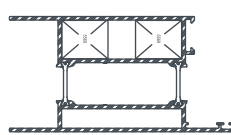
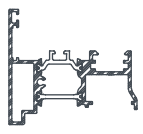
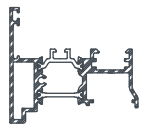
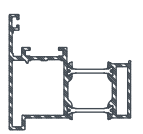
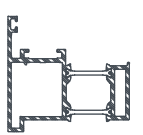
COD Code	PROFİL KESİTİ Profile View	PROFİL AÇIKLAMASI Profile Description	AGIRLIK (kg/m) Weight	Jxx cm ⁴	Jyy cm ⁴	Wxx cm ³	Wyy cm ³
5163		TAKV.ORTA KAYIT PROFİLİ SUPPORTED MULLION PROFILE	2,268	89,26	26,66	15,14	6,34
5111		TAKV.ORTA KAYIT PROFİLİ SUPPORTED MULLION PROFILE	2,478	101,22	29,33	17,58	6,98
5164		TAKV.ORTA KAYIT PROFİLİ SUPPORTED MULLION PROFILE	2,520	135,53	24,50	16,54	5,83
5112		TAKV.ORTA KAYIT PROFİLİ SUPPORTED MULLION PROFILE	2.680	149,56	26,77	18,49	6,37
5165		ETEK PROFİLİ KICK PROFILE	2,372	78,17	45,02	11,48	10,44
5113		ETEK PROFİLİ KICK PROFILE	2,563	85,90	50,78	12,55	11,70
5718		ETEK PROFİLİ KICK PROFILE	2,698	91,23	54,67	13,24	12,52
5166		ÇİFT KANAT ADAPTÖR PROF. DOUBLE SASH ADAPTER PROFILE	1,395	22,88	7,60	5,48	2,28
5114		ÇİFT KANAT ADAPTÖR PROF. DOUBLE SASH ADAPTER PROFILE	1,410	24,98	9,22	6,29	2,91
5167		PİVOT ADAPTÖR PROFİLİ PIVOTING ADAPTER PROFILE	1,472	24,14	8,17	5,64	2,36
5115		PİVOT ADAPTÖR PROFİLİ PIVOTING ADAPTER PROFILE	1,519	27,47	10,27	6,94	3,34



E 64









PROFİL İNDEKS / PROFILE INDEX

COD Code	PROFİL KESİTİ Profile View	PROFİL AÇIKLAMASI Profile Description	AGIRLIK (kg/m) Weight	Jxx cm4	Jyy cm4	Wxx cm3	Wyy cm3
5133		DIŞA AÇILIR KAPI ADAPTÖRÜ OUTWARD OPENING DOOR ADAPTER	1,167	18,55	5,40	5,18	1,87
5116		KÖŞE DÖNÜŞ PROFİLİ CORNER PROFILE	2,045	45,84	40,77	8,61	7,78
5117		TİJ PROFİLİ SASH PROFILE	0,105	----	----	----	----
5134		KÖŞE DÖNÜŞ PROFİLİ CORNER PROFILE	1,349	17,31	15,15	5,41	4,91
5337		ADAPTÖR PROFİLİ ADAPTER PROFILE	0,151	----	----	----	----
5136		ADAPTÖR PROFİLİ ADAPTER PROFILE	0,291	2,36	0,11	0,84	0,14
5135		ADAPTÖR PROFİLİ ADAPTER PROFILE	0,414	7,83	0,43	2,03	0,31
5572		TİJ PROFİLİ SASH PROFILE	0,100	----	----	----	----
5118		CAM ÇITASI PROFİLİ GLAZING BEAD	0,249	----	----	----	----
5119		CAM ÇITASI PROFİLİ GLAZING BEAD	0,251	----	----	----	----
5120		CAM ÇITASI PROFİLİ GLAZING BEAD	0,255	----	----	----	----



E 64









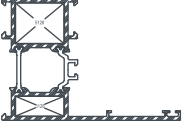
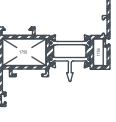

PROFİL İNDEKS / PROFILE INDEX

COD Code	PROFİL KESİTİ Profile View	PROFİL AÇIKLAMASI Profile Description	AGIRLIK (kg/m) Weight	Jxx cm4	Jyy cm4	Wxx cm3	Wyy cm3
5121		CAM ÇITASI PROFİLİ GLAZING BEAD	0,260	----	----	----	----
5122		CAM ÇITASI PROFİLİ GLAZING BEAD	0,267	----	----	----	----
5123		CAM ÇITASI PROFİLİ GLAZING BEAD	0,274	----	----	----	----
5124		CAM ÇITASI PROFİLİ GLAZING BEAD	0,281	----	----	----	----
5125		CAM ÇITASI PROFİLİ GLAZING BEAD	0,292	----	----	----	----
5526		CAM ÇITASI PROFİLİ GLAZING BEAD	0,308	----	----	----	----
5535		CAM ÇITASI PROFİLİ GLAZING BEAD	0,305	----	----	----	----
5536		CAM ÇITASI PROFİLİ GLAZING BEAD	0,312	----	----	----	----
5537		CAM ÇITASI PROFİLİ GLAZING BEAD	0,318	----	----	----	----
5538		CAM ÇITASI PROFİLİ GLAZING BEAD	0,325	----	----	----	----
5539		CAM ÇITASI PROFİLİ GLAZING BEAD	0,331	----	----	----	----



E 64









PROFİL İNDEKS / PROFILE INDEX

COD Code	PROFİL KESİTİ Profile View	PROFİL AÇIKLAMASI Profile Description	AGIRLIK (kg/m) Weight	Jxx cm4	Jyy cm4	Wxx cm3	Wyy cm3
5170		ORTA KAYIT PROFİLİ MULLION PROFILE	2,175	72,89	39,20	9,78	9,09
5171		ORTA KAYIT PROFİLİ MULLION PROFILE	1990	49,54	29,62	7,20	6,32
5172		KASA PROFİLİ FRAME PROFILE	1,796	47,90	19,04	7,58	4,86
5173		KANAT PROFİLİ SASH PROFILE	1,450	29,22	5,65	7,08	2,33
5587		CAM ÇITASI PROFİLİ GLAZING BEAD	0,510	6,36	0,82	1,97	0,75
5588		CAM ÇITASI PROFİLİ GLAZING BEAD	0,521	6,63	1,05	2,00	0,90
5589		CAM ÇITASI PROFİLİ GLAZING BEAD	0,548	7,30	1,18	2,11	0,73
5590		CAM ÇITASI PROFİLİ GLAZING BEAD	0,542	7,13	1,08	2,08	0,73
5591		CAM ÇITASI PROFİLİ GLAZING BEAD	0,534	6,97	1,00	2,06	0,74
1756		KÖŞE TAKOZ PROFİLİ CORNER JOINT	2,474	----	----	----	----
1885		KÖŞE TAKOZ PROFİLİ CORNER JOINT	4,471	----	----	----	----

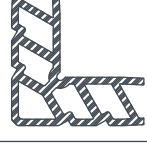

E 64

PROFİL İNDEKS / PROFILE INDEX

COD Code	PROFİL KESİTİ Profile View	PROFİL AÇIKLAMASI Profile Description	AGIRLIK (kg/m) Weight	Jxx cm ⁴	Jyy cm ⁴	Wxx cm ³	Wyy cm ³
4550		KÖŞE TAKOZ PROFİLİ CORNER JOINT	3,581	----	----	----	----
5127		KÖŞE TAKOZ PROFİLİ CORNER JOINT	3,484	----	----	----	----
5128		KÖŞE TAKOZ PROFİLİ CORNER JOINT	3,652	----	----	----	----
5129		KÖŞE TAKOZ PROFİLİ CORNER JOINT	4,618	----	----	----	----
4542		KÖŞE TAKOZ PROFİLİ CORNER JOINT	5,381	----	----	----	----
5570		" U " BAĞ. PROFİLİ " U " LINKING PROFILE	0,393	----	----	----	----
5569		" U " BAĞ. PROFİLİ " U " LINKING PROFILE	0,555	----	----	----	----
5571		" U " BAĞ. PROFİLİ " U " LINKING PROFILE	0,772	----	----	----	----

clarks

E 64

PROFİLLER

PROFILES

E 64 - 1.5 - 1.8 - 2.0 T YALITIMLI SERİ
E 64 - 1.5 - 1.8 - 2.0 T INSULATION SERIES





E 64

PROFİLLER / PROFILES

COD Code	AGIRLIK (kg/m) Weight	Jxx cm4	Jyy cm4	Wxx cm3	Wyy cm3	L m
5150	1,180	20,60	3,57	5,50	1,37	6
5100	1,241	22,18	3,70	5,92	1,40	6
5151	1,496	26,68	9,90	6,70	3,13	6
5101	1,581	29,04	10,36	7,32	3,27	6
5140	1,640	30,63	10,70	7,73	3,36	6

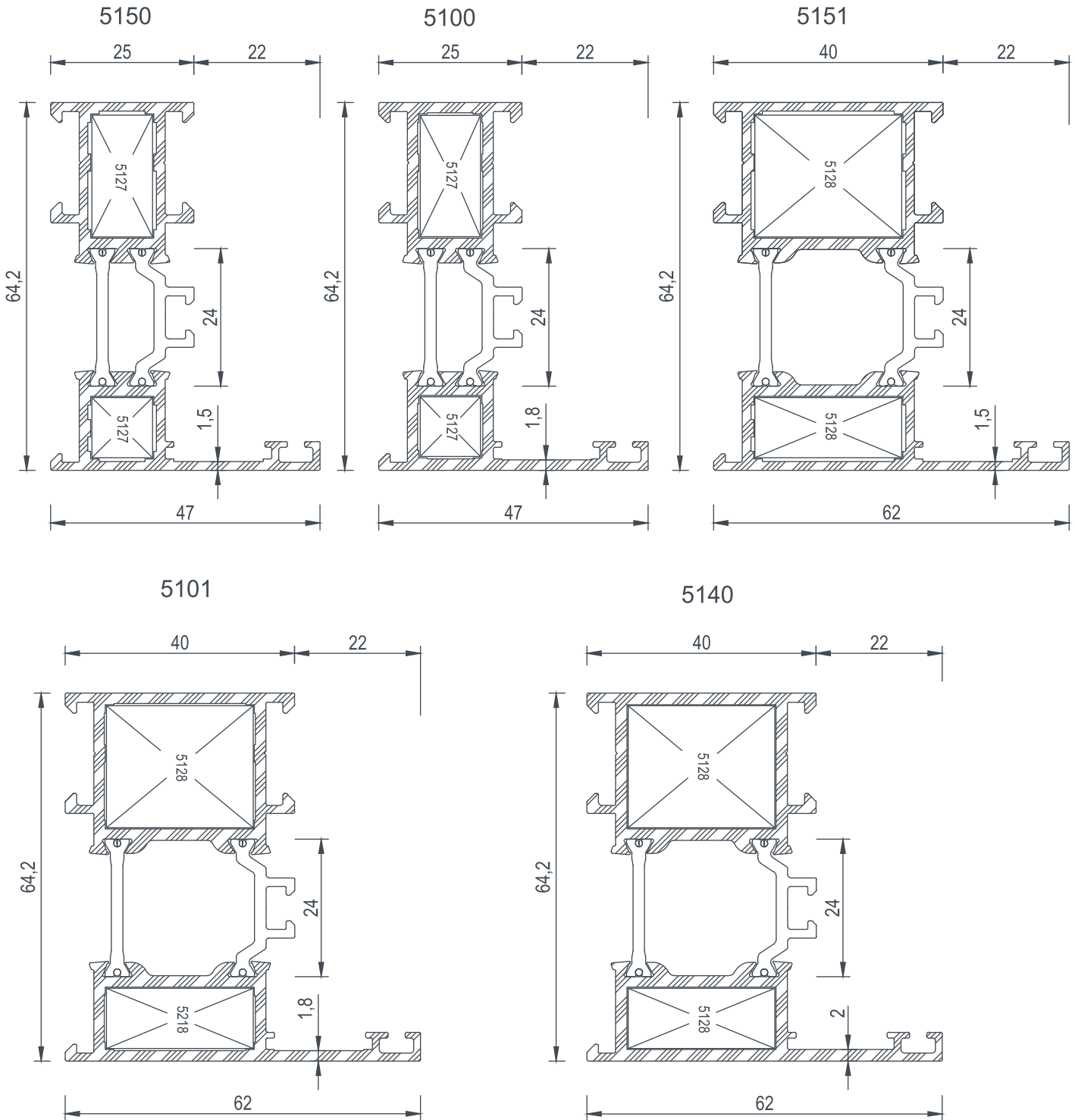



E 64

PROFİLLER / PROFILES

COD Code	AGIRLIK (kg/m) Weight	Jxx cm4	Jyy cm4	Wxx cm3	Wyy cm3	L m
5147	1,769	44,16	13,93	9,16	4,12	6
5141	2,148	58,23	33,08	10,80	6,78	6
5152	1,876	36,48	24,97	7,14	5,73	6
5102	1,993	39,86	26,58	7,98	6,13	6

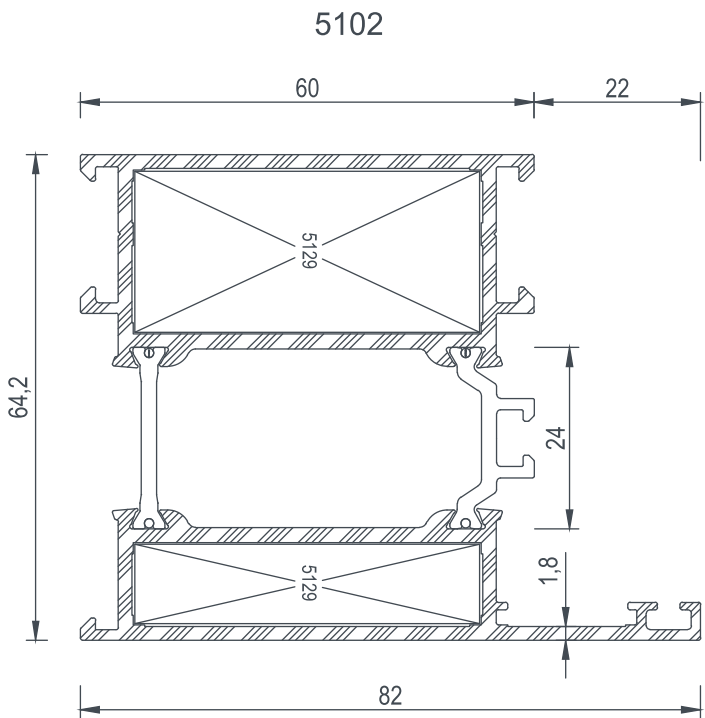
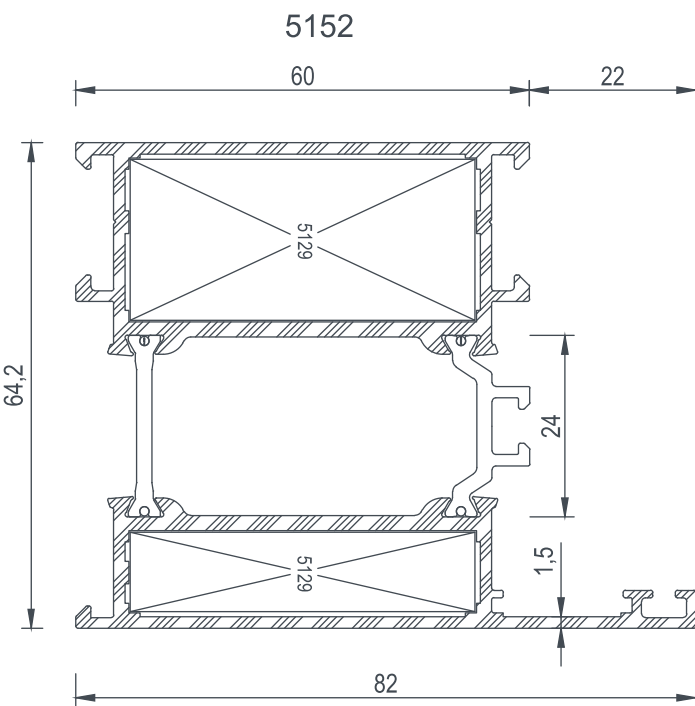
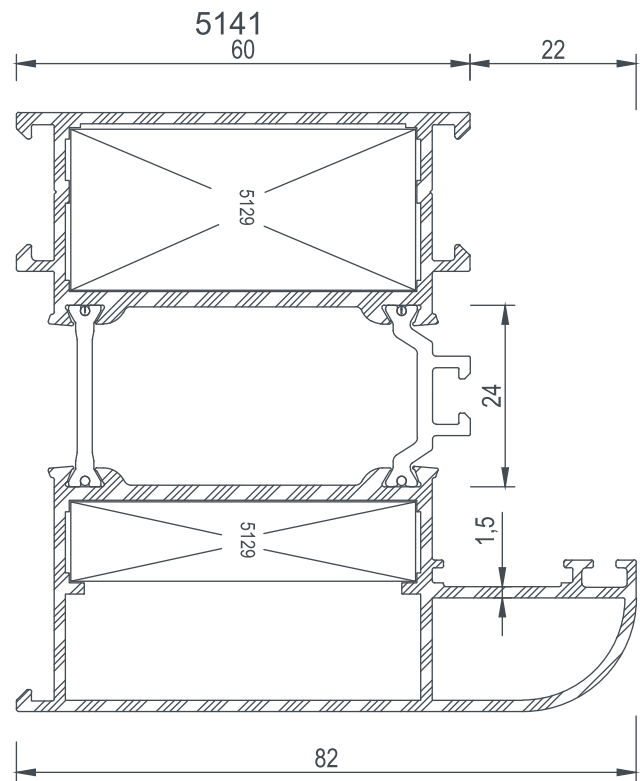
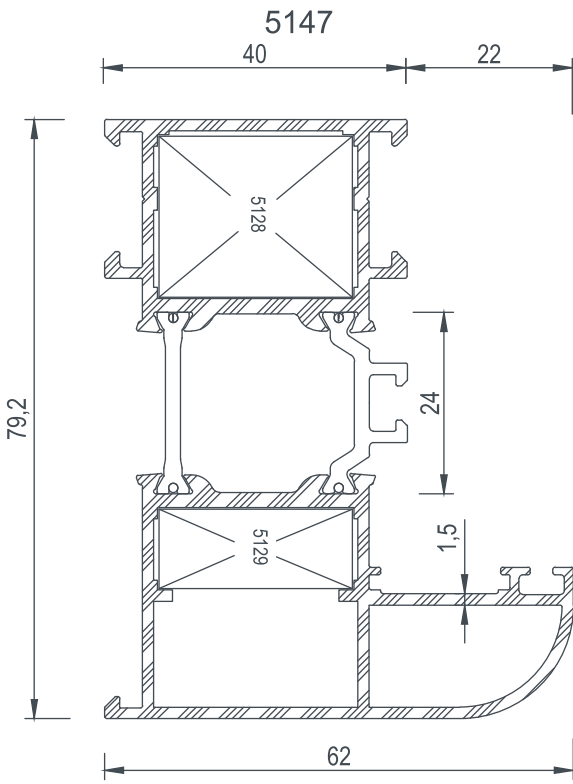



E 64

PROFILLER / PROFILES

COD Code	AGIRLIK (kg/m) Weight	Jxx cm4	Jyy cm4	Wxx cm3	Wyy cm3	L m
5168	1,380	56,55	27,50	4,75	2,30	6
5174	1,770	16,40	46,39	5,4	2,29	6

5168

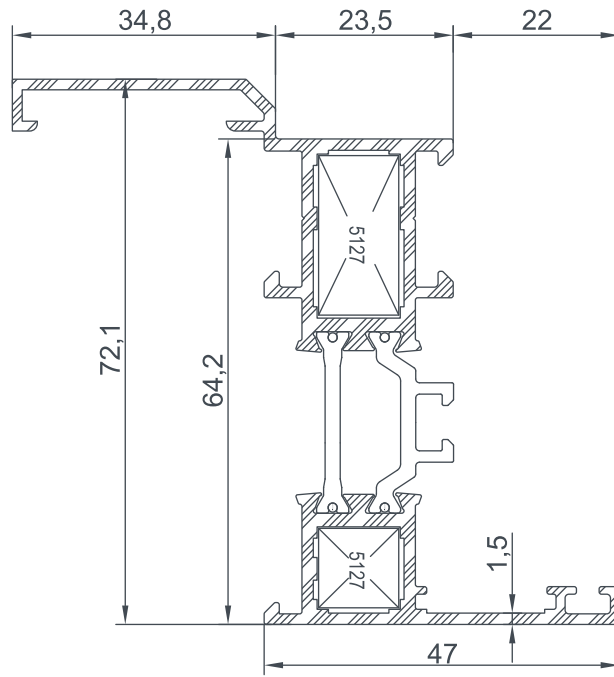

5174

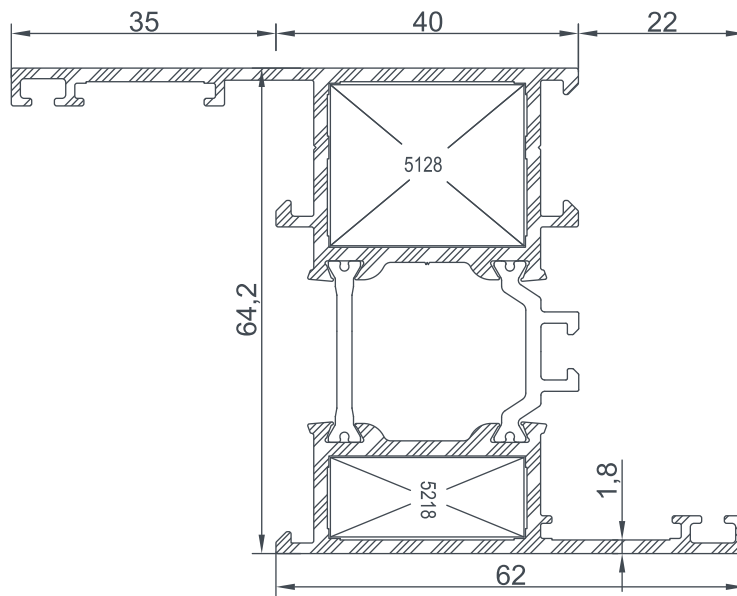

97





E 64

PROFİLLER / PROFILES

COD Code	AGIRLIK (kg/m) Weight	Jxx cm4	Jyy cm4	Wxx cm3	Wyy cm3	L m
5153	1,414	33,06	3,84	7,11	1,84	6
5103	1,508	36,00	4,06	7,69	1,90	6
5154	1,717	42,30	11,25	8,54	3,95	6
5104	1,846	46,44	12,31	9,43	4,41	6

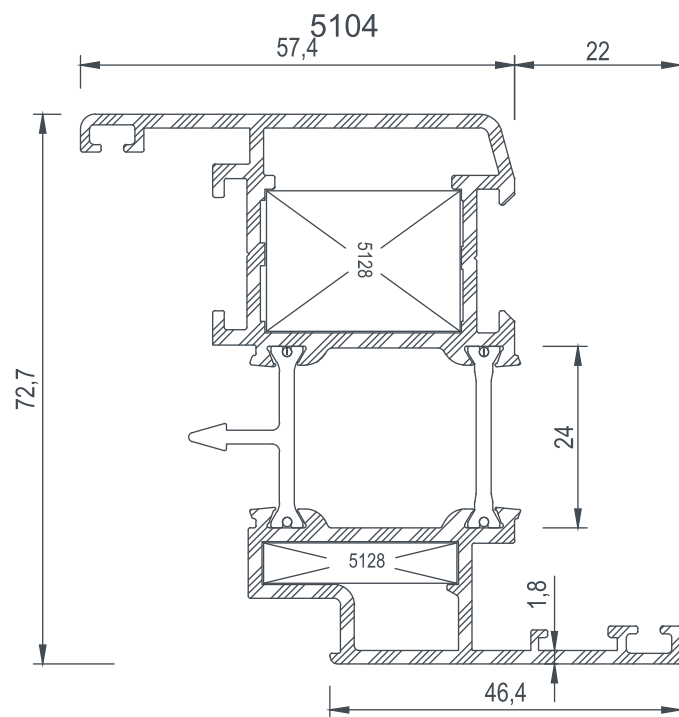
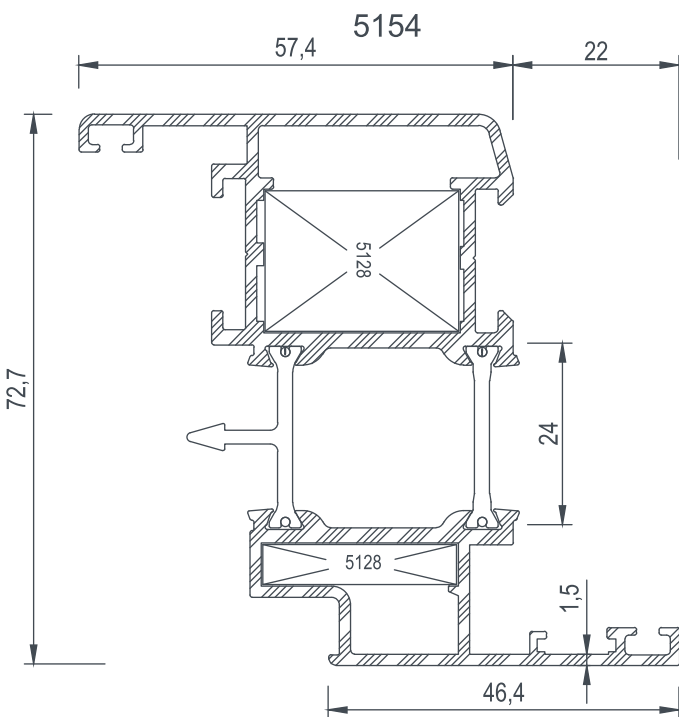
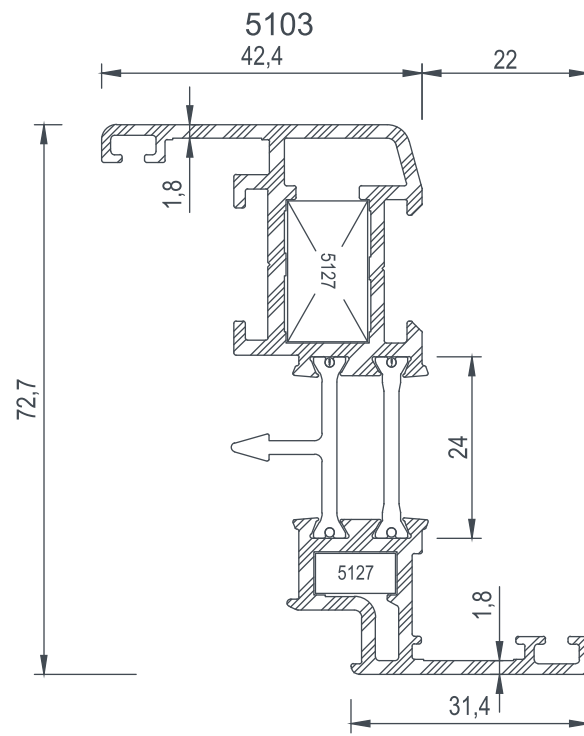
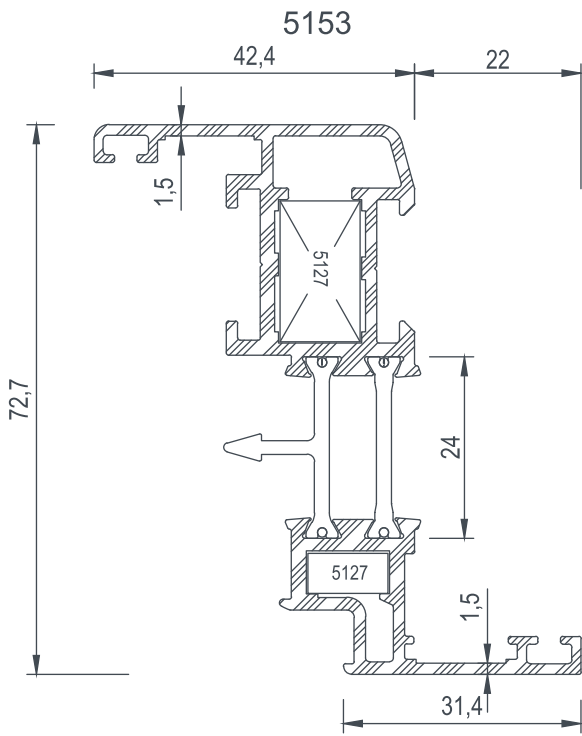



E 64

PROFİLLER / PROFILES

COD Code	AGIRLIK (kg/m) Weight	Jxx cm4	Jyy cm4	Wxx cm3	Wyy cm3	L m
5719	1,890	49,00	11,75	9,74	4,27	6
5155	1,657	40,35	9,33	8,11	3,50	6
5156	2,126	59,66	24,96	10,24	6,20	6

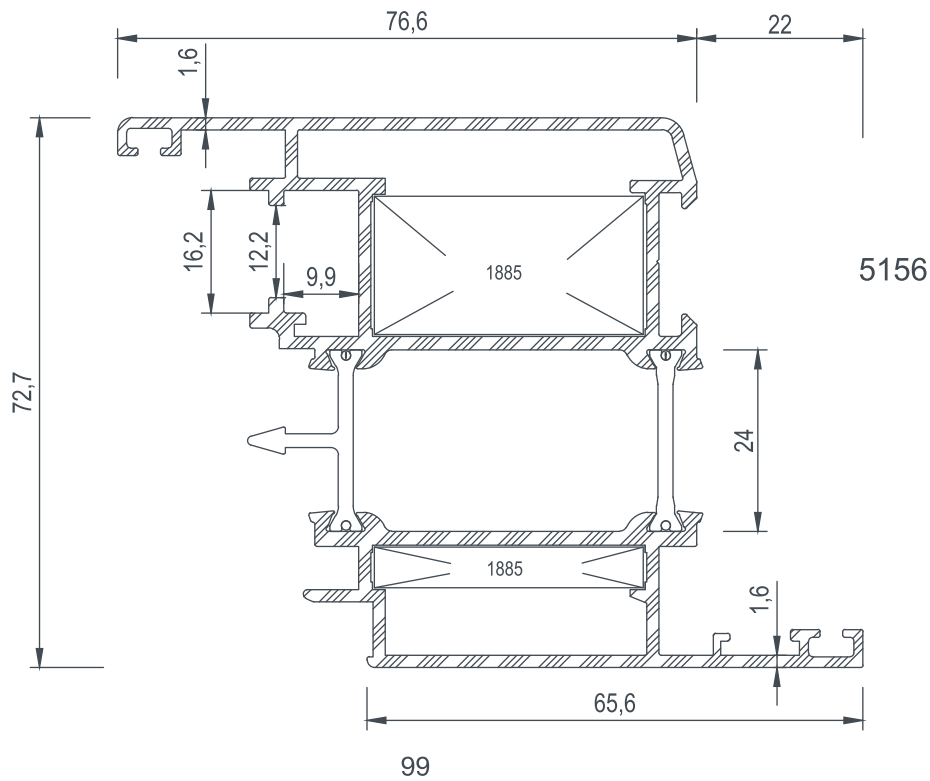
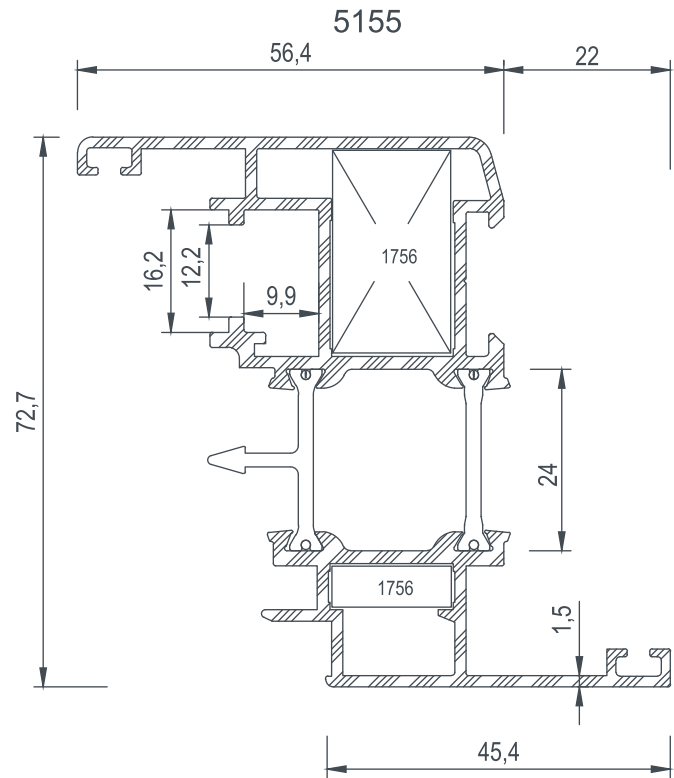
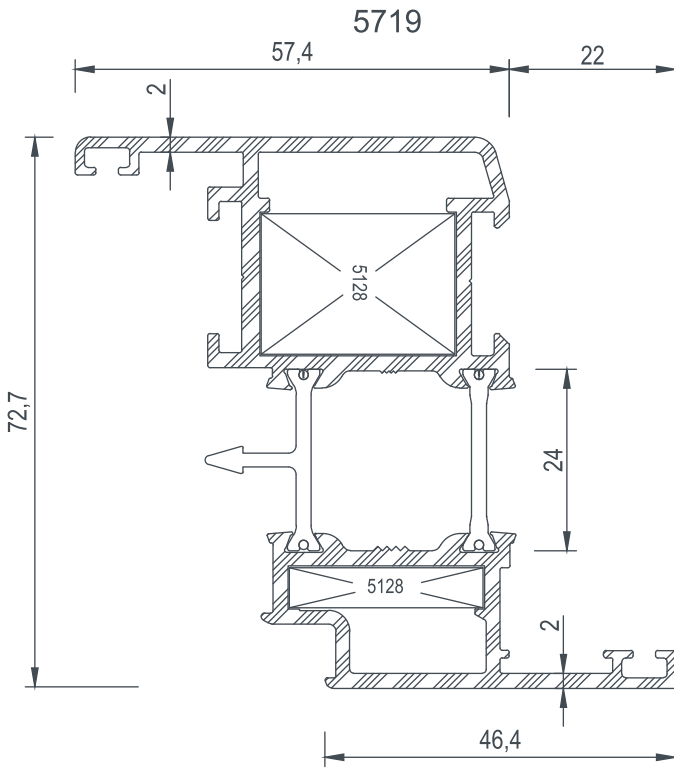



E 64

PROFİLLER / PROFILES

COD Code	AGIRLIK (kg/m) Weight	Jxx cm4	Jyy cm4	Wxx cm3	Wyy cm3	L m
5137	2,067	54,52	17,66	10,28	5,36	6
5722	1,921	51,40	12,07	10,30	4,45	6
5138	2,635	82,91	44,29	12,48	9,31	6

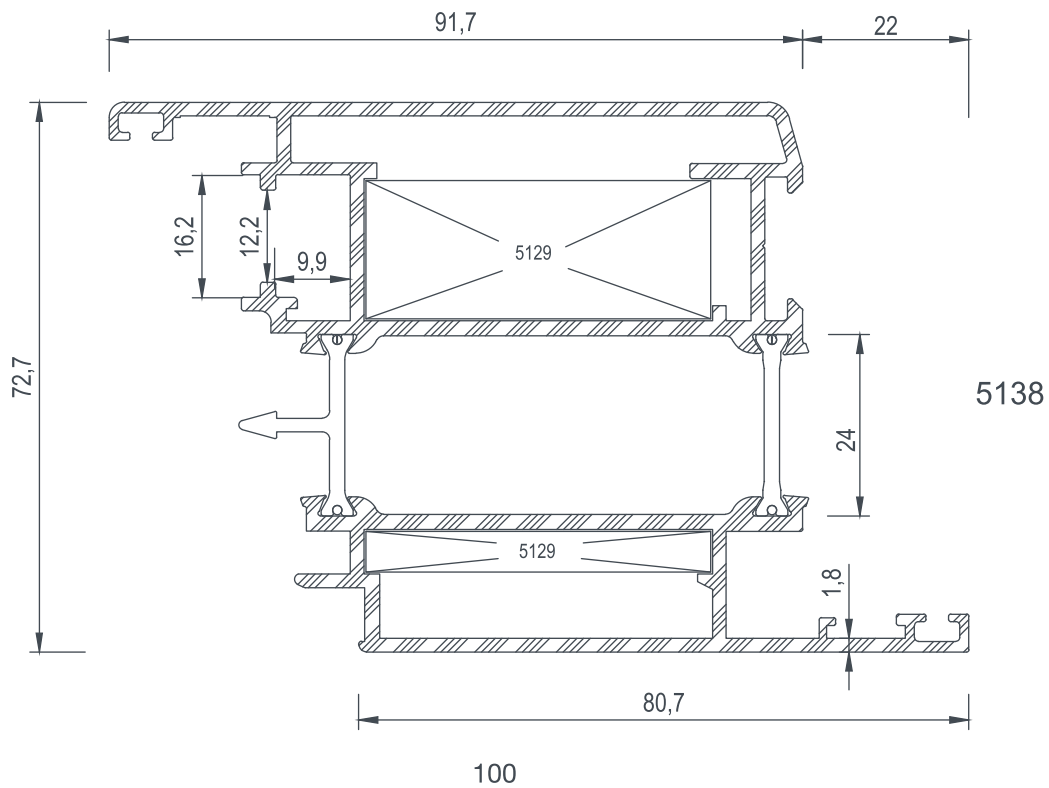
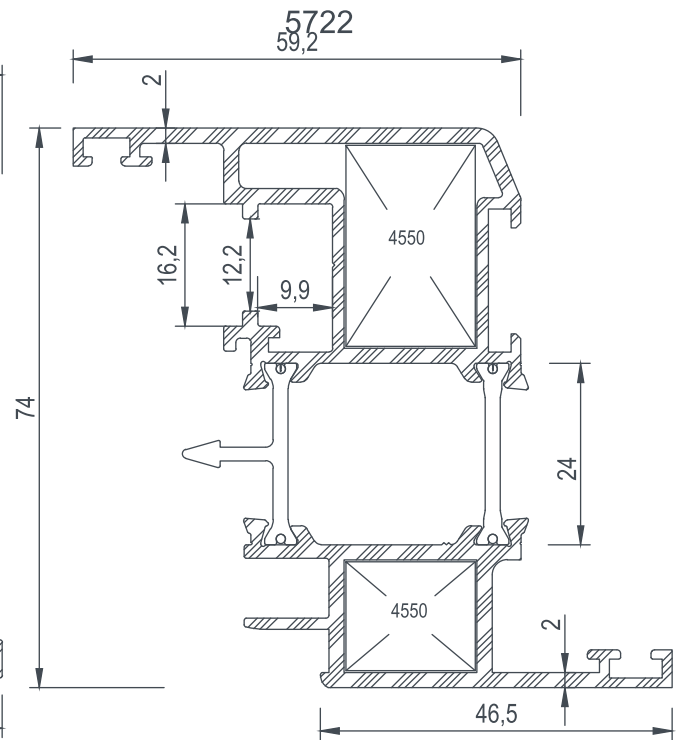
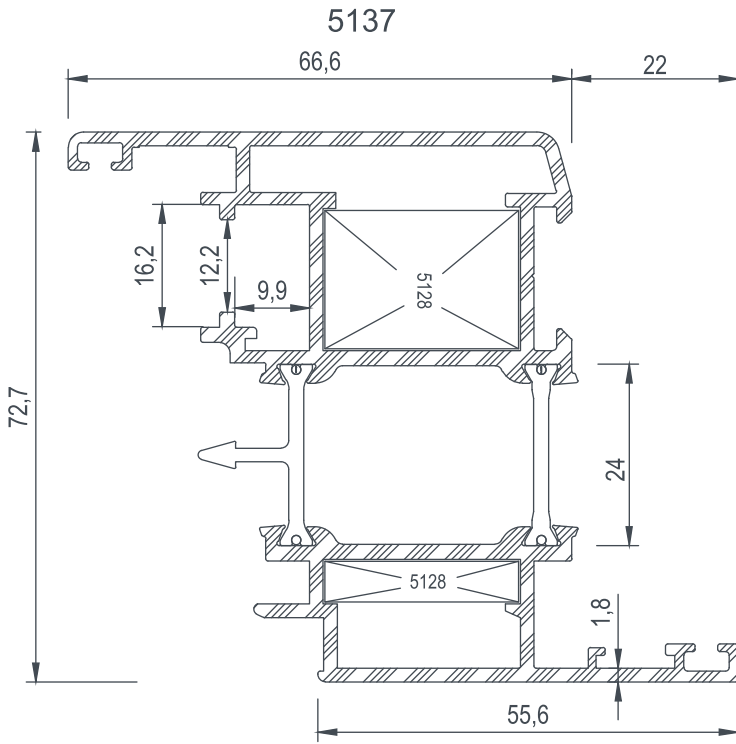



E 64

PROFİLLER / PROFILES

COD Code	AGIRLIK (kg/m) Weight	Jxx cm4	Jyy cm4	Wxx cm3	Wyy cm3	L m
5157	2,395	77,03	40,22	11,45	8,21	6
5139	2,560	82,58	44,80	12,23	9,15	6

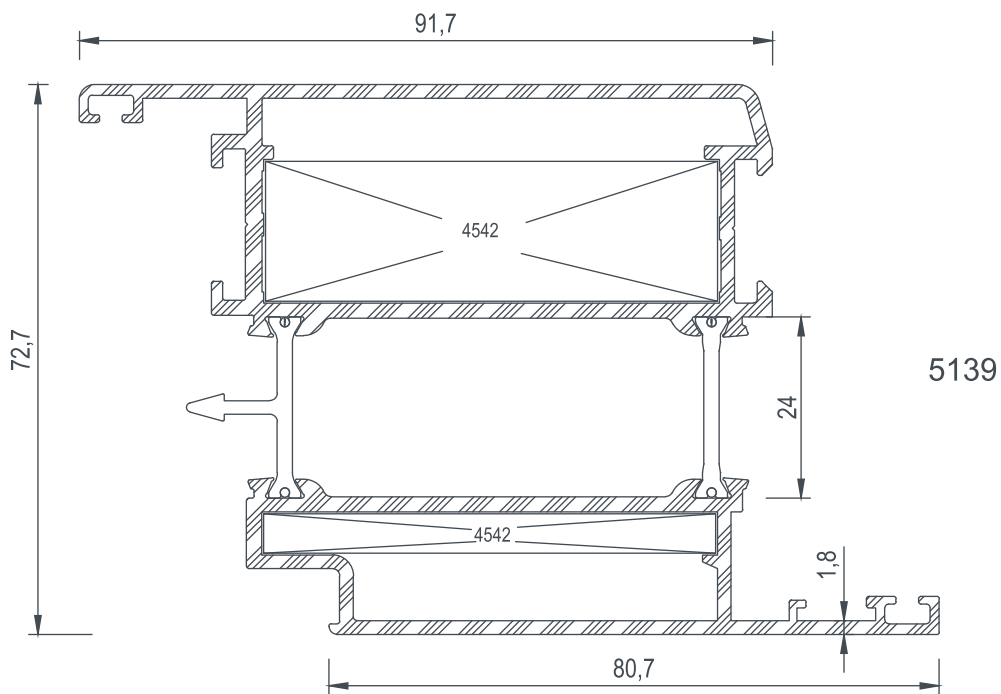
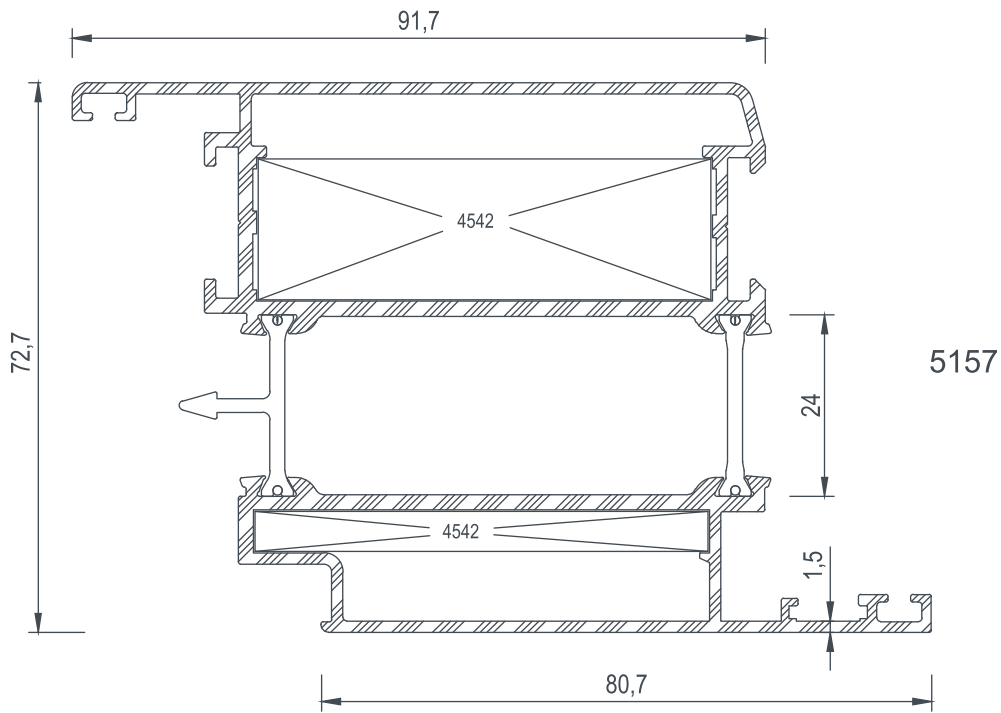

101





E 64

PROFİLLER / PROFILES

COD Code	AGIRLIK (kg/m) Weight	Jxx cm4	Jyy cm4	Wxx cm3	Wyy cm3	L m
5720	2,639	87,50	45,06	13,13	9,38	6
5158	2,188	46,8	44,31	10,50	8,35	6
5106	2,370	52,61	48,31	12,82	9,39	6

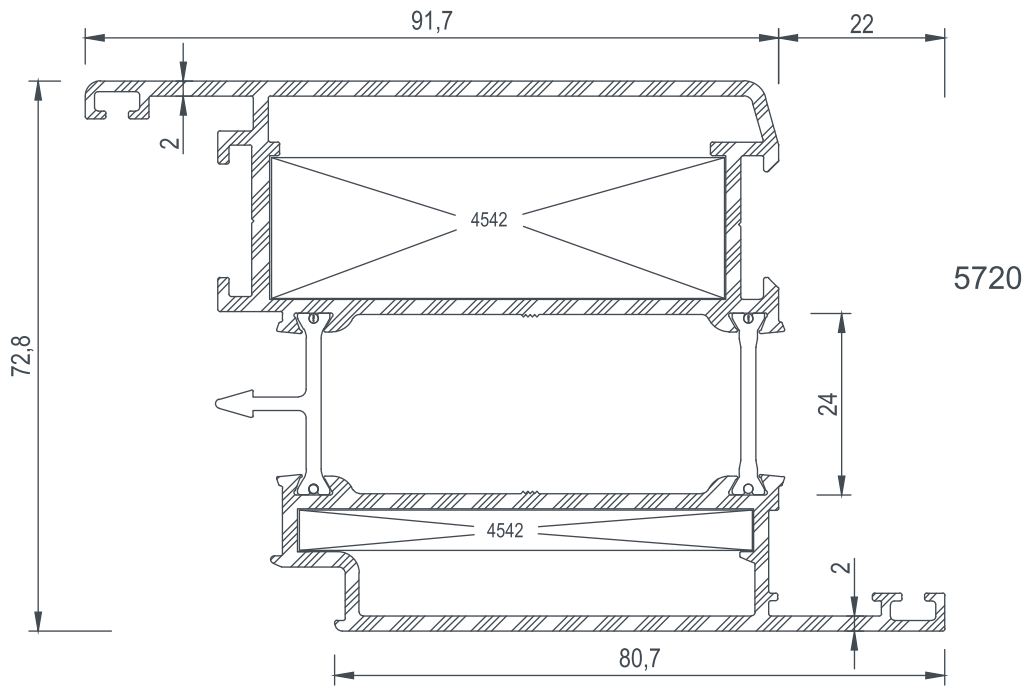

5158

5106

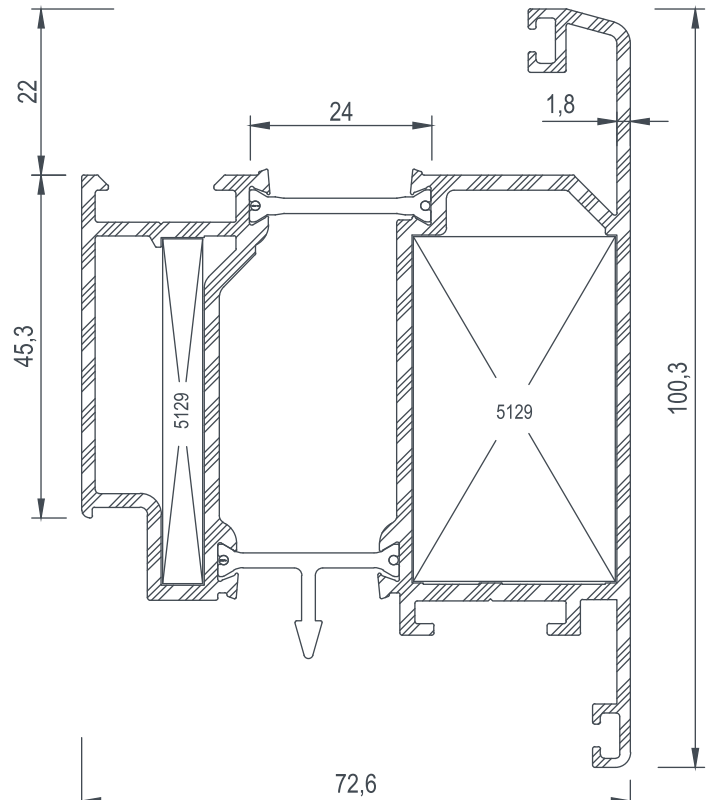
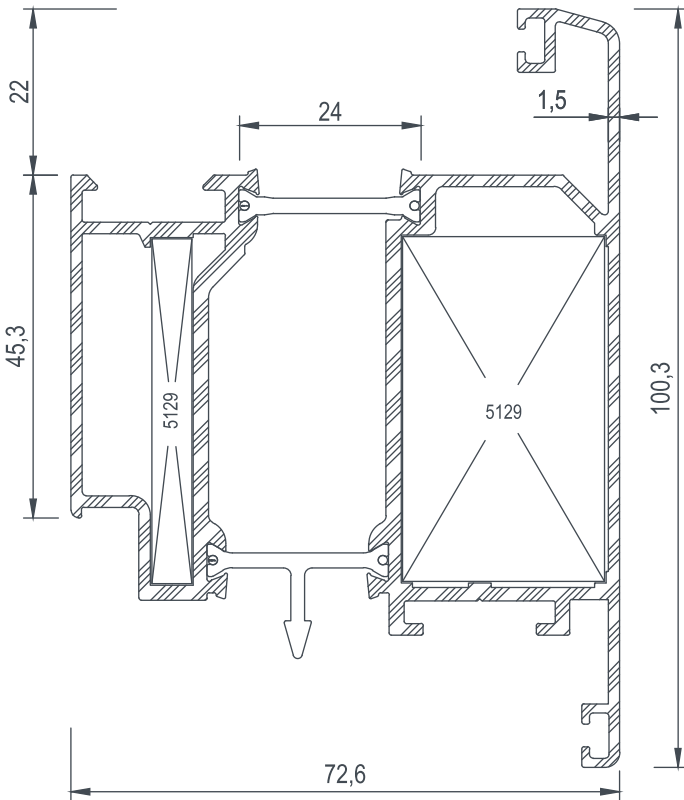

102





E 64

PROFİLLER / PROFILES

COD Code	AGIRLIK (kg/m) Weight	Jxx cm4	Jyy cm4	Wxx cm3	Wyy cm3	L m
5159	1,355	23,17	7,63	6,03	2,21	6
5107	1,424	24,87	7,96	6,48	2,30	6
5160	1,668	28,86	16,53	7,65	3,93	6
5108	1,764	31,44	17,37	8,35	4,13	6

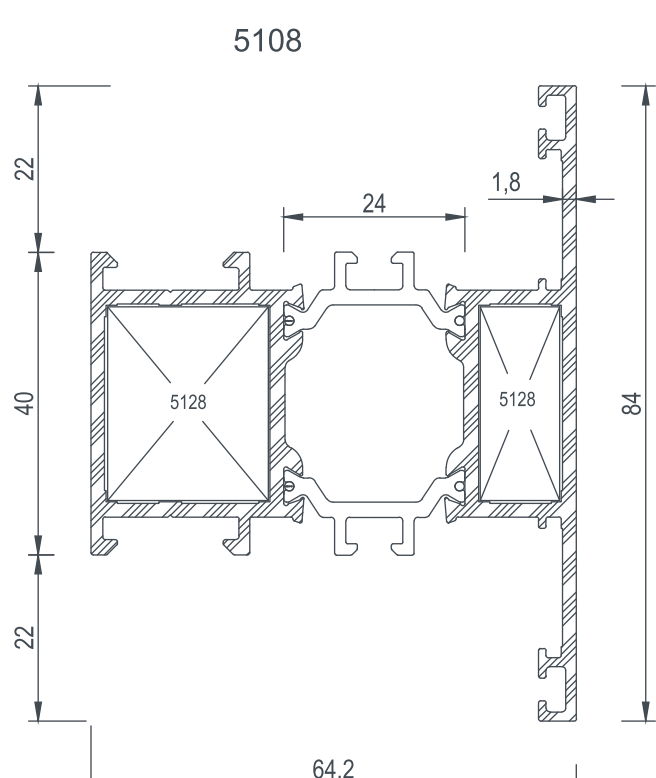
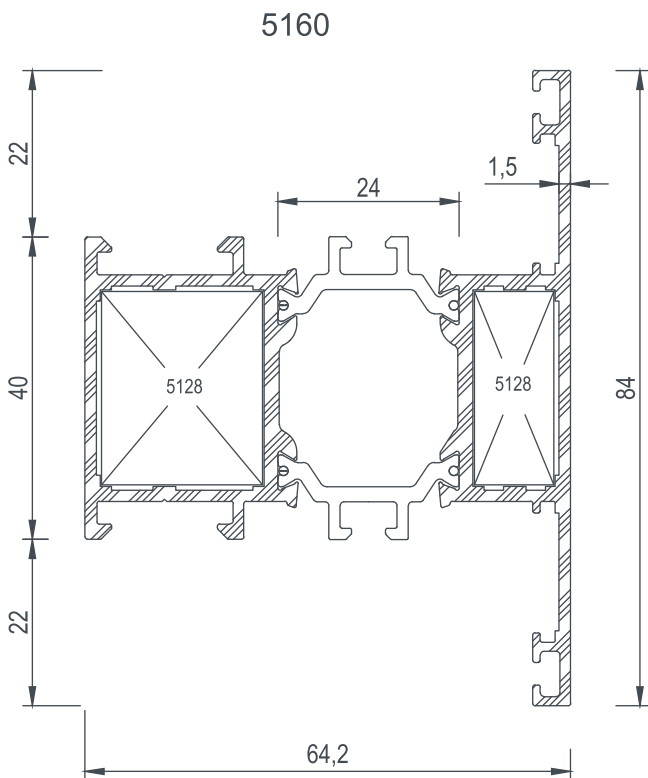
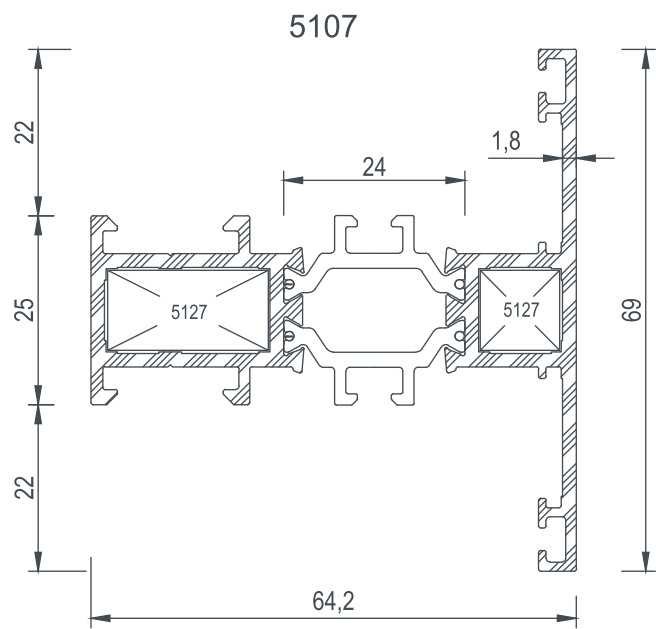
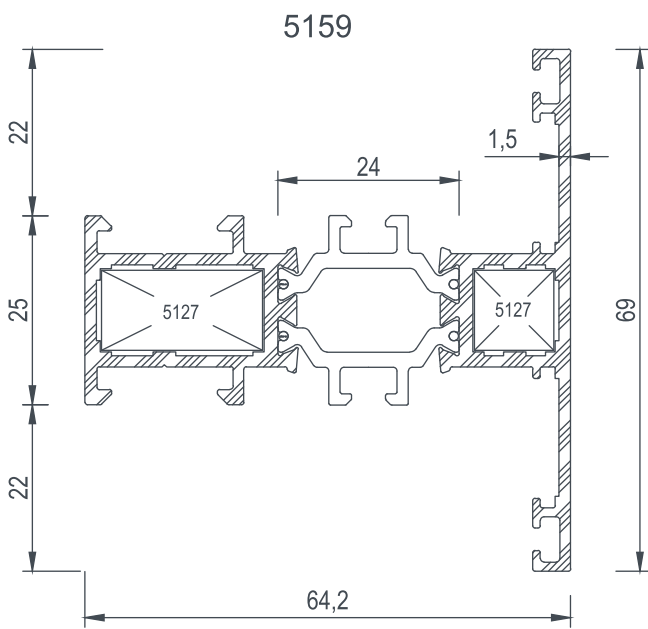



E 64

PROFİLLER / PROFILES

COD Code	AGIRLIK (kg/m) Weight	Jxx cm4	Jyy cm4	Wxx cm3	Wyy cm3	L m
5721	1,833	33,21	17,95	8,81	4,27	6
5162	1,747	30,86	16,90	8,50	4,01	6
5110	1,837	33,34	17,71	9,16	4,21	6
5161	2,050	37,77	36,26	7,26	9,75	6

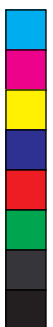
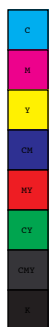
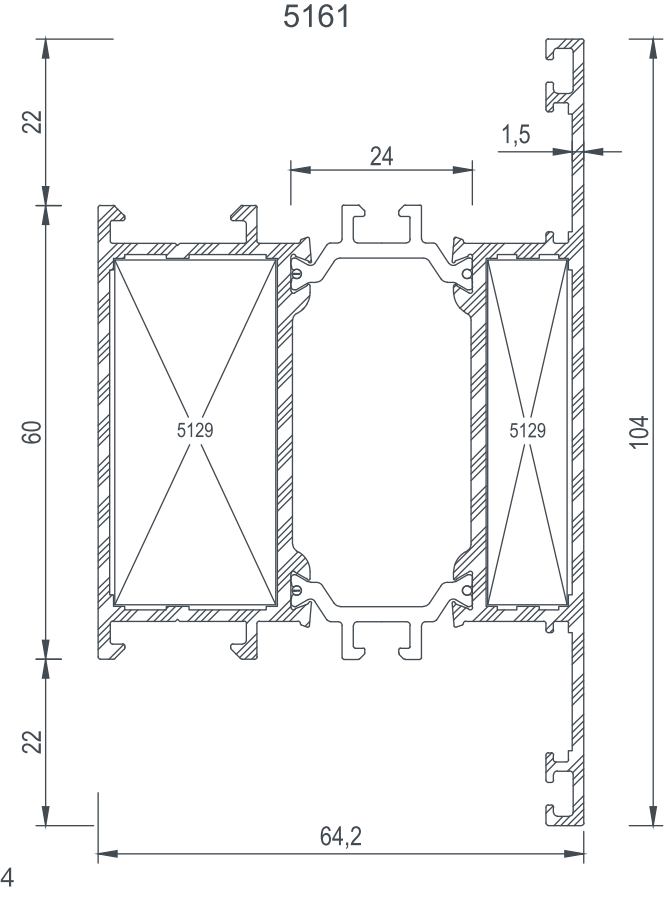
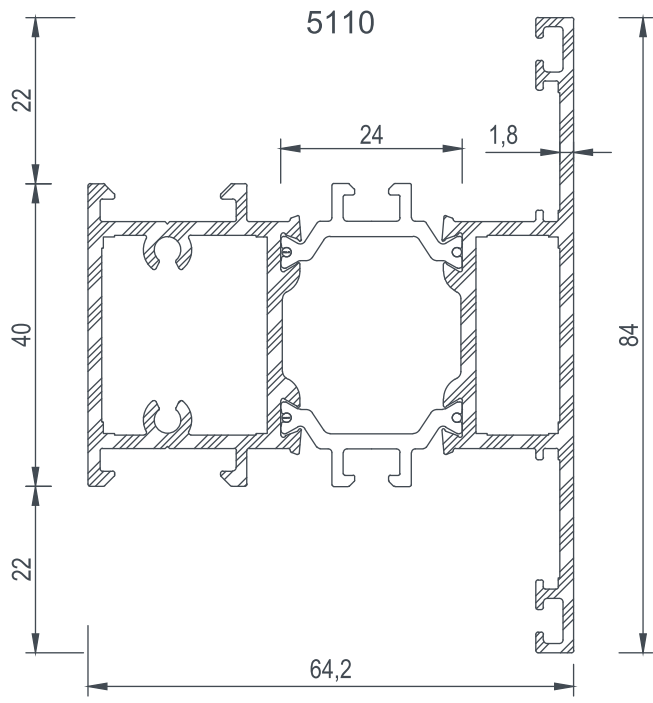
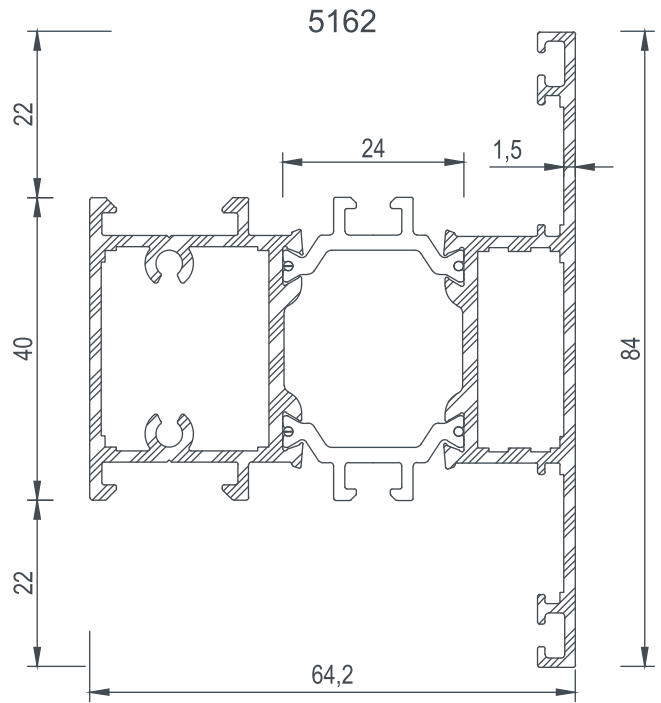
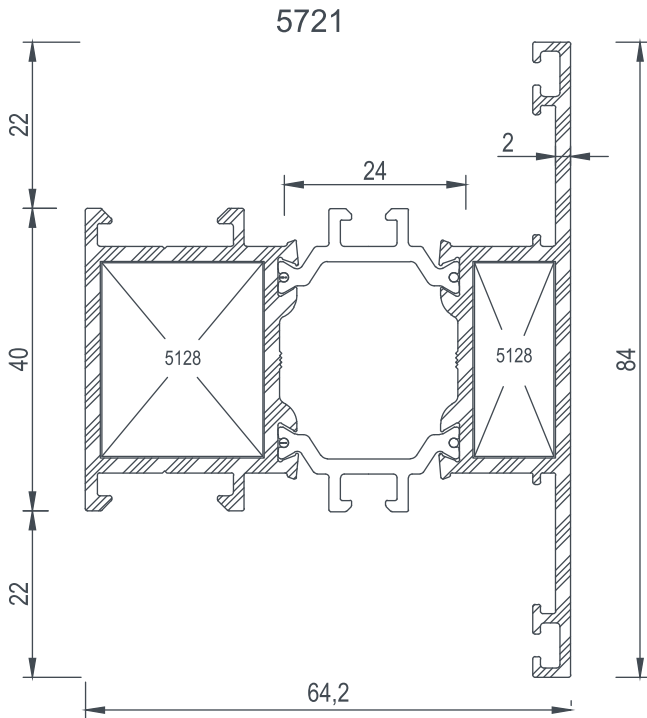



E 64

PROFİLLER / PROFILES

COD Code	AGIRLIK (kg/m) Weight	Jxx cm4	Jyy cm4	Wxx cm3	Wyy cm3	L m
5109	2,176	39,96	39,90	10,78	7,67	6
5163	2,268	89,26	26,66	15,14	6,34	6
5111	2,478	101,22	29,33	17,58	6,98	6

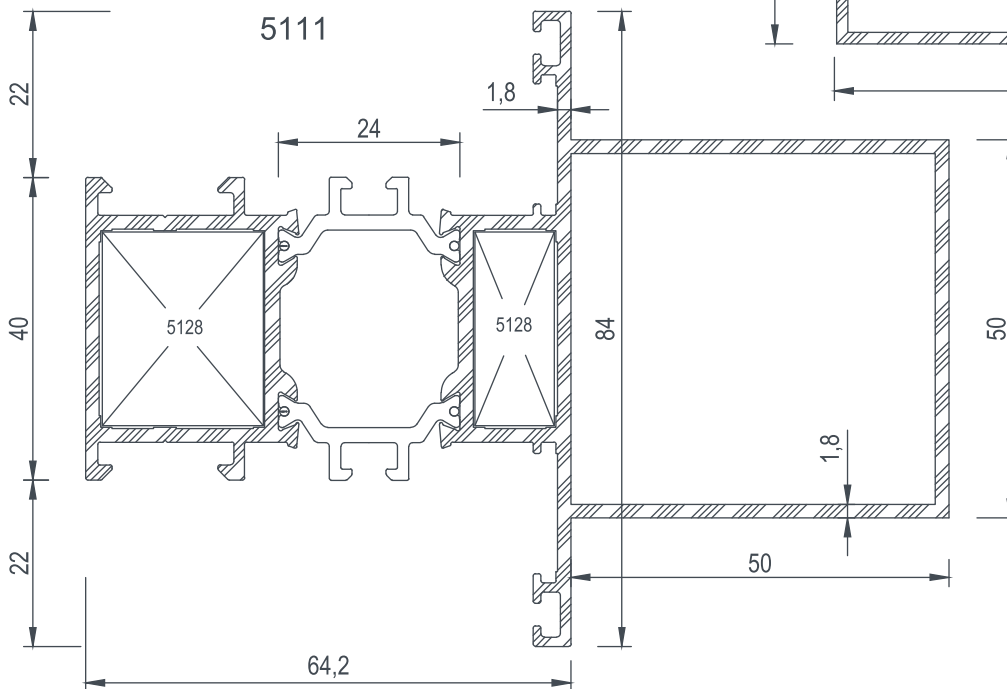
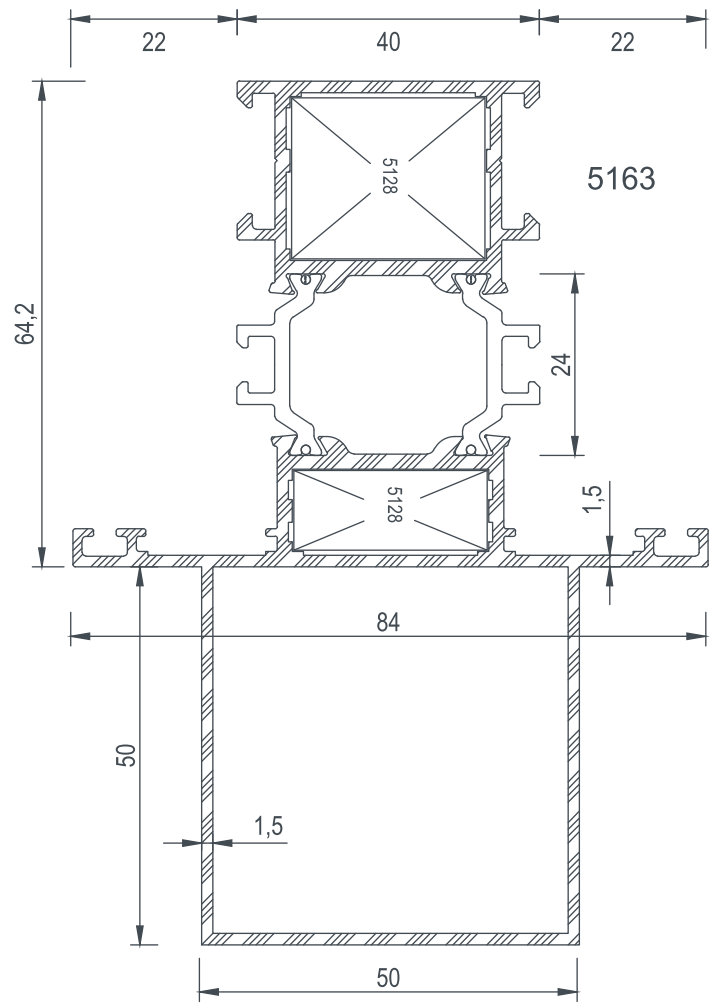
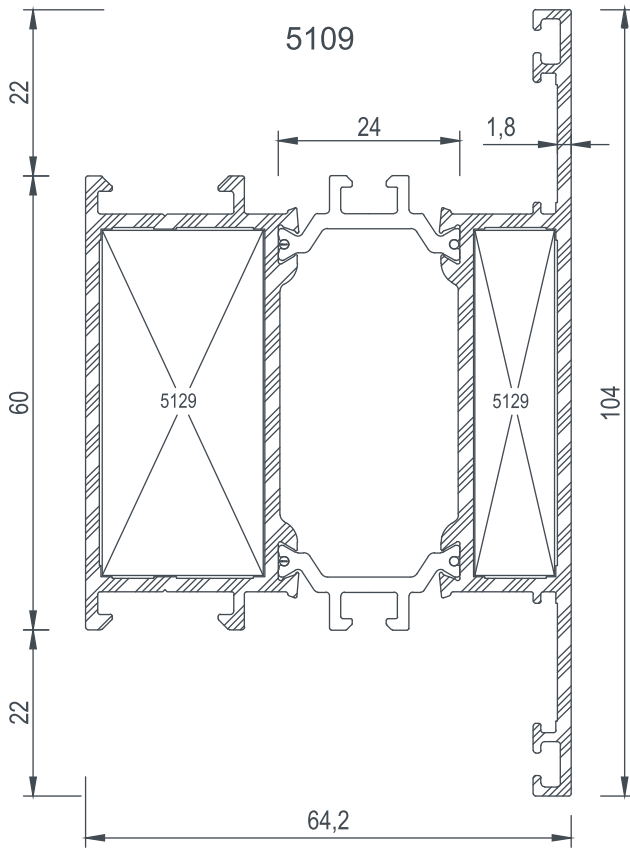



E 64

PROFİLLER / PROFILES

COD Code	AGIRLIK (kg/m) Weight	Jxx cm4	Jyy cm4	Wxx cm3	Wyy cm3	L m
5164	2,520	135,53	24,50	16,54	5,83	6
5112	2,680	149,56	26,77	18,49	6,37	6

5164

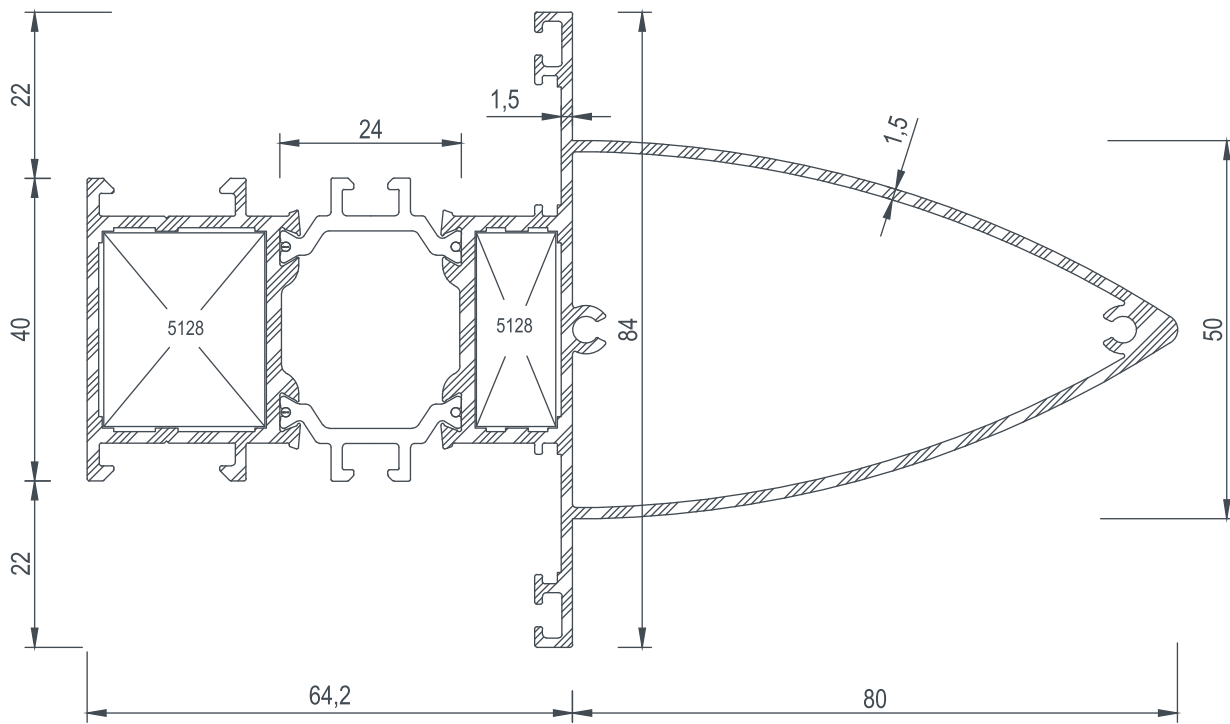

5112

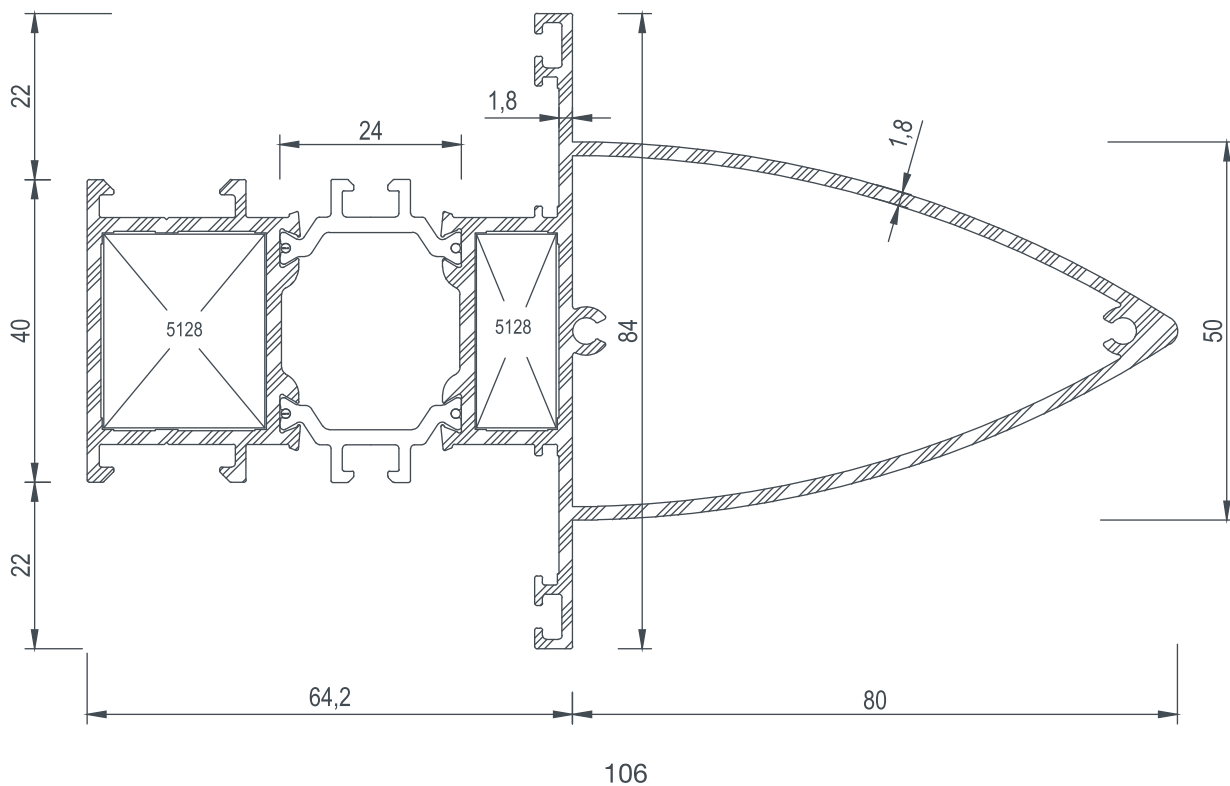



E 64

PROFİLLER / PROFILES

COD Code	AGIRLIK (kg/m) Weight	Jxx cm4	Jyy cm4	Wxx cm3	Wyy cm3	L m
5165	2,372	78,17	45,02	11,48	10,44	6
5113	2,563	85,90	50,78	12,55	11,70	6
5718	2,698	91,23	54,67	13,24	12,52	6

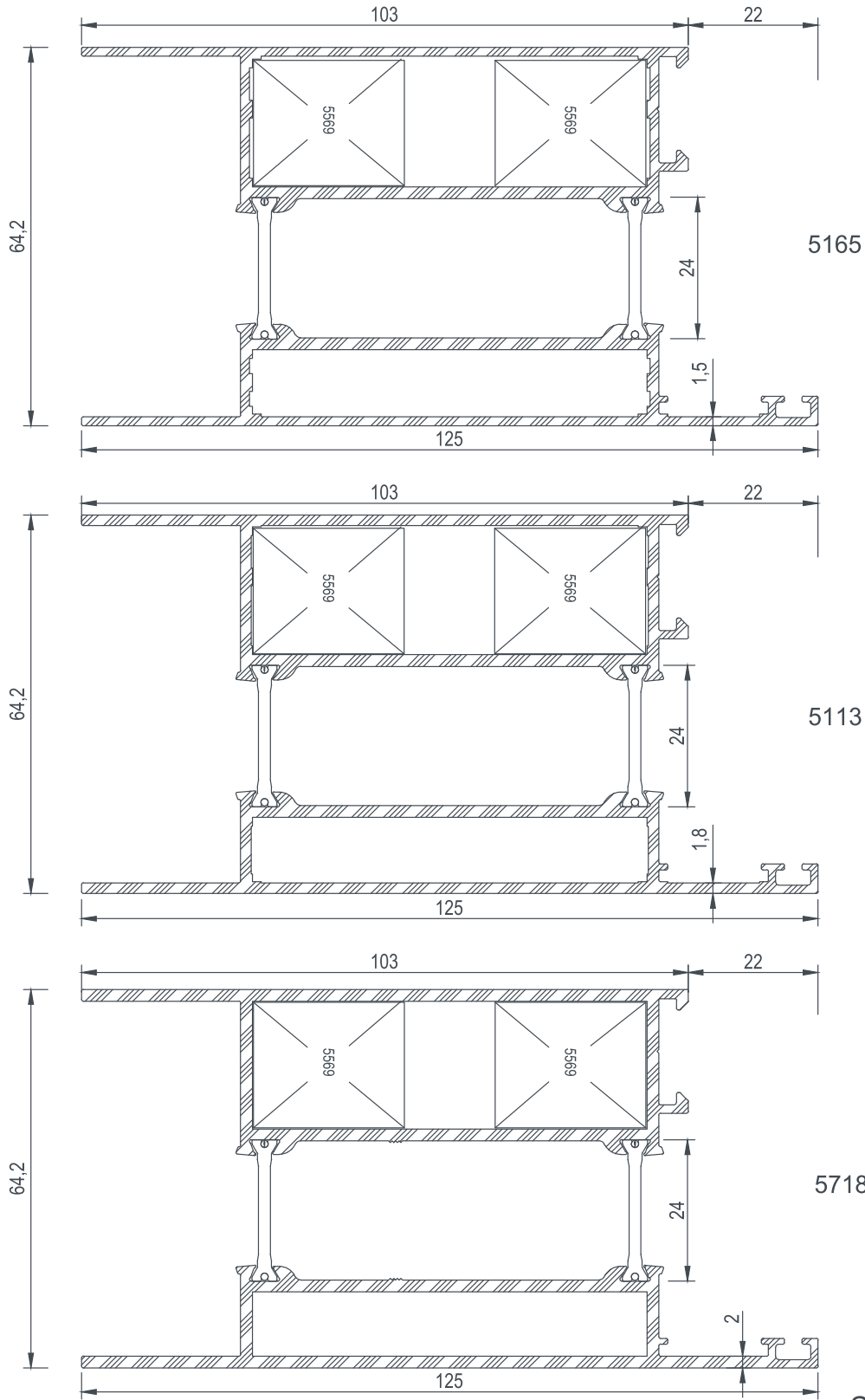

SCALE BY 1/10

107

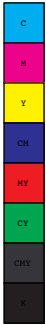



E 64

PROFİLLER / PROFILES

COD Code	AGIRLIK (kg/m) Weight	Jxx cm4	Jyy cm4	Wxx cm3	Wyy cm3	L m
5166	1,395	22,88	7,60	5,48	2,23	6
5167	1,410	24,98	9,22	6,29	2,91	6
5114	1,472	24,14	8,17	5,64	2,36	6
5115	1,519	27,47	10,27	6,94	3,34	6
5133	1,167	18,55	5,40	5,18	1,87	6

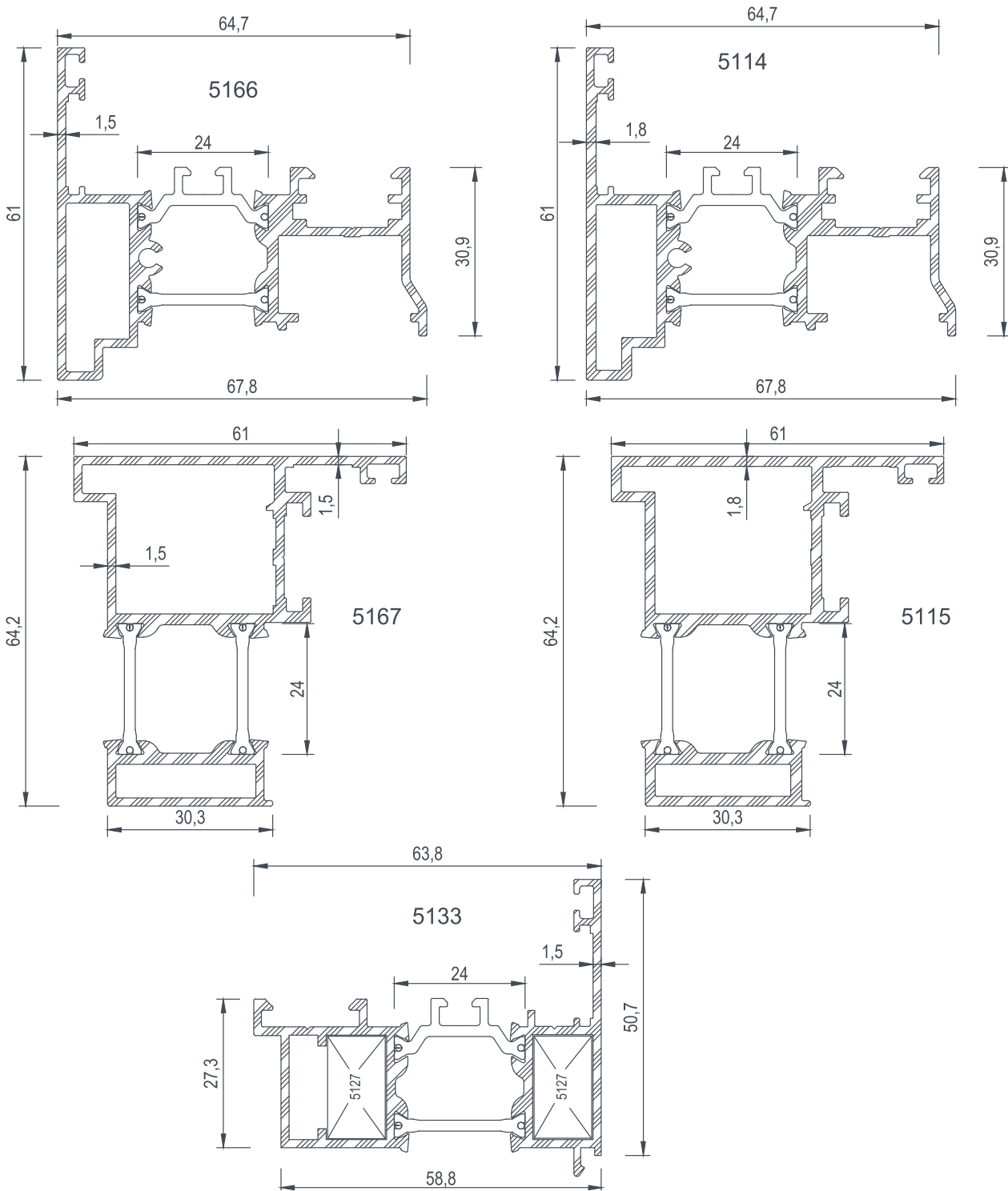

SCALE BY 1/10





E 64

PROFİLLER / PROFILES

COD Code	AGIRLIK (kg/m) Weight	Jxx cm4	Jyy cm4	Wxx cm3	Wyy cm3	L m
5116	2,045	45,84	40,77	8,61	7,78	6
5117	0,105	----	----	----	----	6
5134	1,349	17,31	15,15	5,41	4,91	6
5135	0,414	7,83	0,43	2,03	0,31	6
5136	0,291	2,35	0,11	0,84	0,14	6
5337	0,151	----	----	----	----	6
5572	0,100	----	----	----	----	6
5169	1,300	22,56	8,61	5,4	2,29	6

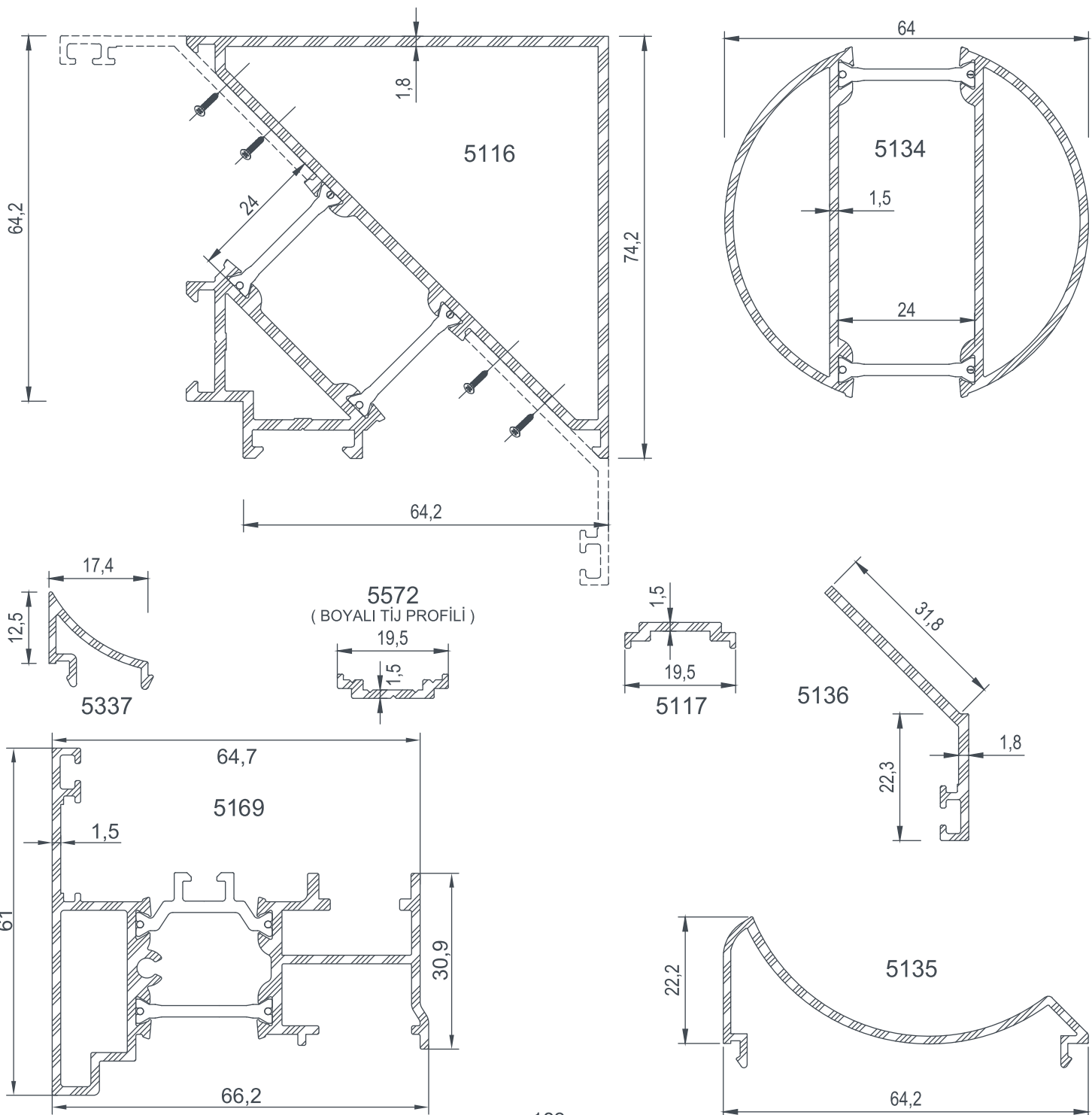



E 64

PROFİLLER / PROFILES

COD Code	AGIRLIK (kg/m) Weight	Jxx cm4	Jyy cm4	Wxx cm3	Wyy cm3	L m
5118	0,249	-----	-----	-----	-----	6
5119	0,251	-----	-----	-----	-----	6
5120	0,254	-----	-----	-----	-----	6
5121	0,259	-----	-----	-----	-----	6
5122	0,267	-----	-----	-----	-----	6
5123	0,274	-----	-----	-----	-----	6
5124	0,281	-----	-----	-----	-----	6
5125	0,292	-----	-----	-----	-----	6
5126	0,308	-----	-----	-----	-----	6
5535	0,305	-----	-----	-----	-----	6

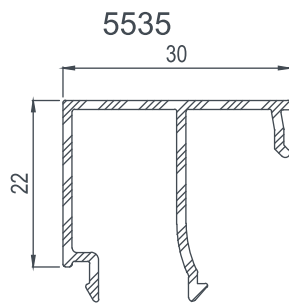
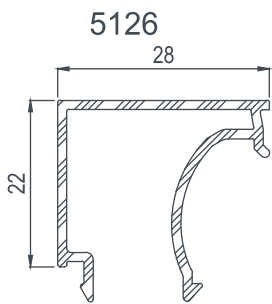
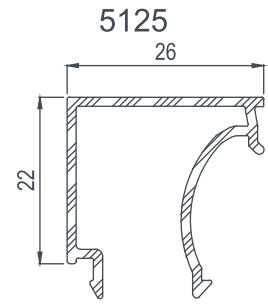
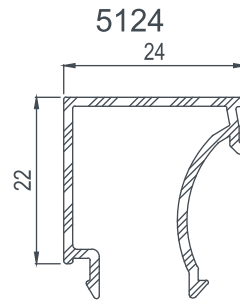
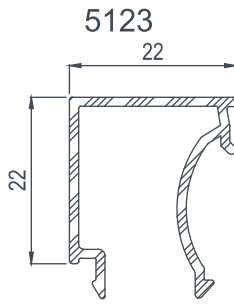
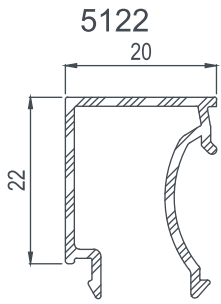
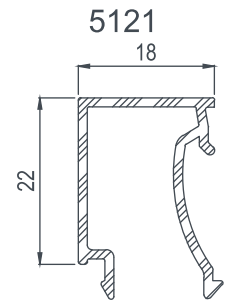
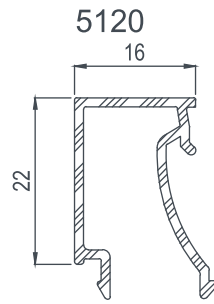
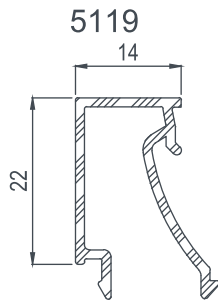
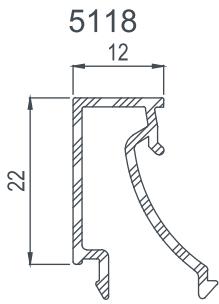

CAM ÇİTASI Glazing Bead	İÇ CAM FİTİLİ Glazing Gasket (in)	CAM KALINLIĞI Glas Thickness	DIŞ CAM FİTİLİ Glazing Gasket (out)
5118	E-01-027	40 mm	E-01-028
5119	E-01-027	38 mm	E-01-028
5120	E-01-027	36 mm	E-01-028
5121	E-01-027	34 mm	E-01-028
5122	E-01-027	32 mm	E-01-028
5123	E-01-027	30 mm	E-01-028
5124	E-01-027	28 mm	E-01-028
5125	E-01-027	26 mm	E-01-028
5126	E-01-027	24 mm	E-01-028
5535	E-01-027	22 mm	E-01-028



E 64

PROFİLLER / PROFILES

COD Code	AGIRLIK (kg/m) Weight	Jxx cm4	Jyy cm4	Wxx cm3	Wyy cm3	L m
5536	0,312	-----	-----	-----	-----	6
5537	0,318	-----	-----	-----	-----	6
5538	0,325	-----	-----	-----	-----	6
5539	0,331	-----	-----	-----	-----	6

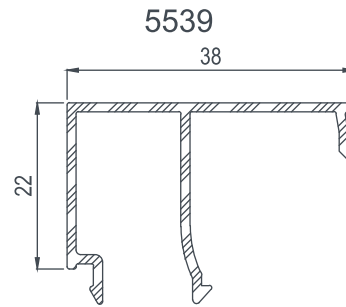
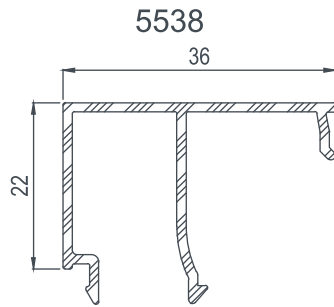
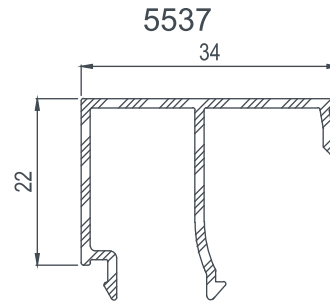
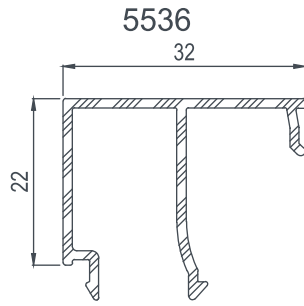

CAM ÇİTASI Glazing Bead	İÇ CAM FİTİLİ Glazing Gasket (in)	CAM KALINLIĞI Glas Thickness	DIŞ CAM FİTİLİ Glazing Gasket (out)
5536	E-01-027	20 mm	E-01-028
5537	E-01-027	18 mm	E-01-028
5538	E-01-027	16 mm	E-01-028
5539	E-01-027	14 mm	E-01-028



clarks

E 64

PROFİLLER

PROFILES

E 64 - 2.0T GİZLİ KANAT PROFİLİ
E 64 - 2.0T SECRET SASH PROFILE





E 64

PROFİLLER / PROFILES

COD Code	AGIRLIK (kg/m) Weight	Jxx cm4	Jyy cm4	Wxx cm3	Wyy cm3	L m
5170	2,175	72,89	39,20	9,78	9,09	6
5171	1,990	49,54	29,62	7,20	6,32	6

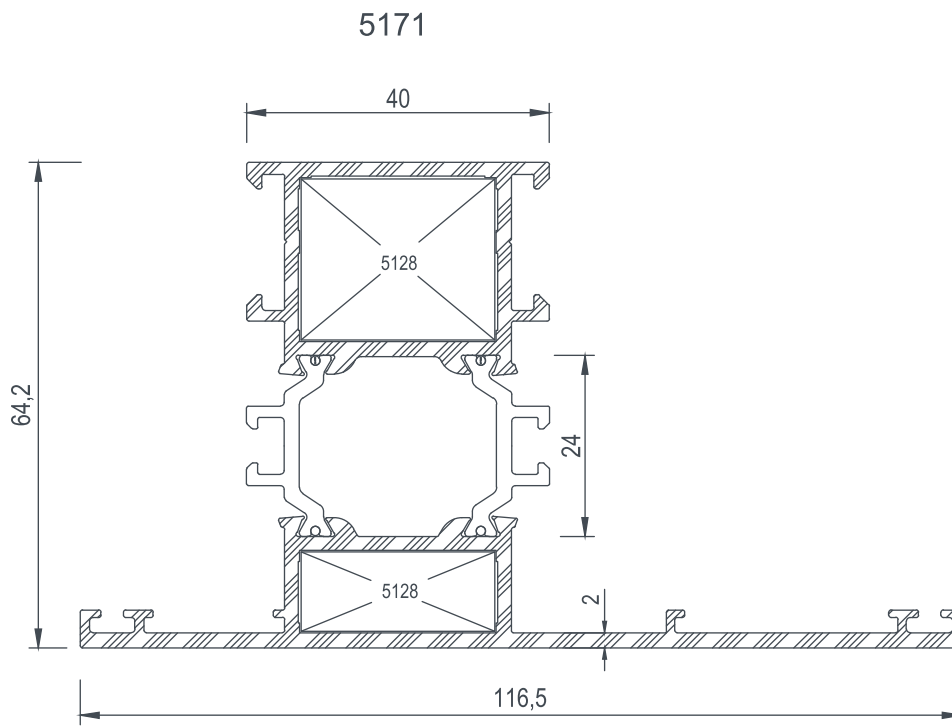
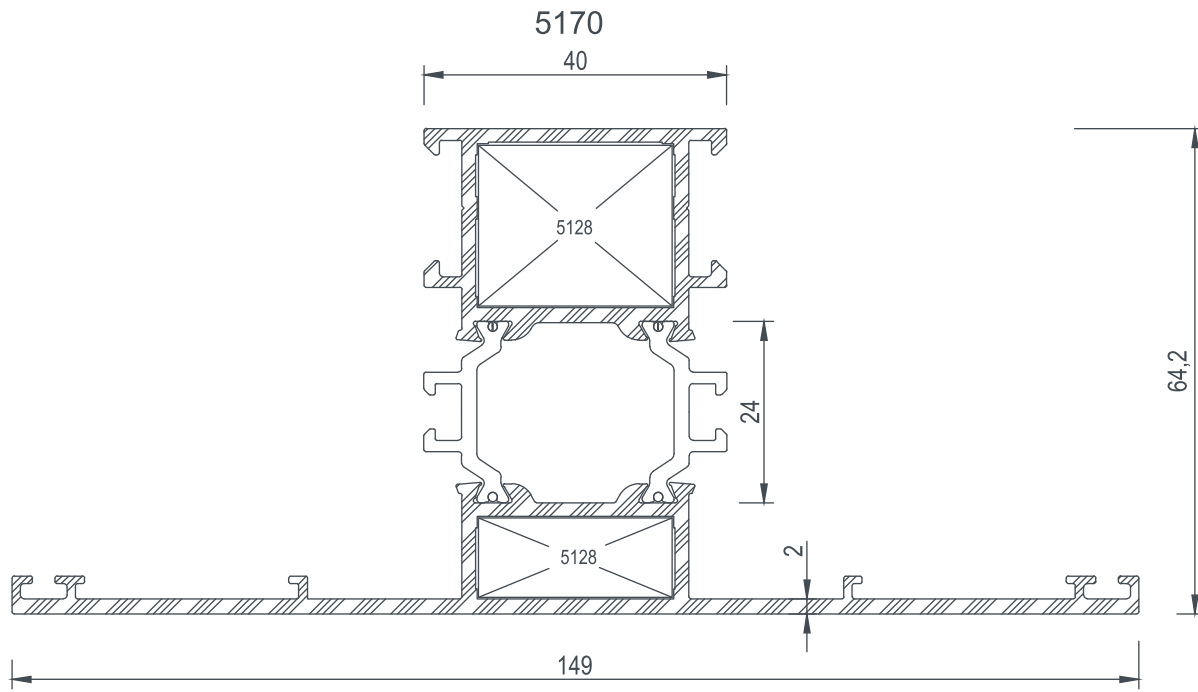

115





E 64

PROFİLLER / PROFILES

COD Code	AGIRLIK (kg/m) Weight	Jxx cm ⁴	Jyy cm ⁴	Wxx cm ³	Wyy cm ³	L m
5172	1,796	47,90	19,04	7,58	4,86	6
5173	1,450	29,22	5,65	7,08	2,33	6

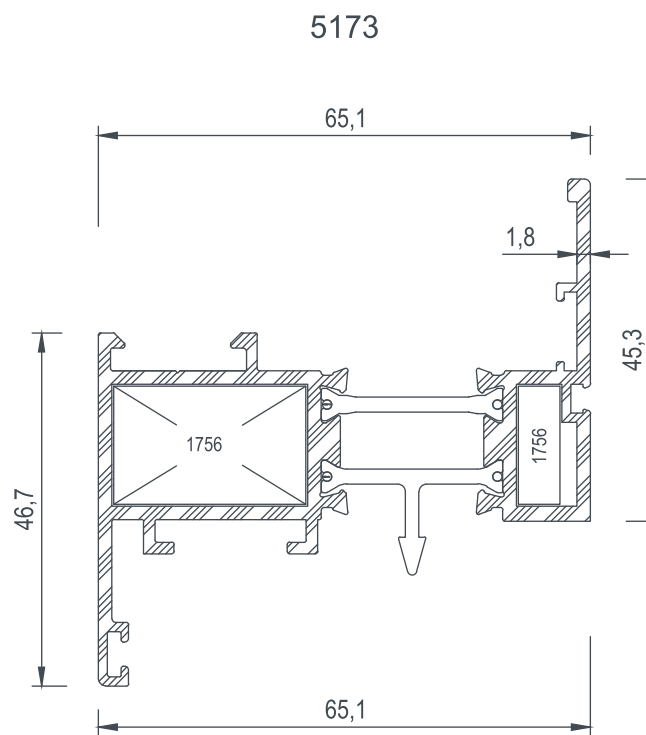
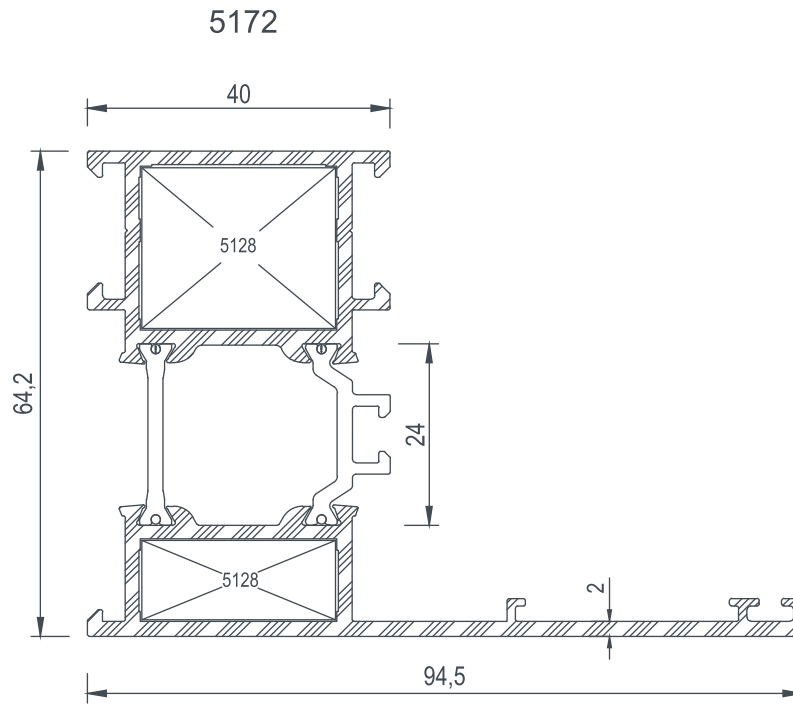



E 64

PROFİLLER / PROFILES

COD Code	AGIRLIK (kg/m) Weight	Jxx cm ⁴	Jyy cm ⁴	Wxx cm ³	Wyy cm ³	L m
5587	0,510	6,36	0,82	1,97	0,75	6
5588	0,521	6,63	1,05	2,00	0,90	6
5589	0,548	7,30	1,18	2,11	0,73	6
5590	0,542	7,13	1,08	2,08	0,73	6
5591	0,534	6,97	1,00	2,06	0,74	6

5587

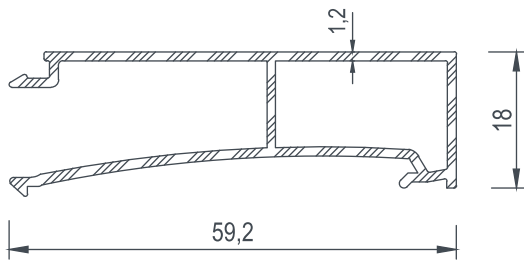

5588

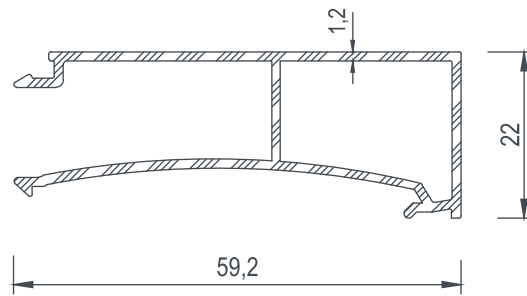

5589

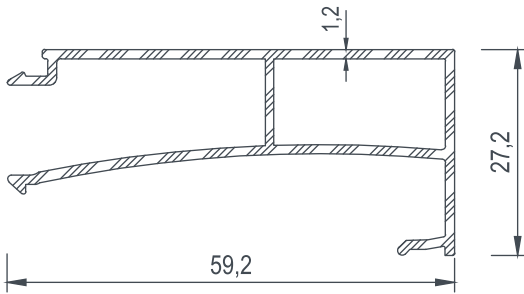

5590

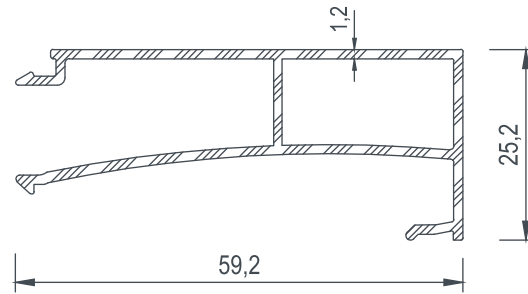

5591

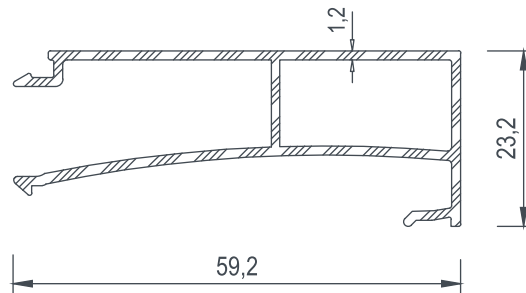



E 64

PROFİLLER / PROFILES

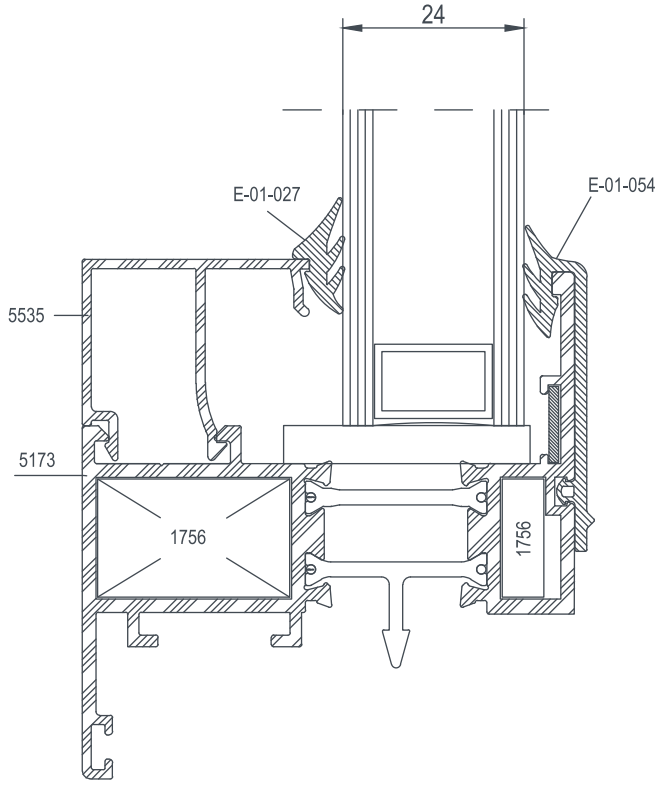

CAM ÇİTASI Glazing Bead	İÇ CAM FİTİLİ Glazing Gasket (in)	CAM KALINLIĞI Glas Thickness	DIŞ CAM FİTİLİ Glazing Gasket (out)
5535	E-01-027	24 mm	E-01-054
5126	E-01-027	26 mm	E-01-054
5125	E-01-027	28 mm	E-01-054
5124	E-01-027	30 mm	E-01-054
5123	E-01-027	32 mm	E-01-054
5122	E-01-027	34 mm	E-01-054
5121	E-01-027	36 mm	E-01-054
5120	E-01-027	38 mm	E-01-054
5119	E-01-027	40 mm	E-01-054
5118	E-01-027	42 mm	E-01-054

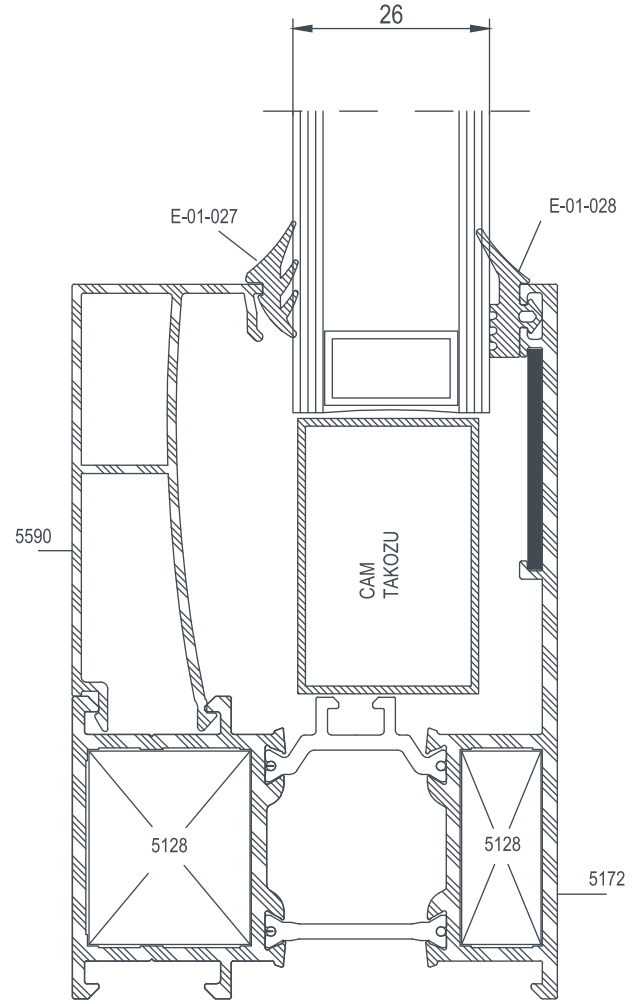

CAM ÇİTASI Glazing Bead	İÇ CAM FİTİLİ Glazing Gasket (in)	CAM KALINLIĞI Glas Thickness	DIŞ CAM FİTİLİ Glazing Gasket (out)
5589	E-01-027	24 mm	E-01-028
5590	E-01-027	26 mm	E-01-028
5591	E-01-027	28 mm	E-01-028
5588	E-01-027	30 mm	E-01-028
5587	E-01-027	32 mm	E-01-028



E 64

PROFİLLER / PROFILES

COD Code	AGIRLIK (kg/m) Weight	Jxx cm4	Jyy cm4	Wxx cm3	Wyy cm3	L m
1756	2,474	---	---	---	---	6
1885	4,471	---	---	---	---	6
4550	3,581	---	---	---	---	6

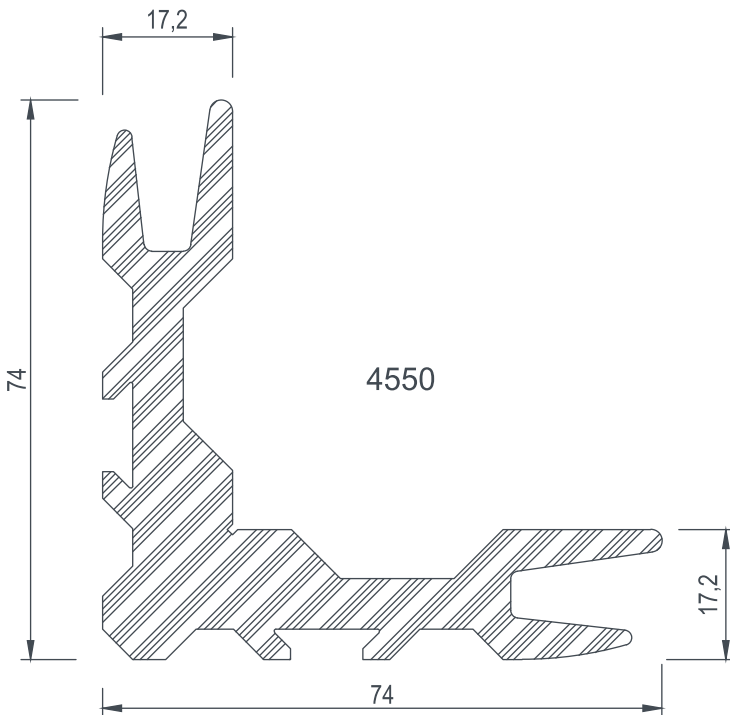
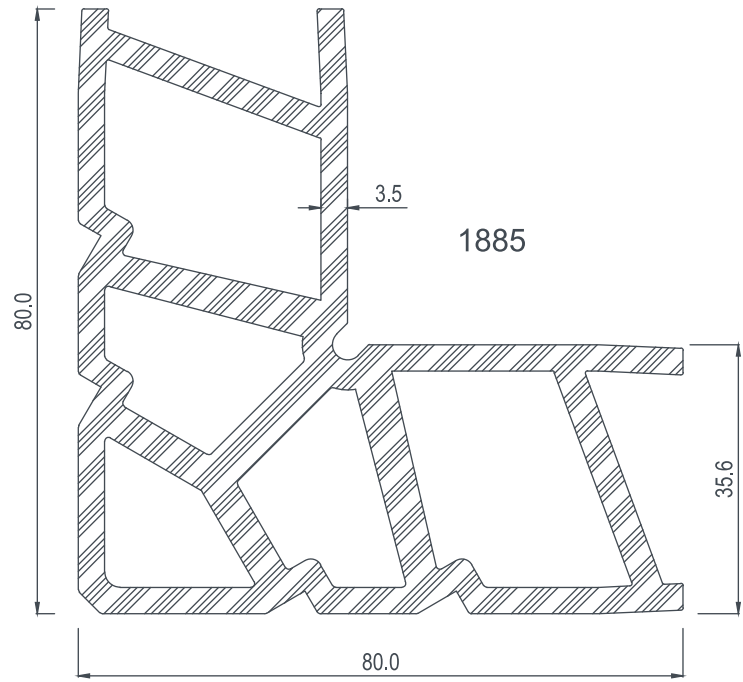
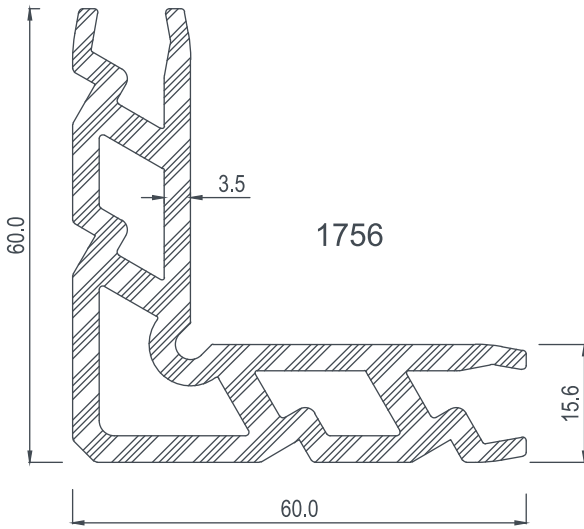

KÖŞE TAKOZLARI / Corner Cleats

Nr	L m	AKS. KODU Acs. Code	KESİM ÖLÇÜSÜ Cutting Size
5155	1756	1756-26,8	26,8 mm
	1756	1756-5,4	5,4 mm
5173	1756	1756-25,4	25,4 mm
	1756	1756-5,5	5,5 mm
5156	1885	1885-18,3	18,3 mm
	1885	1885-5,3	5,3 mm
5722	4550	4550-18,3	18,3 mm
	4550	4550-5,3	5,3 mm



E 64

PROFİLLER / PROFILES

COD Code	AGIRLIK (kg/m) Weight	Jxx cm4	Jyy cm4	Wxx cm3	Wyy cm3	L m
5127	3,484	---	---	---	---	6

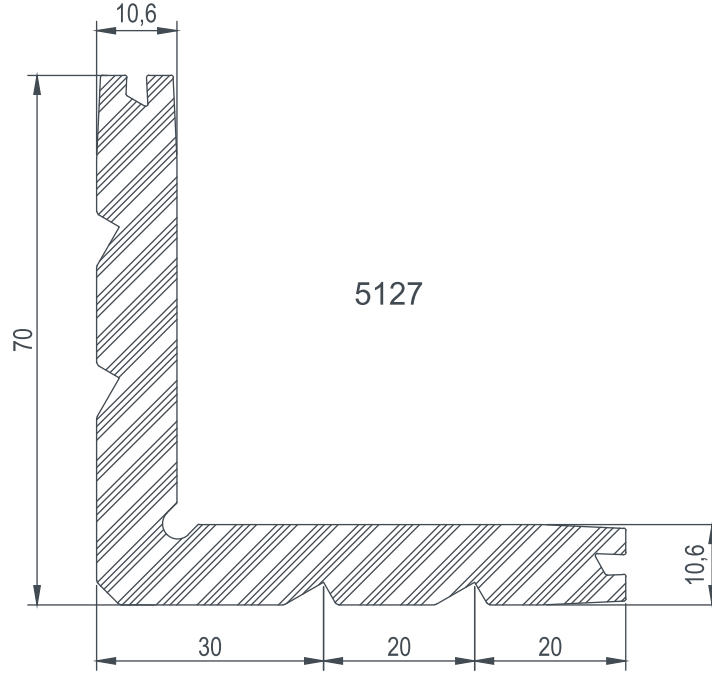

KÖŞE TAKOZLARI / Corner Cleats

Nr	 L m	AKS. KODU Ac. Code	KESİM ÖLÇÜSÜ Cutting Size
5100	5127	5127-21,3	21,3 mm
	5127	5127-10,5	10,5 mm
5103	5127	5127-18,6	18,6 mm
	5127	5127- 5,3	5,3 mm
5107	5127	5127-21,3	21,3 mm
	5127	5127-10,5	10,5 mm
5159	5127	5127-21,3	21,3 mm
	5127	5127-10,5	10,5 mm
5153	5127	5127-18,6	18,6 mm
	5127	5127- 5,3	5,3 mm
5150	5127	5127-21,3	21,3 mm
	5127	5127-10,5	10,5 mm
5133	5127	5127-18,77	18,77 mm
	5127	5127-18,77	18,77 mm



E 64

PROFİLLER / PROFILES

COD Code	AGIRLIK (kg/m) Weight	Jxx cm4	Jyy cm4	Wxx cm3	Wyy cm3	L m
5128	3,652	---	---	---	---	6

KÖŞE TAKOZLARI / Corner Cleats

Nr	 L m	AKS. KODU Acs. Code	KESİM ÖLÇÜSÜ Cutting Size
5101	5128	5128-21,3	21,3 mm
	5128	5128-10,5	10,5 mm
5104	5128	5128-18,6	18,6 mm
	5128	5128-5,3	5,3 mm
5108	5128	5128-21,3	21,3 mm
	5128	5128-10,5	10,5 mm
5111	5128	5128-21,3	21,3 mm
	5128	5128-10,5	10,5 mm
5112	5128	5128-21,3	21,3 mm
	5128	5128-10,5	10,5 mm
5151	5128	5128-21,3	21,3 mm
	5128	5128-10,5	10,5 mm
5154	5128	5128-18,6	18,6 mm
	5128	5128-5,3	5,3 mm
5160	5128	5128-21,3	21,3 mm
	5128	5128-10,5	10,5 mm
5163	5128	5128-21,3	21,3 mm
	5128	5128-10,5	10,5 mm
5164	5128	5128-21,3	21,3 mm
	5128	5128-10,5	10,5 mm
5137	5128	5128-18,3	18,3 mm
	5128	5128-5,4	5,4 mm
5140	5128	5128-21,3	21,3 mm
	5128	5128-10,5	10,5 mm
5147	5128	5128-21,3	21,3 mm
	5128	5128-10,5	10,5 mm
5719	5128	5128-18,6	18,6 mm
	5128	5128-5,3	5,3 mm
5721	5128	5128-21,3	21,3 mm
	5128	5128-10,5	10,5 mm
5170	5128	5128-21,3	21,3 mm
	5128	5128-10,5	10,5 mm
5171	5128	5128-21,3	21,3 mm
	5128	5128-10,5	10,5 mm
5172	5128	5128-21,3	21,3 mm
	5128	5128-10,5	10,5 mm

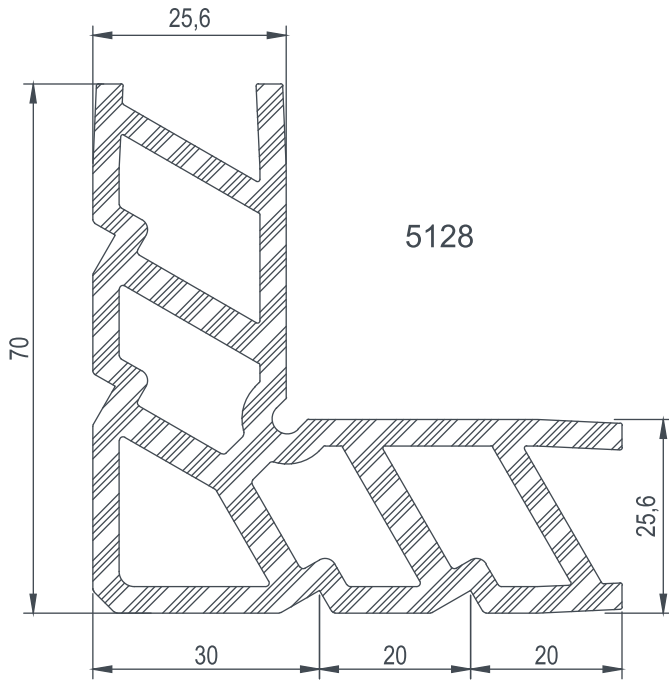



E 64

PROFİLLER / PROFILES

COD Code	AGIRLIK (kg/m) Weight	Jxx cm4	Jyy cm4	Wxx cm3	Wyy cm3	L m
5129	4,618	----	----	----	----	6

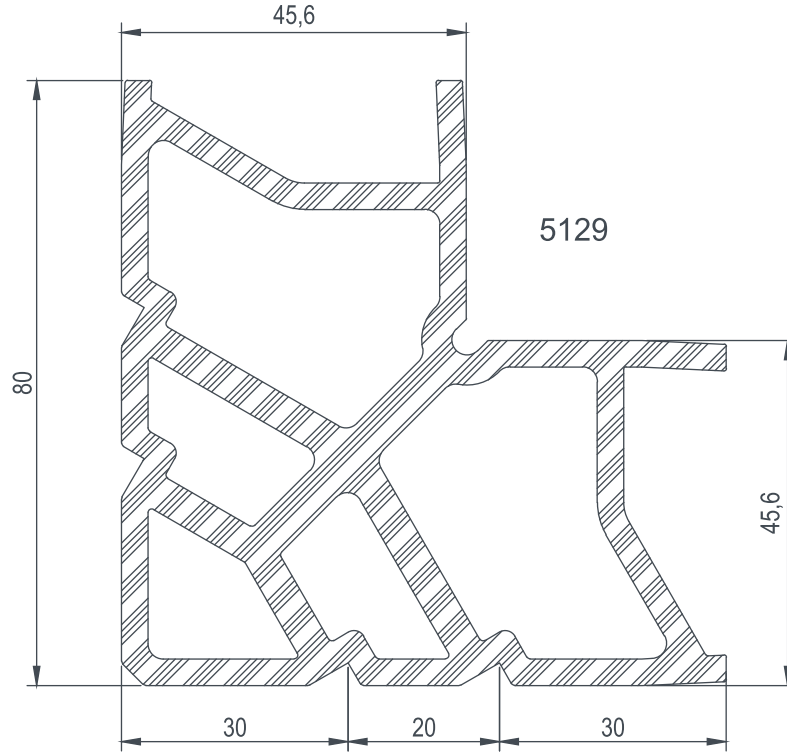

KÖŞE TAKOZLARI / Corner Cleats

Nr	 L m	AKS. KODU Acs. Code	KESİM ÖLÇÜSÜ Cutting Size
5102	5129	5129-21,3	21,3 mm
	5129	5129-10,5	10,5 mm
5106	5129	5129-26,7	26,7 mm
	5129	5129-5,3	5,3 mm
5109	5129	5129-21,3	21,3 mm
	5129	5129-10,5	10,5 mm
5152	5129	5129-21,3	21,3 mm
	5129	5129-10,5	10,5 mm
5158	5129	5129-26,7	26,7 mm
	5129	5129-5,3	5,3 mm
5161	5129	5129-21,3	21,3 mm
	5129	5129-10,5	10,5 mm
5138	5129	5129-18,3	18,3 mm
	5129	5129-5,4	5,4 mm
5141	5129	5129-21,3	21,3 mm
	5129	5129-10,5	10,5 mm



E 64

PROFİLLER / PROFILES

COD Code	AGIRLIK (kg/m) Weight	Jxx cm4	Jyy cm4	Wxx cm3	Wyy cm3	L m
4542	5,381	---	---	---	---	6

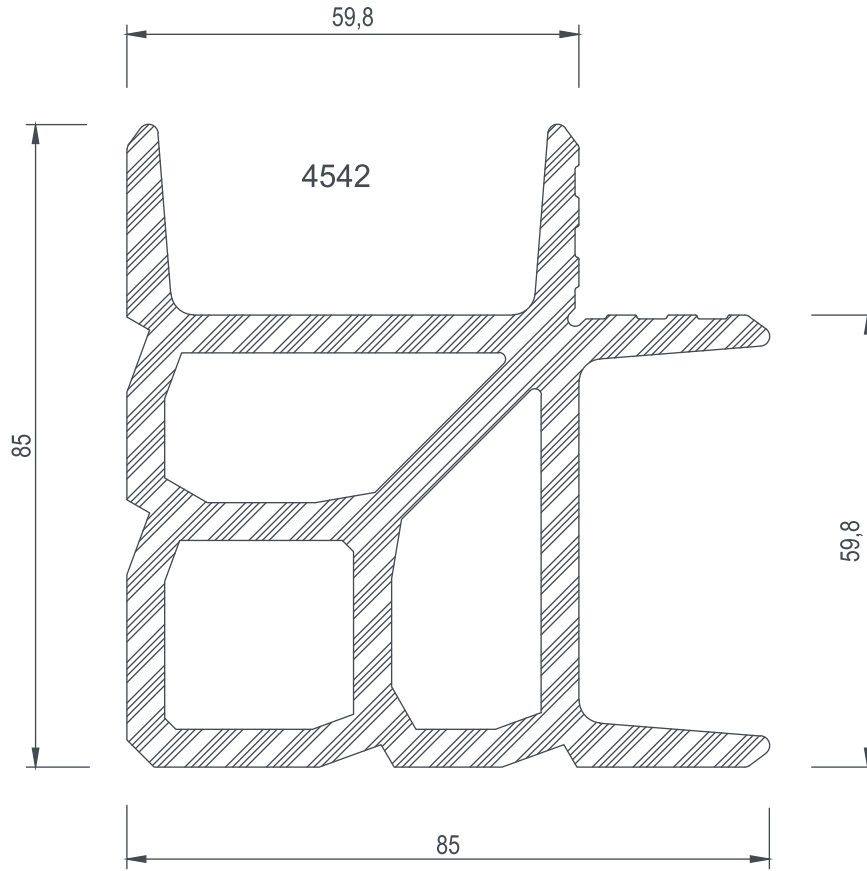

KÖŞE TAKOZLARI / Corner Cleats

Nr	AKS. KODU Acs. Code	KESİM ÖLÇÜSÜ Cutting Size
5157	4542-18,6	18,6 mm
	4542-5,3	5,3 mm
5139	4542-18,6	18,6 mm
	4542-5,3	5,3 mm
5720	4542-18,6	18,6 mm
	4542-5,3	5,3 mm



E 64

PROFİLLER / PROFILES

COD Code	AGIRLIK (kg/m) Weight	Jxx cm4	Jyy cm4	Wxx cm3	Wyy cm3	L m ←→
5569	0,555	---	---	---	---	6
5570	0,393	---	---	---	---	6
5571	0,772	---	---	---	---	6

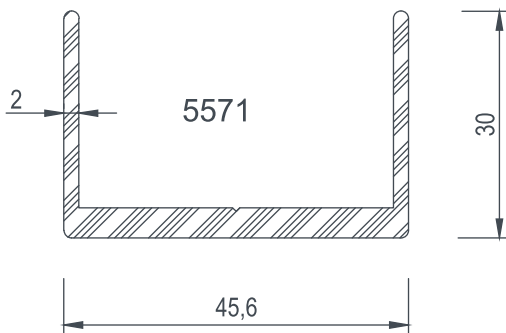
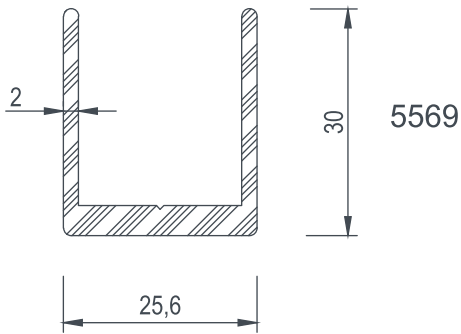
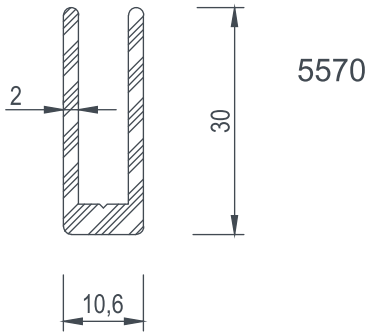

ORTA KAYIT BAĞLANTI / Mullion Connection Piece

Nr	 ←→ L m	 AKS. KODU Acs. Code	KESİM ÖLÇÜSÜ Cutting Size
5107	5570	5570-21,3	21,3 mm
5108	5569	5569-21,3	21,3 mm
5109	5571	5571-45,6	45,6 mm
5110	----	----	----
5111	5569	5569-21,3	21,3 mm
5112	5569	5569-21,3	21,3 mm
5113	5569	5569-21,3	21,3 mm
5159	5570	5570-21,3	21,3 mm
5160	5569	5569-21,3	21,3 mm
5161	5571	5571-45,6	45,6 mm
5162	----	----	----
5163	5569	5569-21,3	21,3 mm
5164	5569	5569-21,3	21,3 mm
5165	5569	5569-21,3	21,3 mm
5113	5569	5569-21,3	21,3 mm
5718	5569	5569-21,3	21,3 mm

clarks

E 64

DETAYLAR
DETAILS







E 64

DEAYLAR / DETAILS

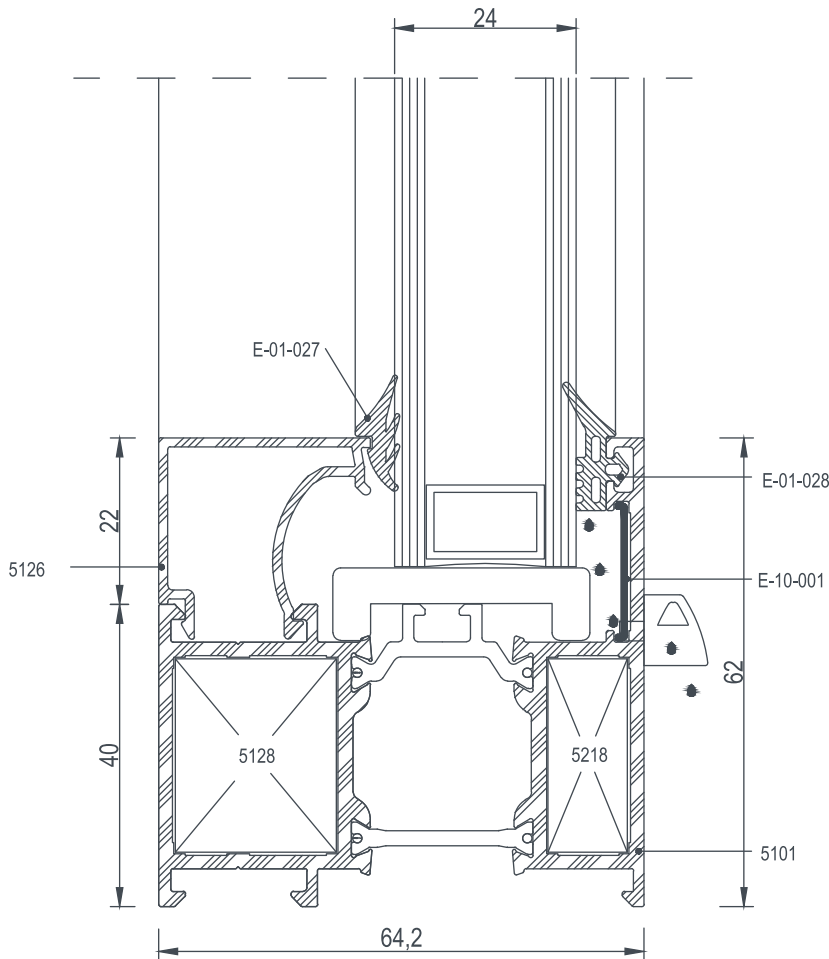
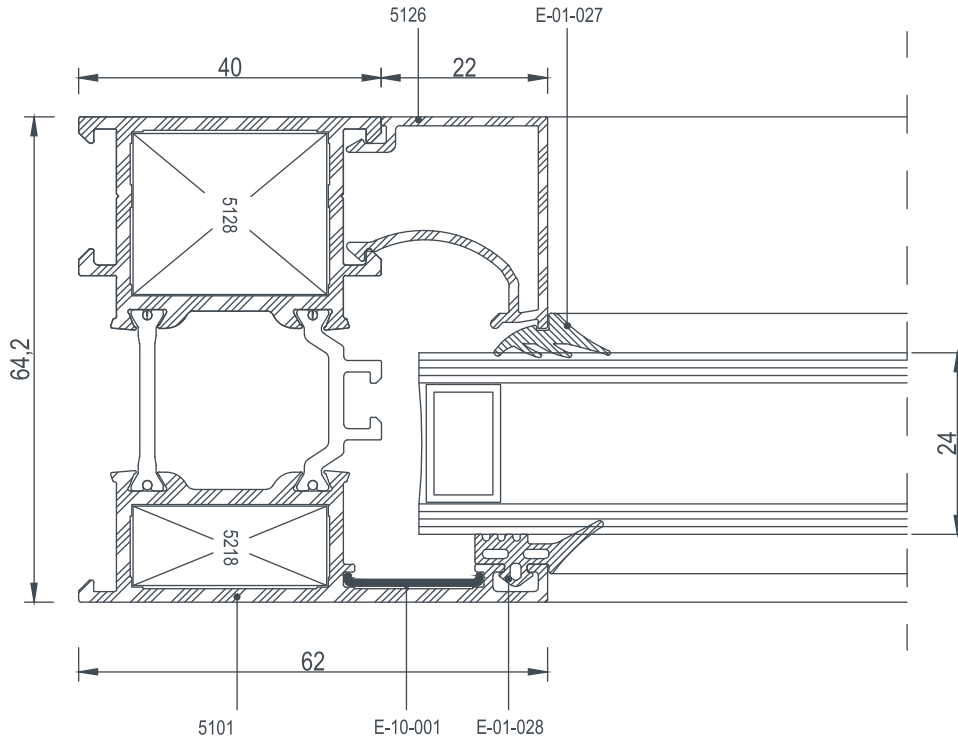



E 64

DETAYLAR / DETAILS

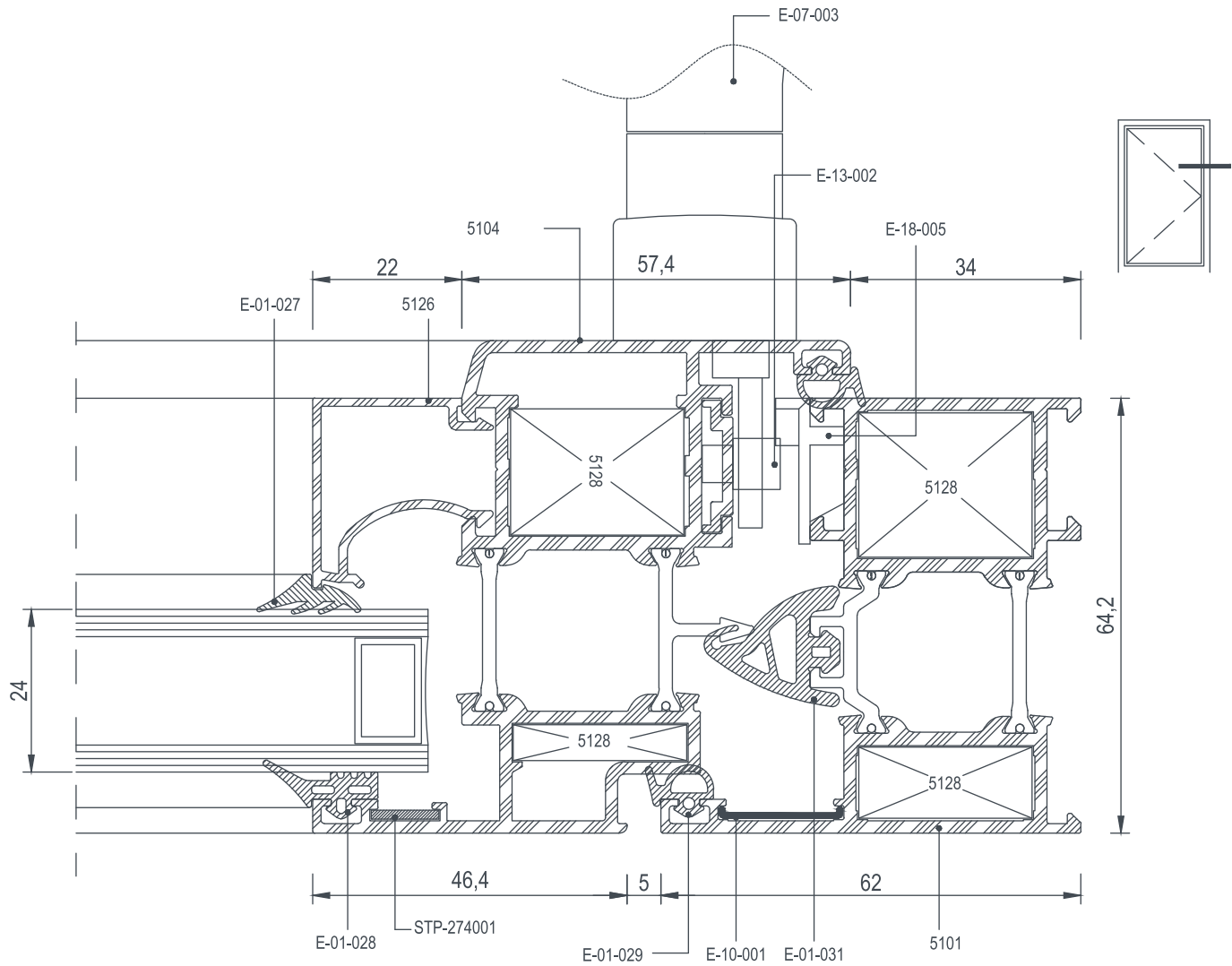
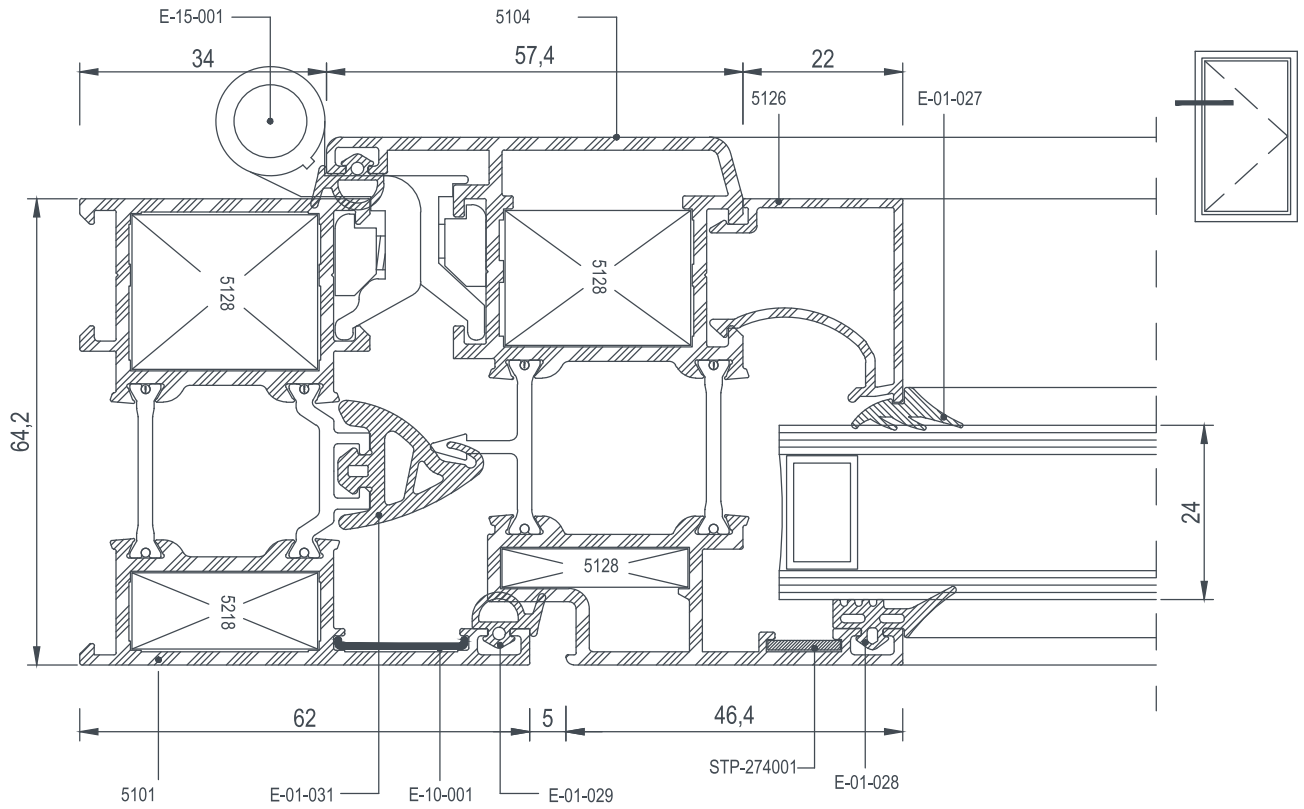



E 64

DEAYLAR / DETAILS

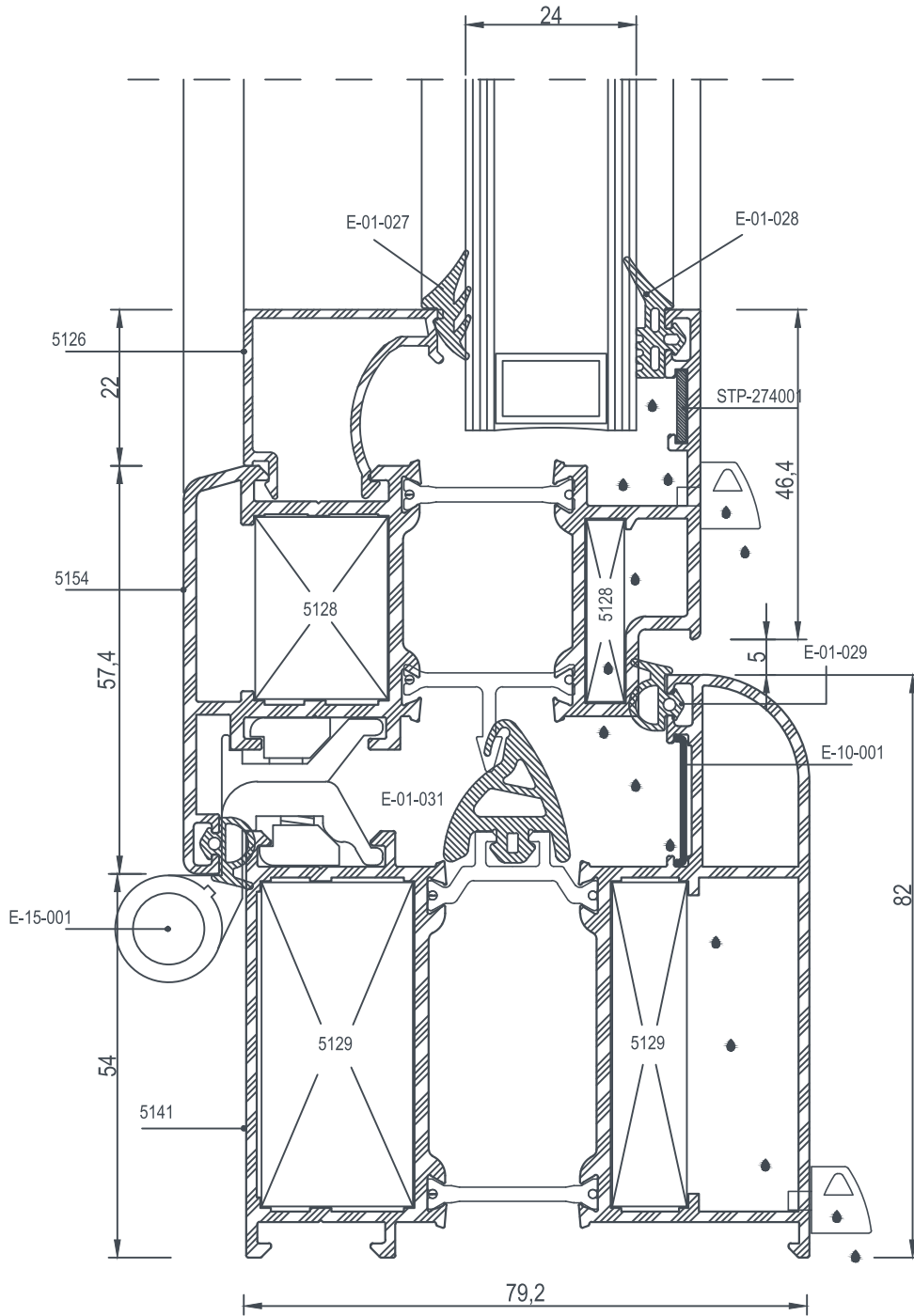



E 64

DEAYLAR / DETAILS

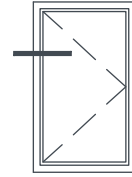
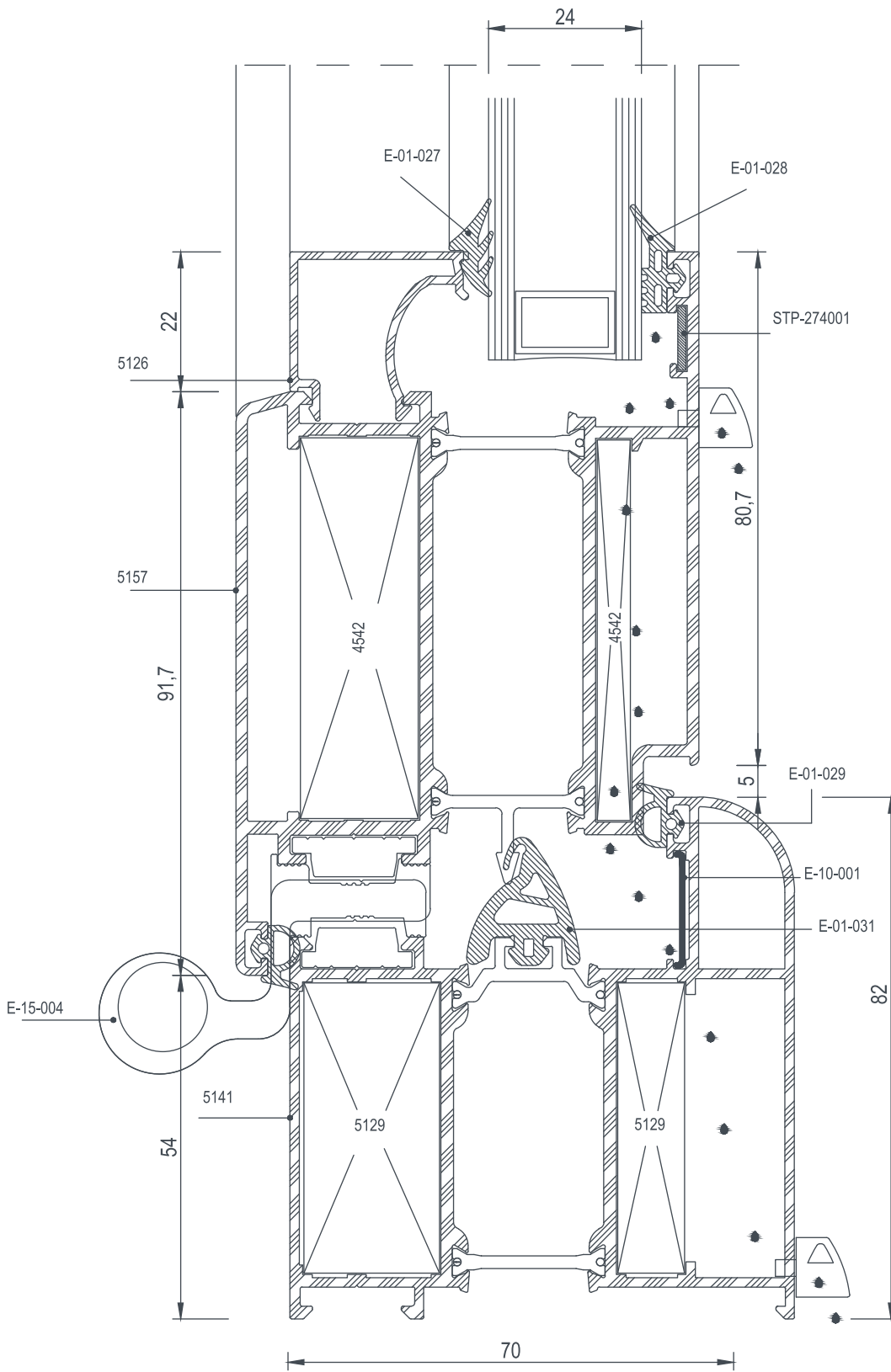



E 64

DEAYLAR / DETAILS

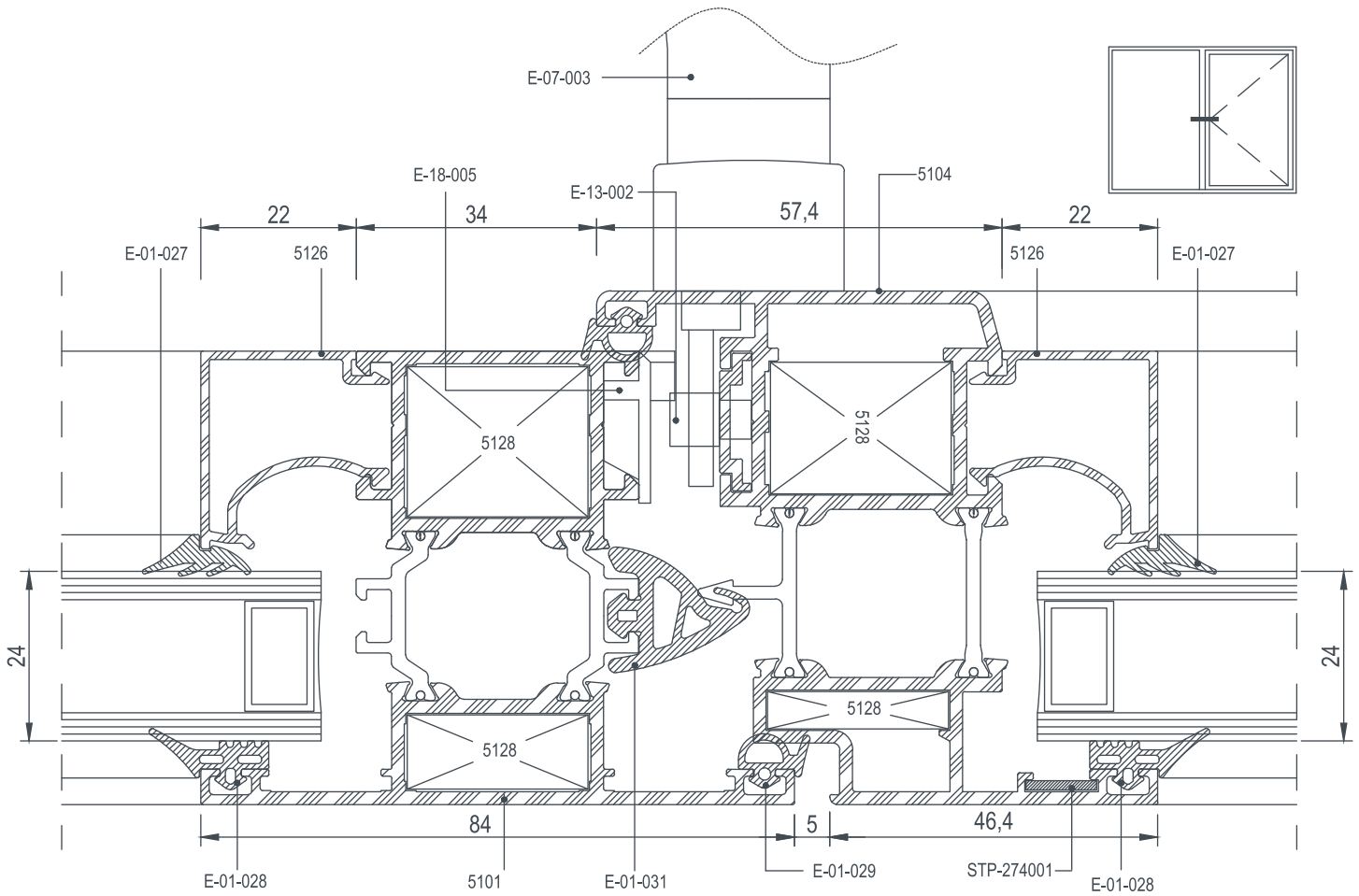
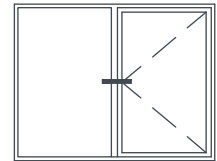
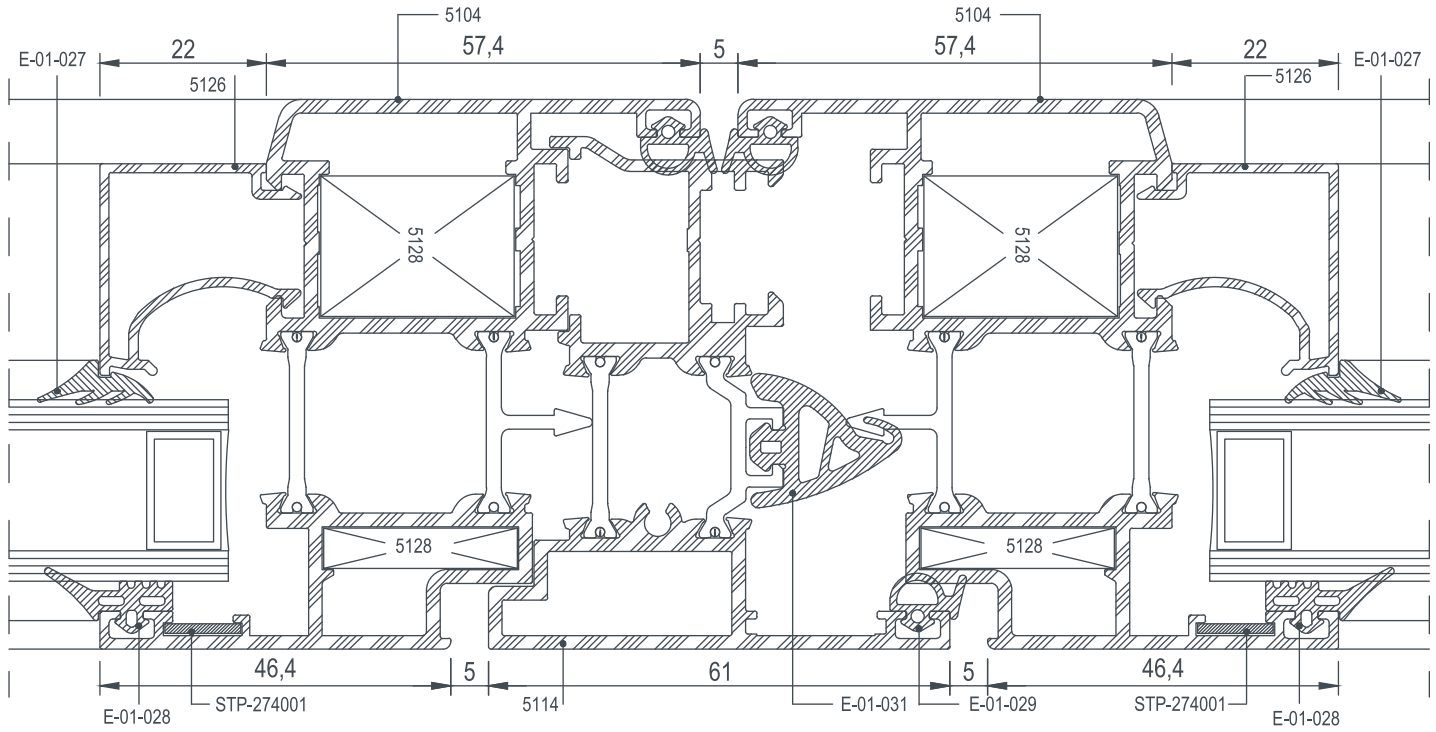
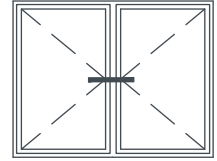



E 64

DEYAYLAR / DETAILS

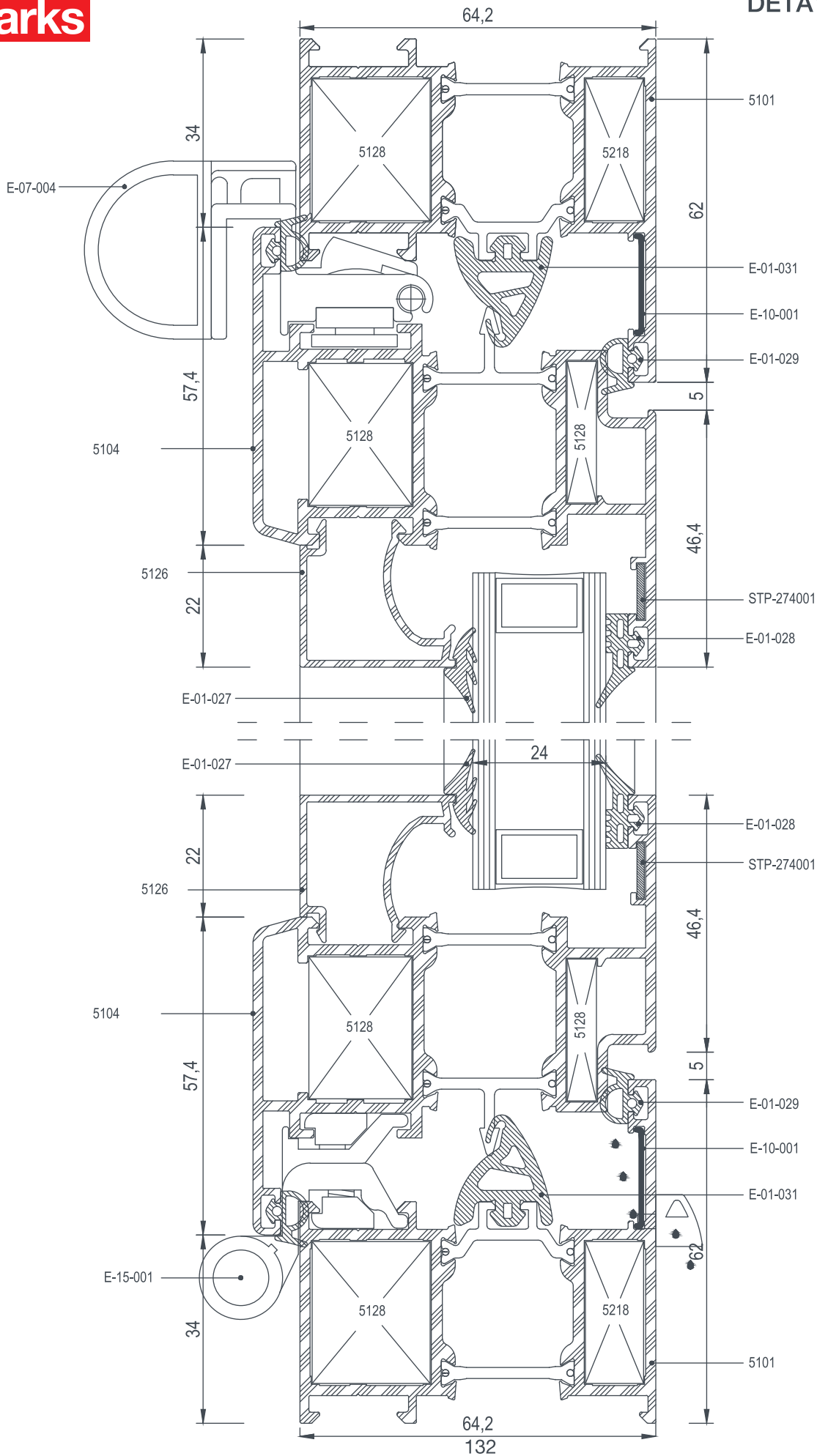



E 64

DETAYLAR / DETAILS

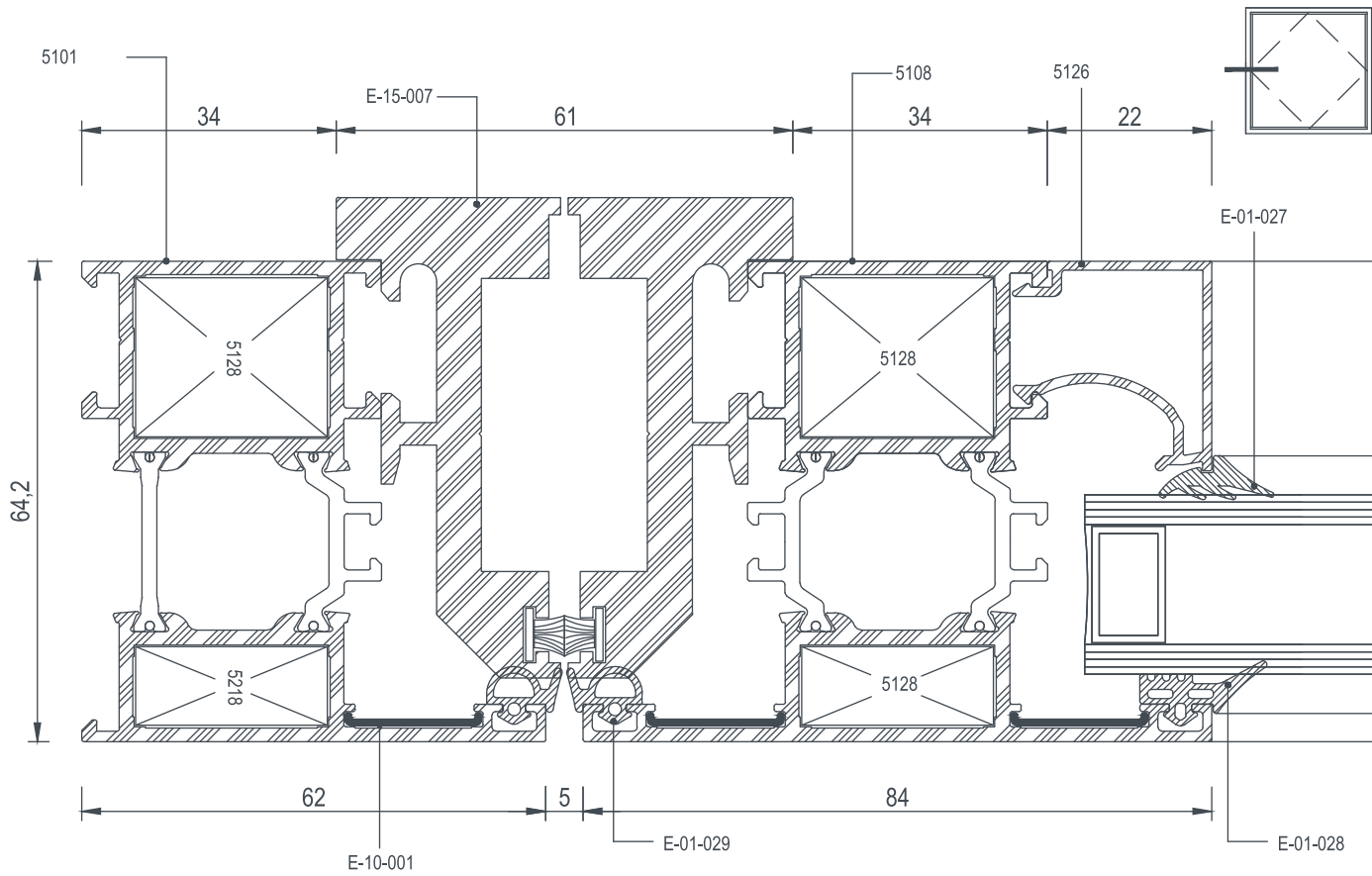
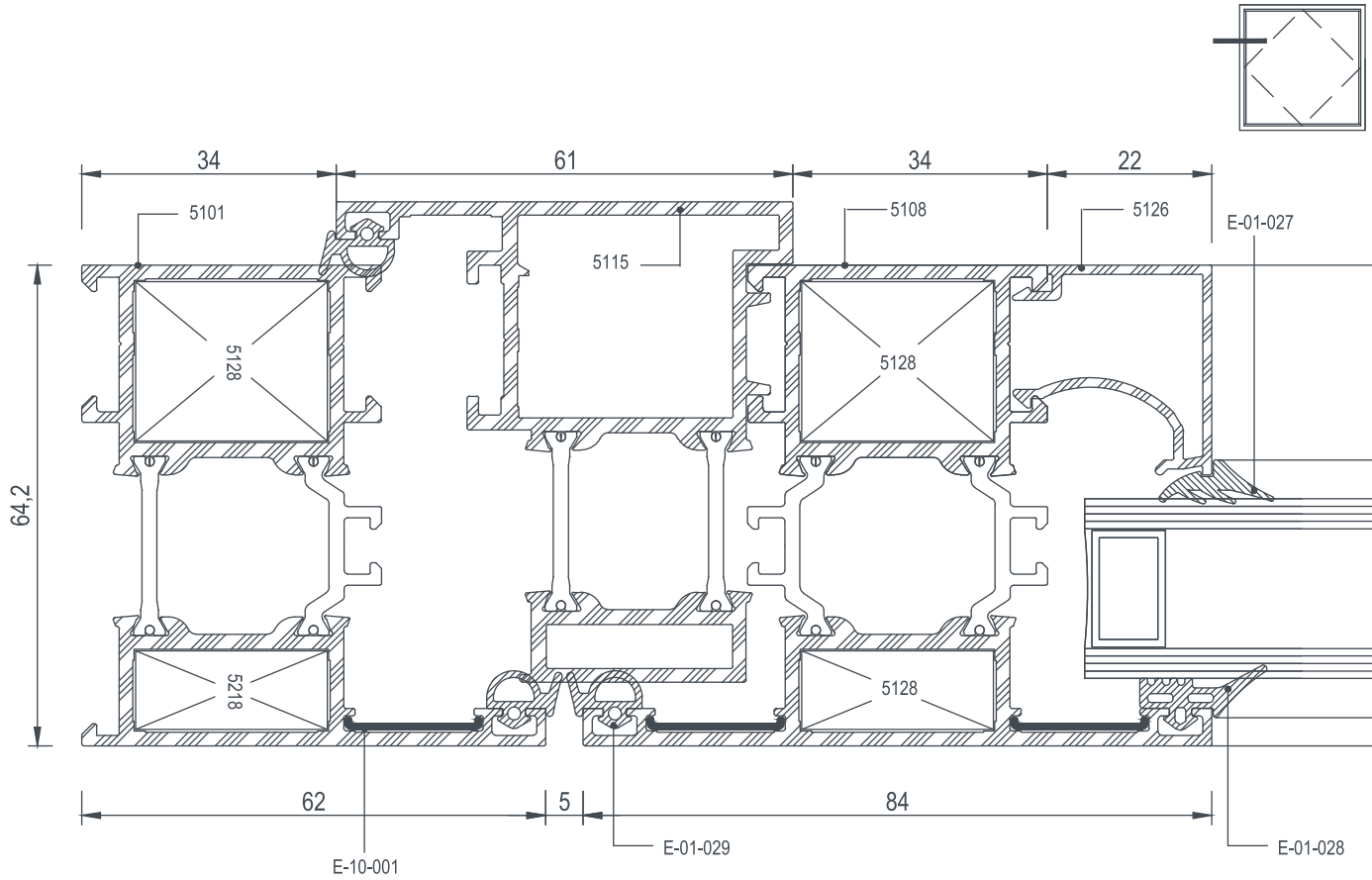



E 64

DETAYLAR / DETAILS

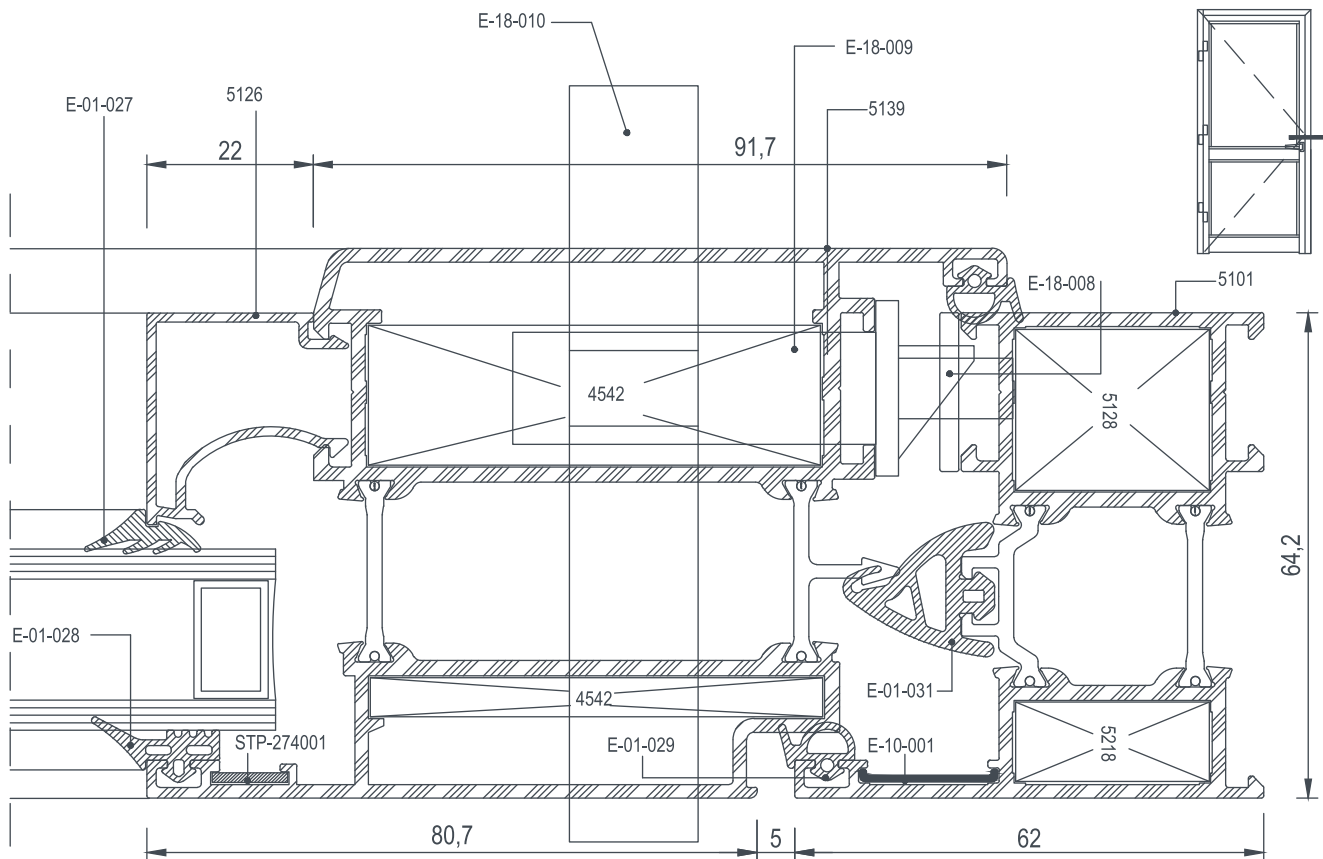
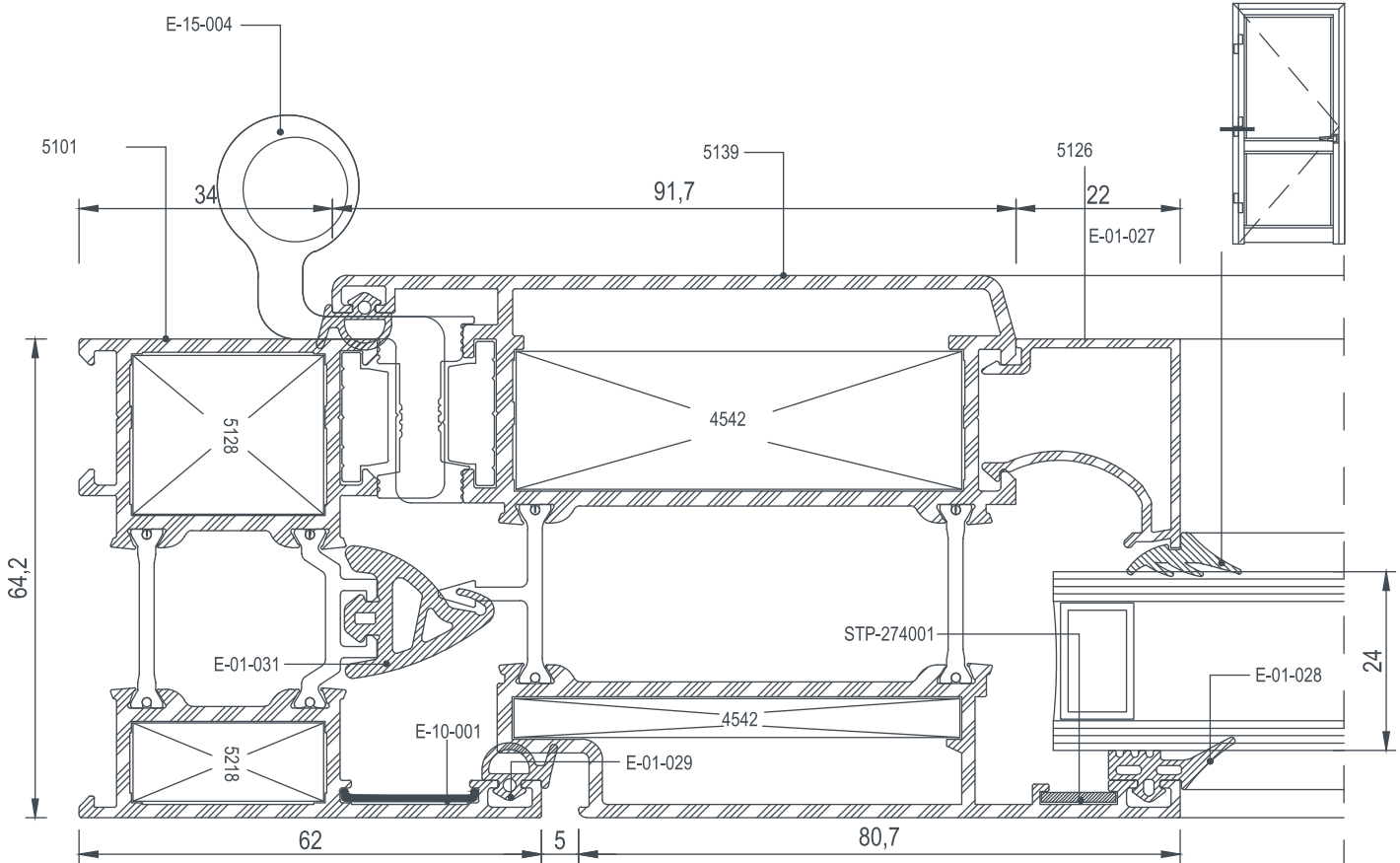



E 64

DETAYLAR / DETAILS

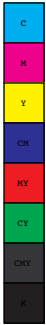
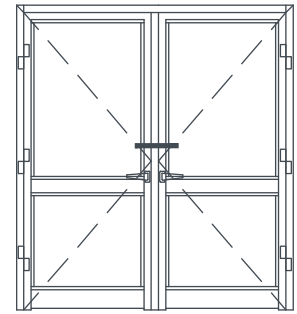
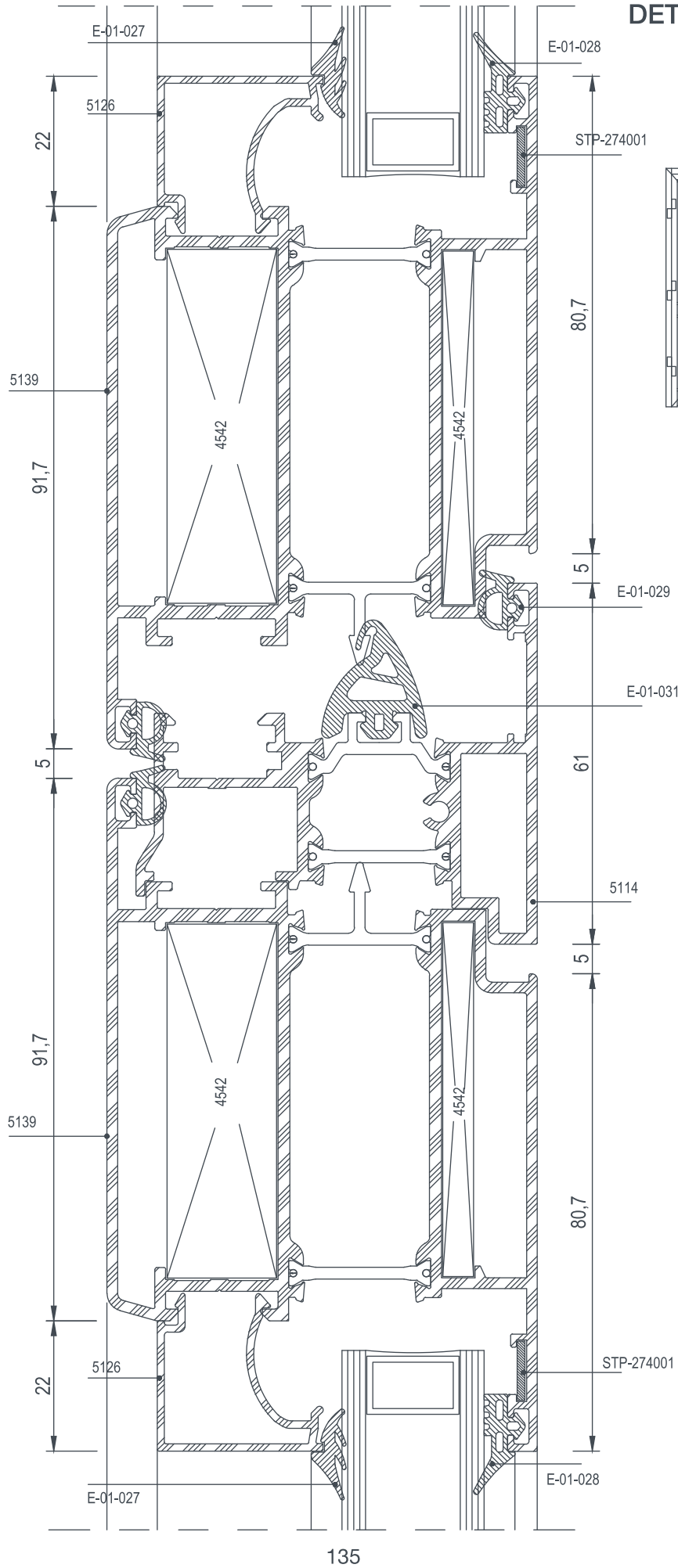



E 64

DEAYLAR / DETAILS

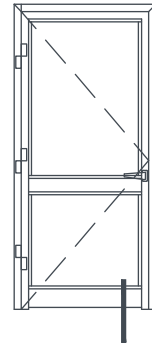
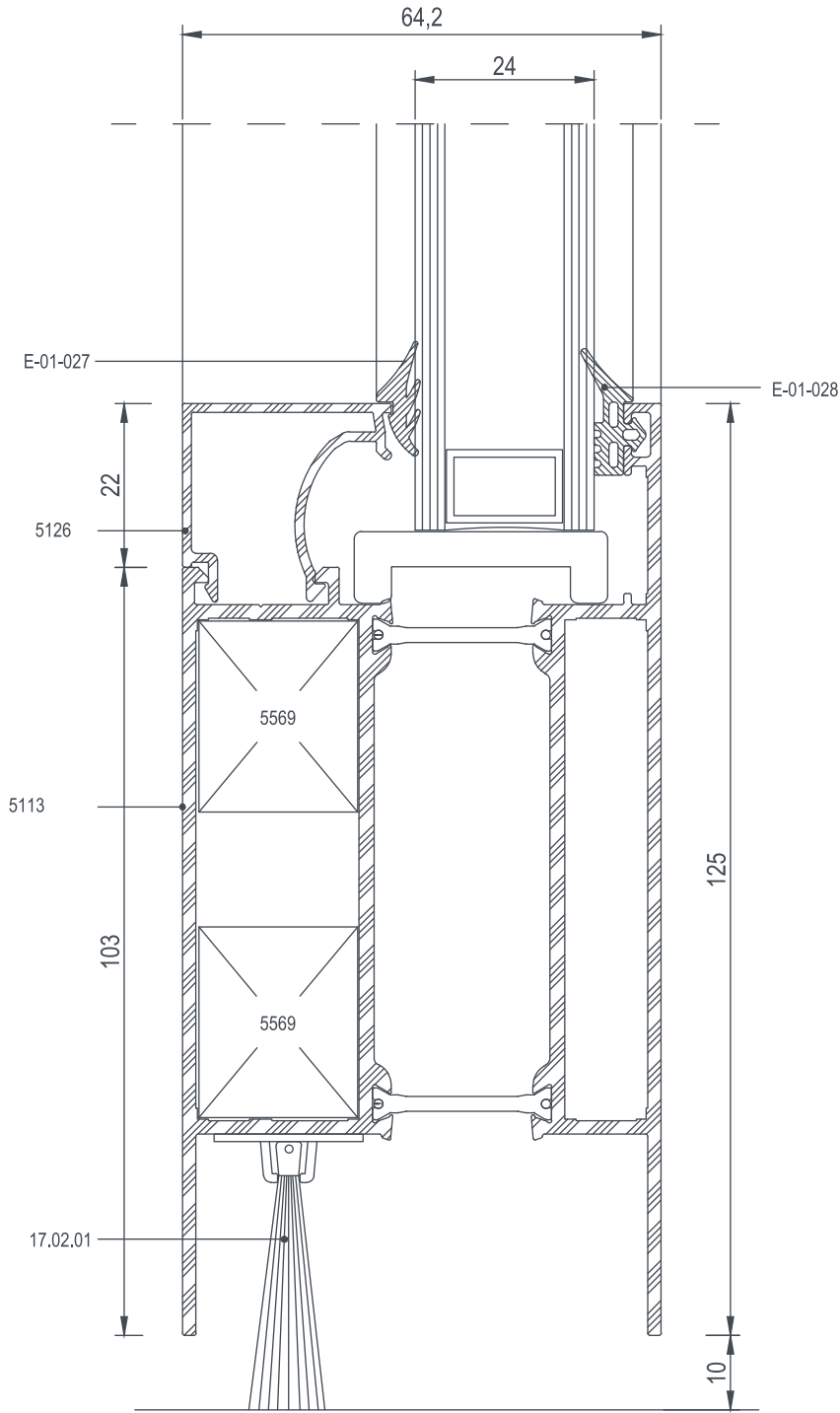



E 64

DEAYLAR / DETAILS

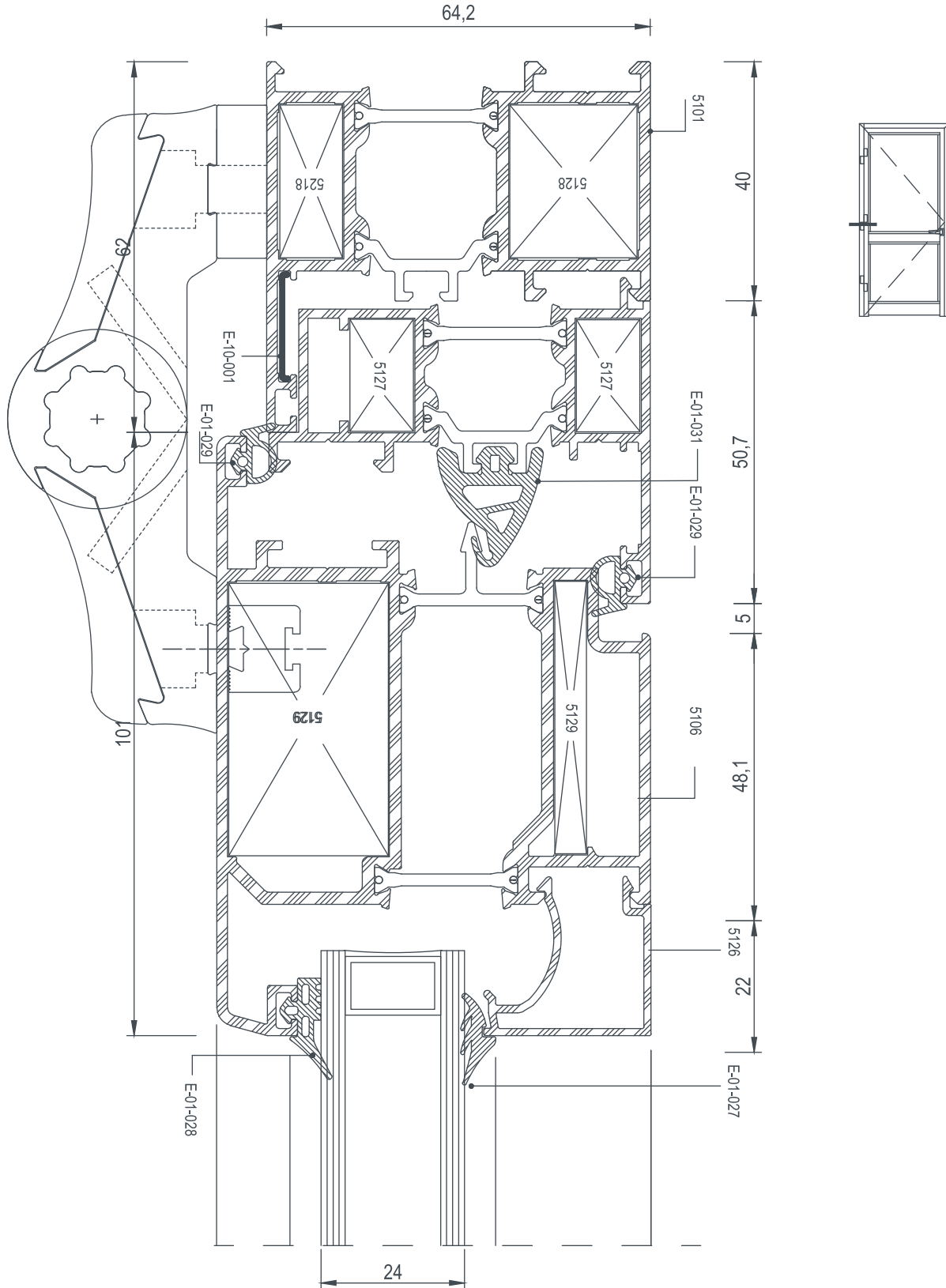



E 64

DEAYLAR / DETAILS

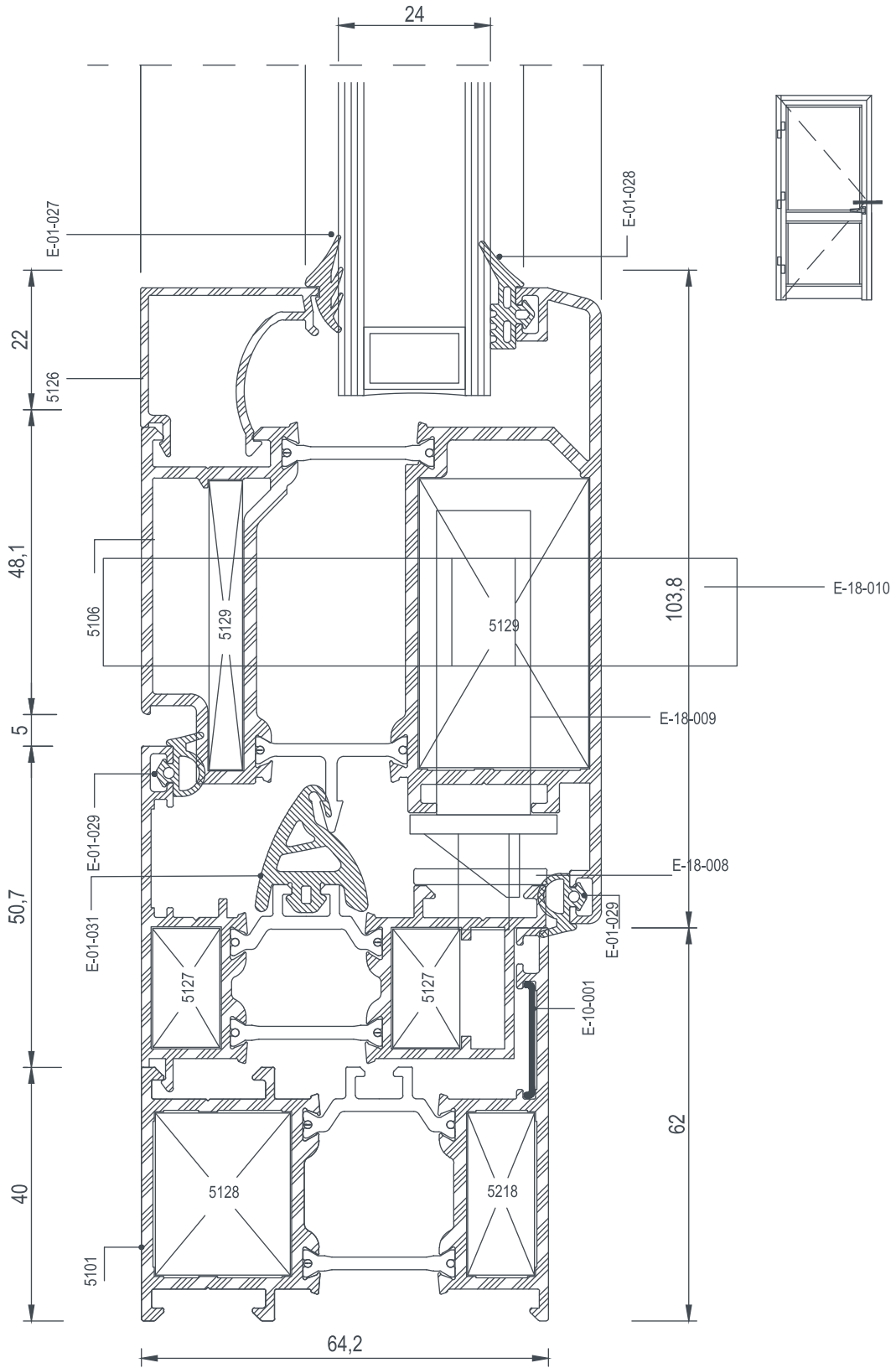



E 64

DEAYLAR / DETAILS

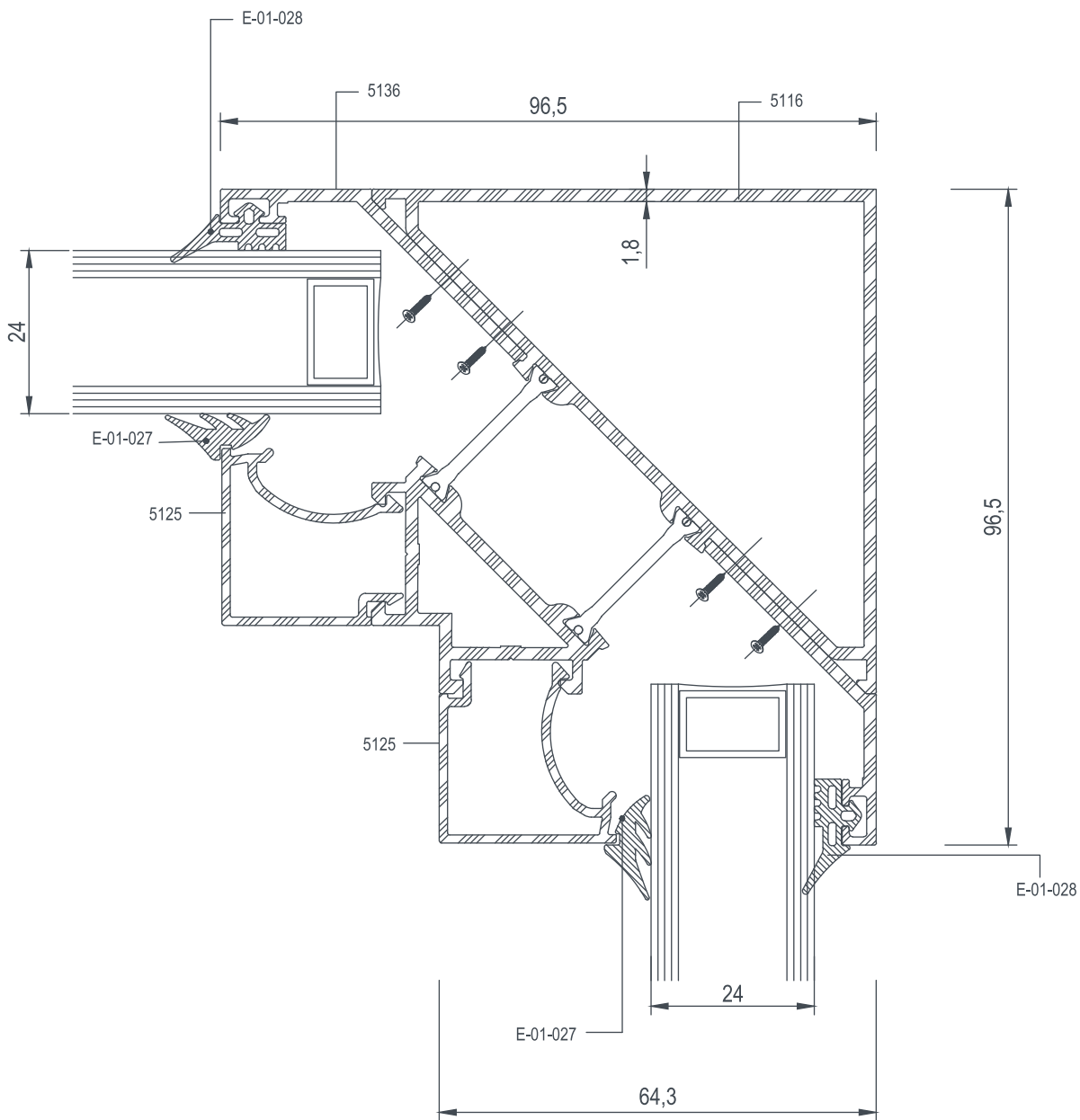
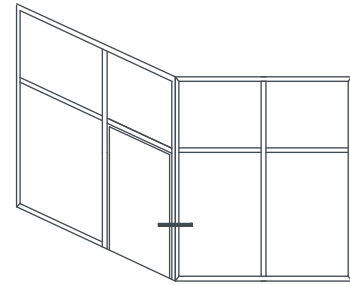



E 64

DEAYLAR / DETAILS

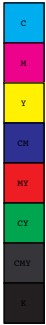
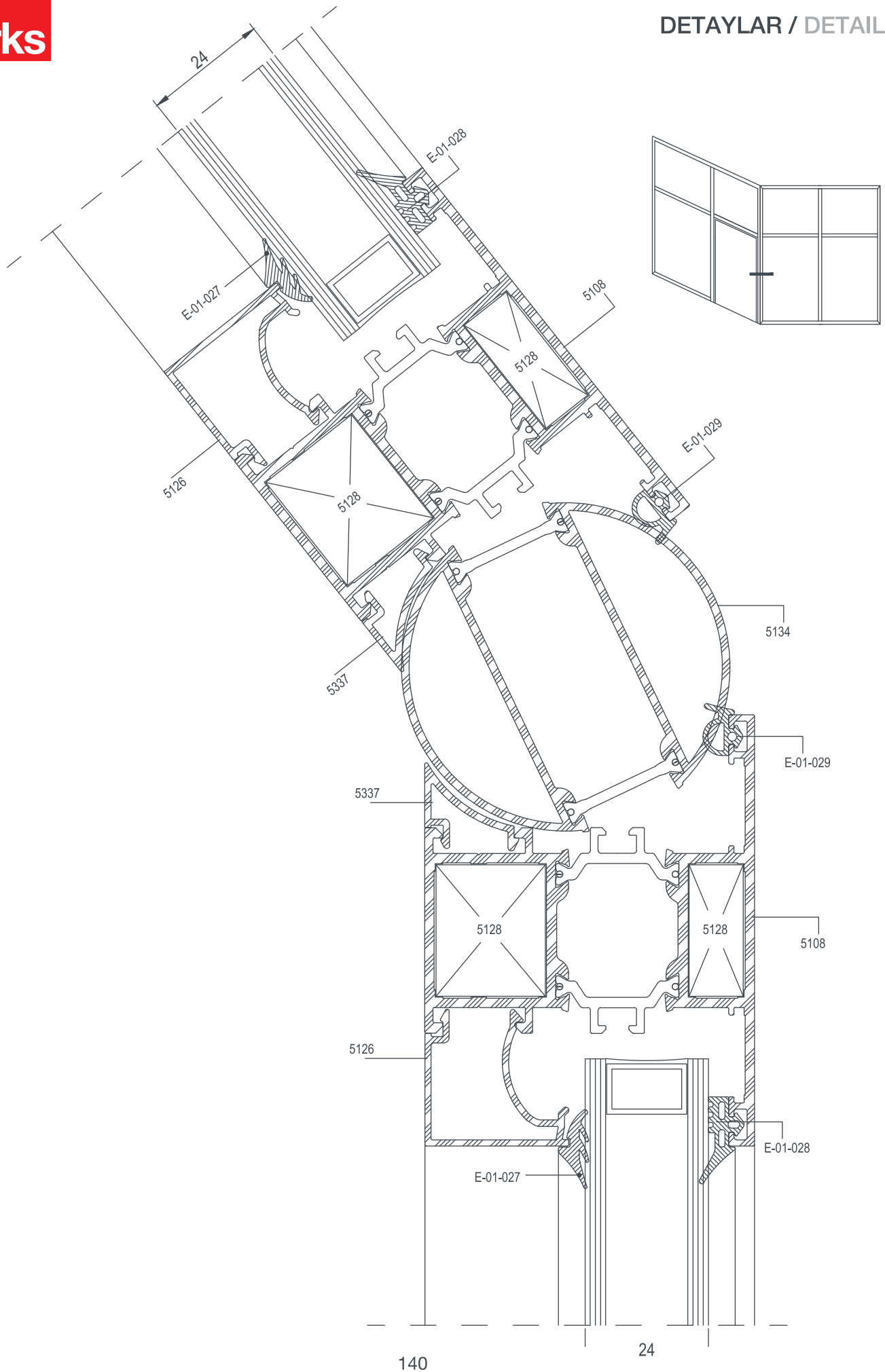



E 64

DEAYLAR / DETAILS

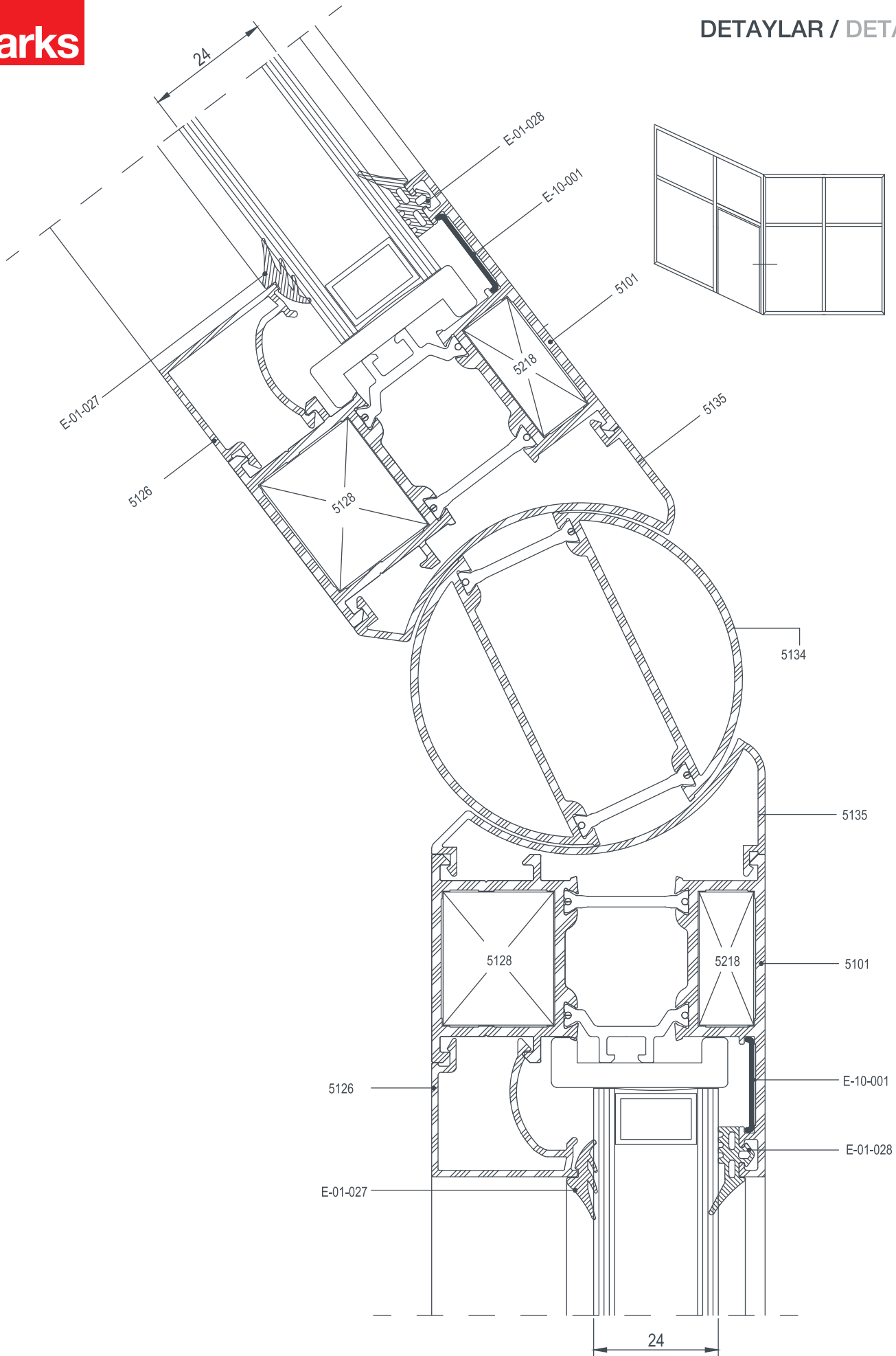



clarks

E 64

DETAYLAR

DETAILS

E 64 - 2.0T GİZLİ KANAT PROFİLİ DETAYLARI
E 64 - 2.0T SECRET SASH PROFILE DETAILS





E 64

DETAYLAR / DETAILS

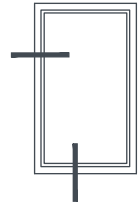
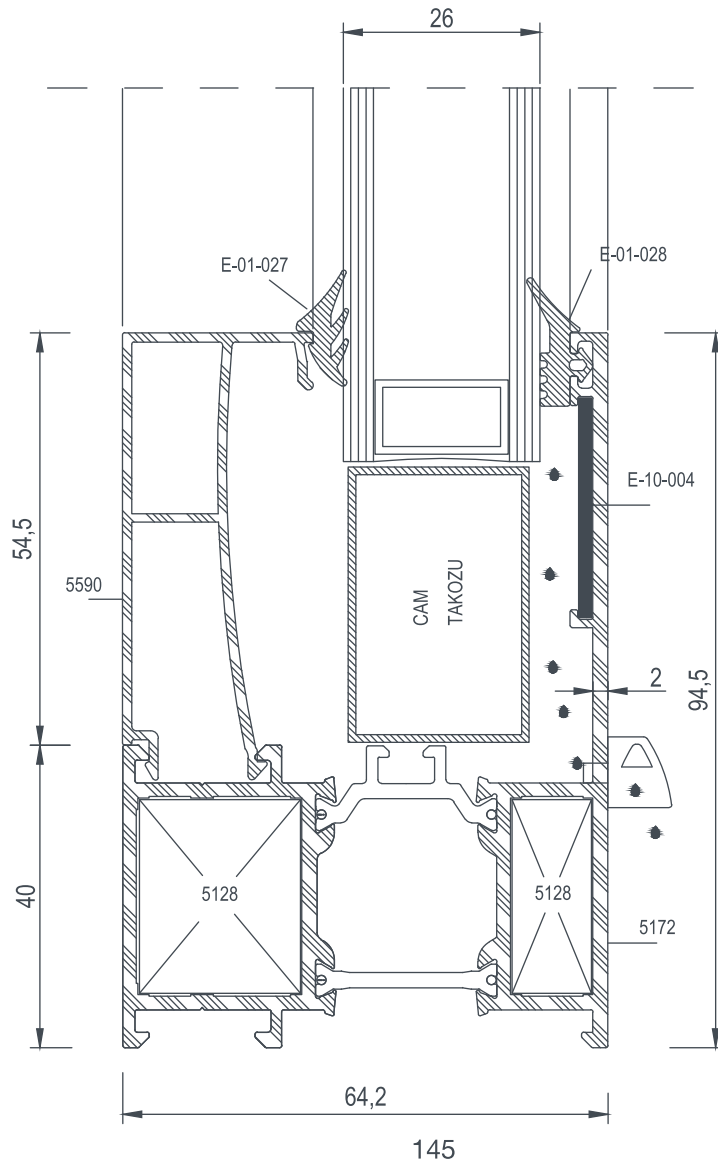
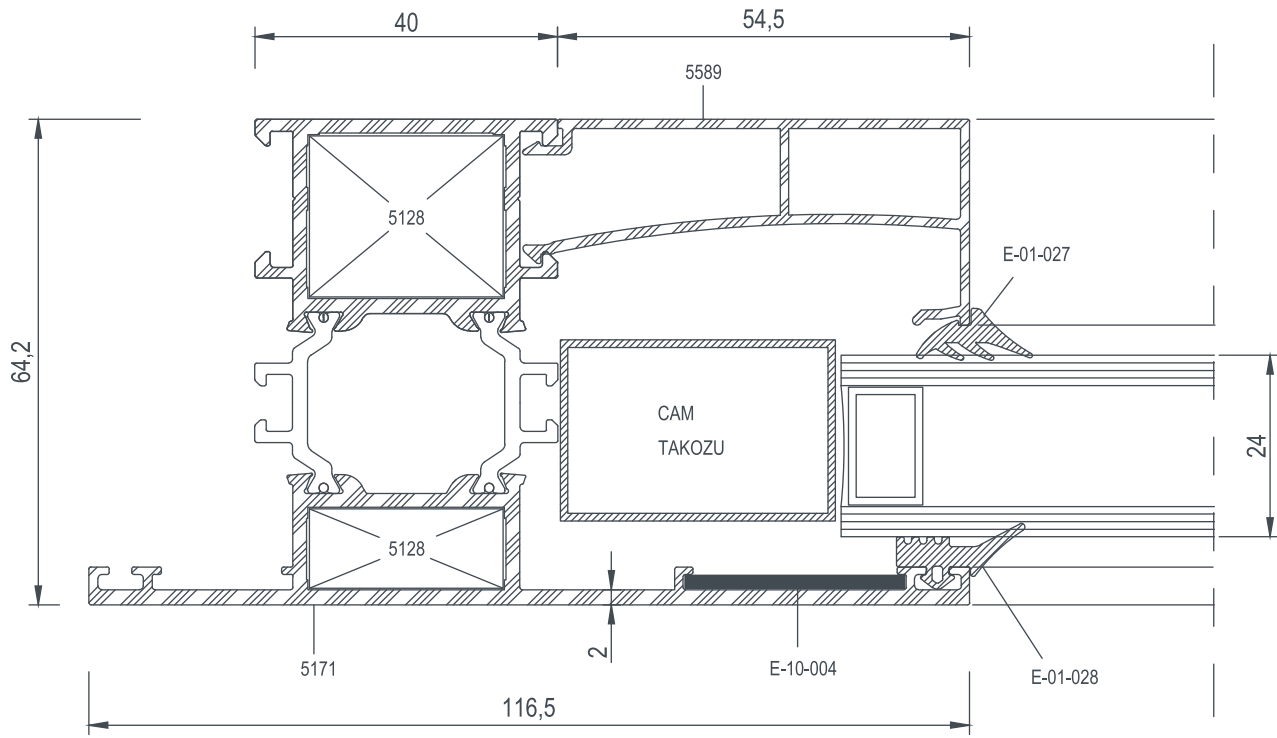



E 64

DEAYLAR / DETAILS

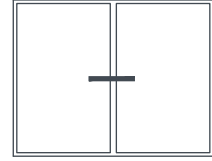
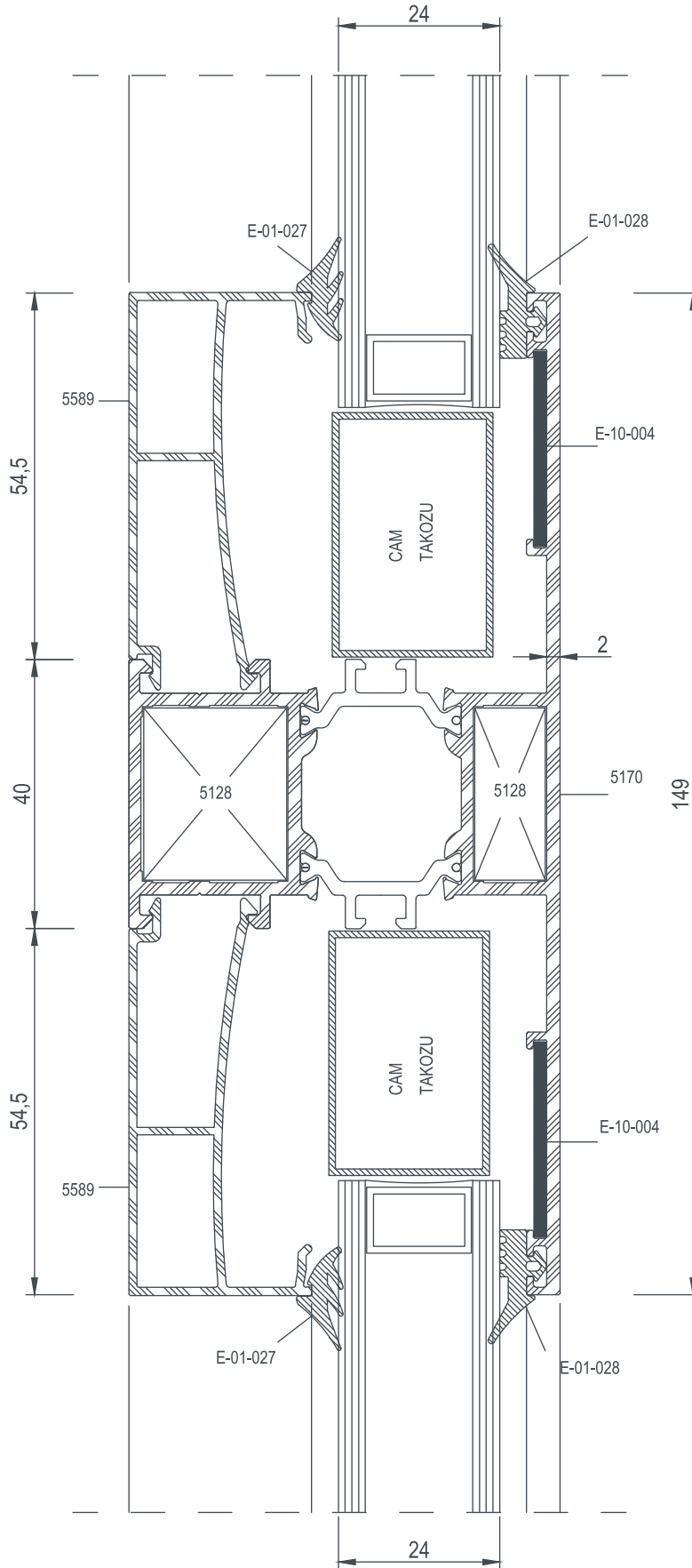



E 64

DEAYLAR / DETAILS

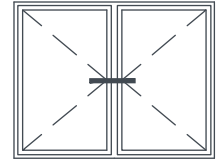
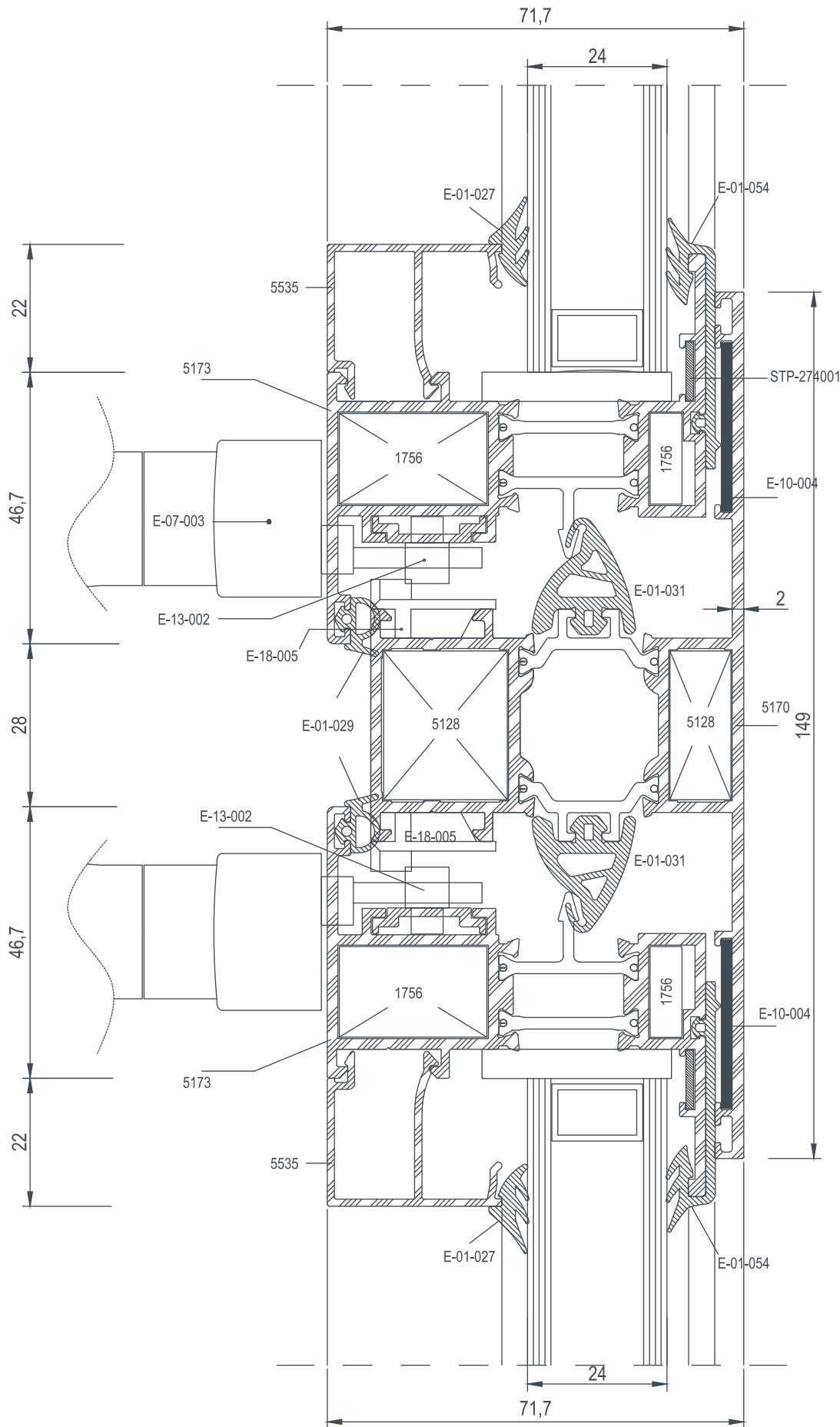



E 64

DEAYLAR / DETAILS

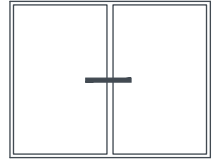
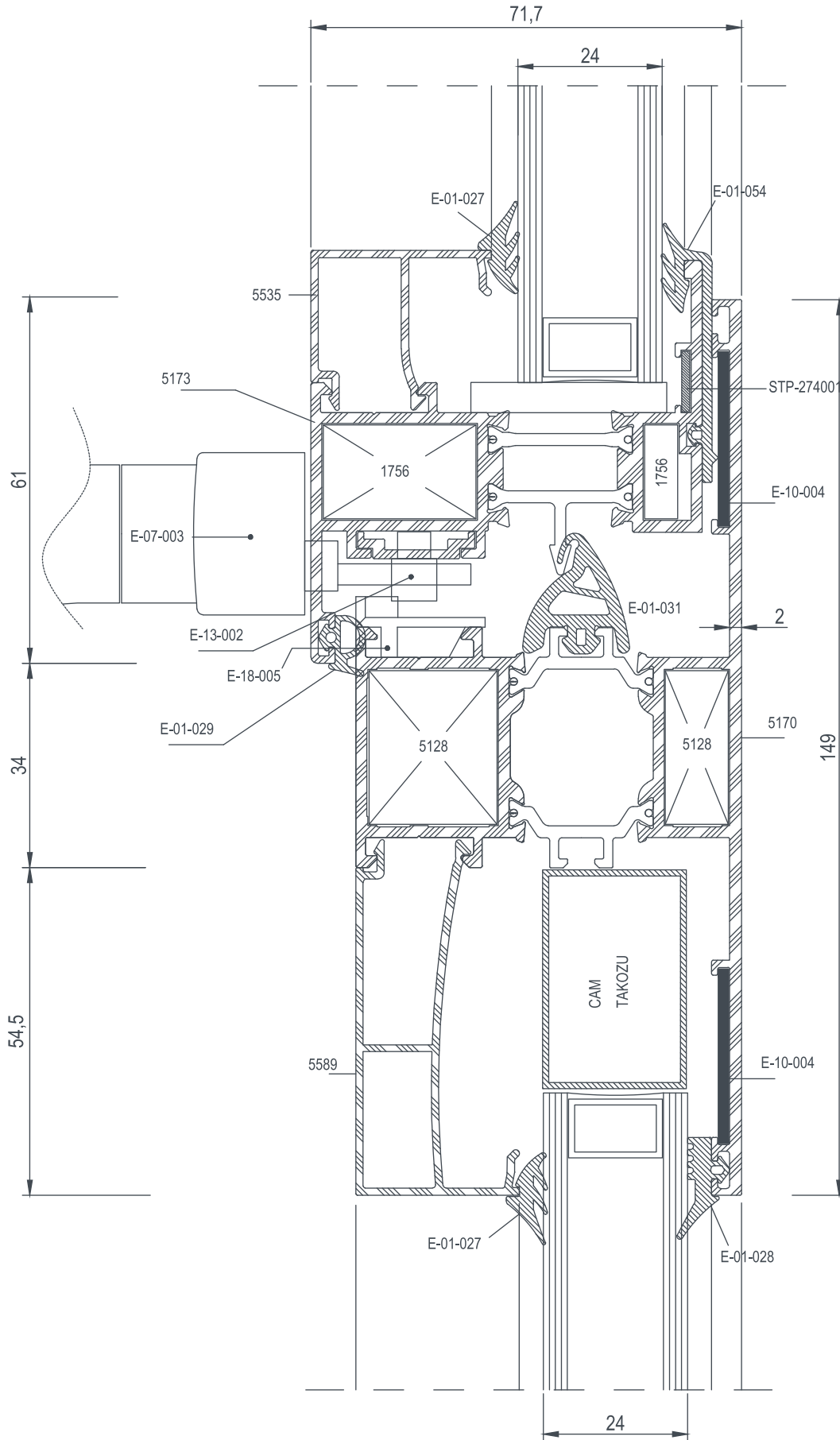



E 64

DETAYLAR / DETAILS

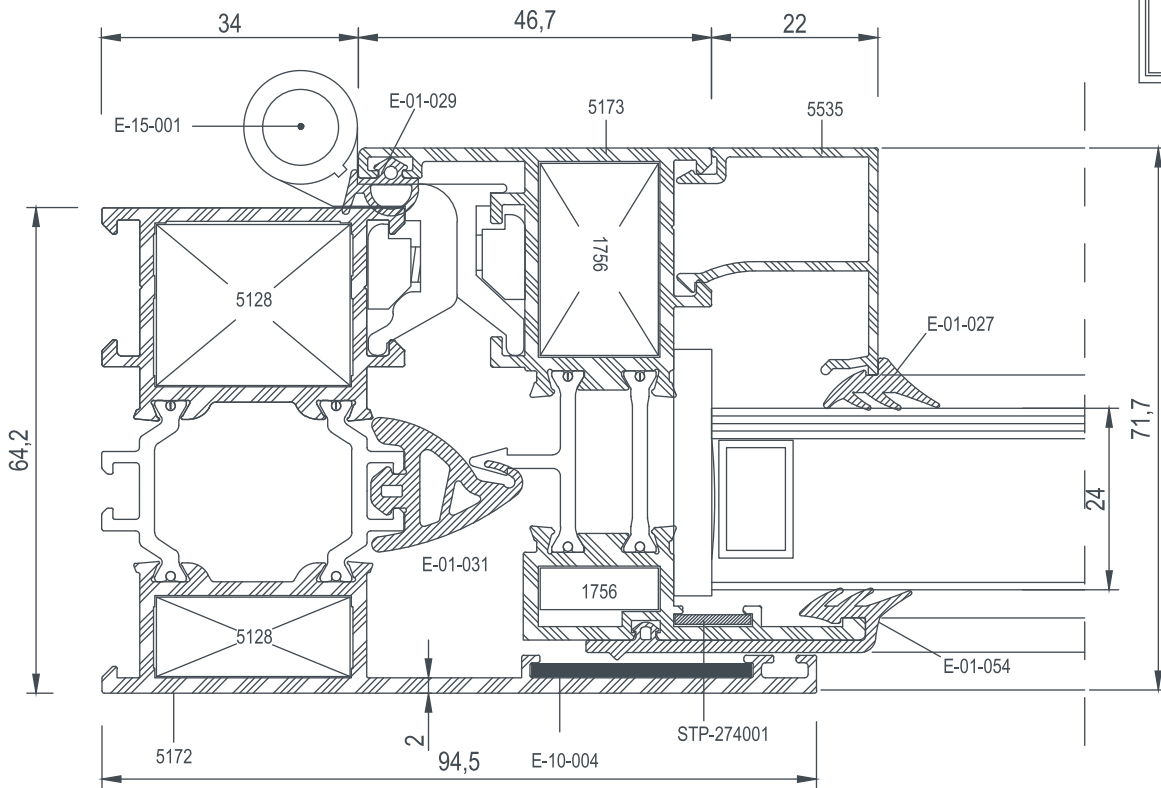
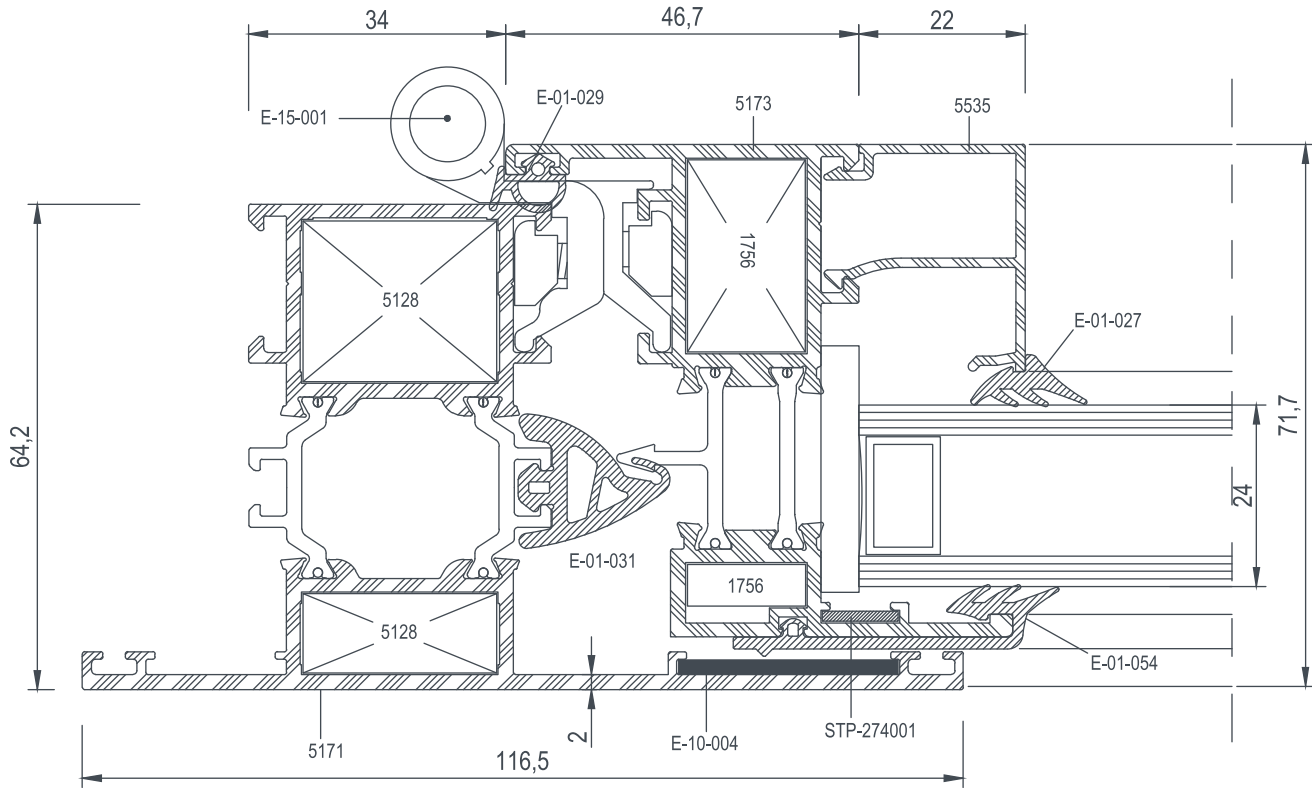



clarks

E 64











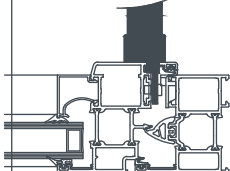

AKSESUARLAR
ACCESSORIES



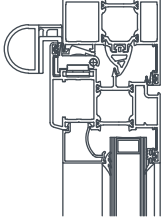

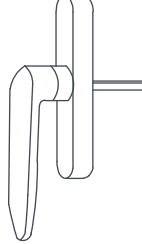
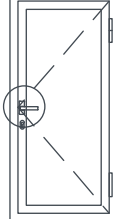
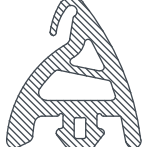
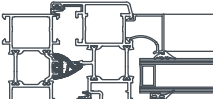
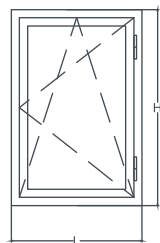
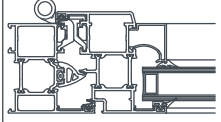
E 64

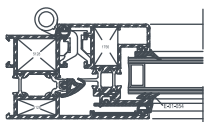

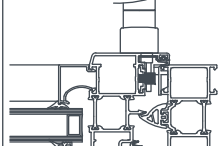

AKSESUARLAR / ACCESSORIES

	E-01-027 3mm iç cam fitili 3mm gasket 45 gr/mt			E-07-003 İspanyolet Kol Window handle	
	E-01-028 Dış cam fitili outside gasket 60 gr/mt			E-07-004 Vasistas Mandal Vasistas Spring	
	E-01-029 Dış Bini Fitili Acoustical Gasket 40 gr/mt			E-07-005 Kapı Kolu Door Handle	
	E-01-031 Tozluk Fitili Central gasket 183 gr/mt			E-07-006 Çift Açılım Mekanizması Tilt and Turn Mechanism L: 570~1000 mm H: 400~1200 mm	
	E-01-054 Gizli Kanat Fitili Secret Sash gasket 165 gr/mt			E-13-002 Tij Pimi Lock Pin	

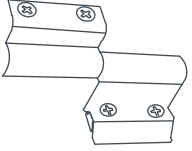
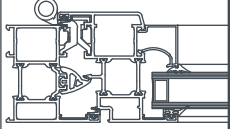

E 64

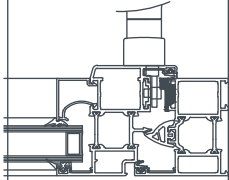
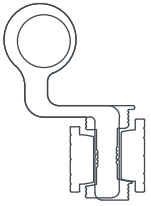
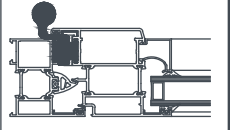
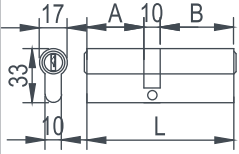
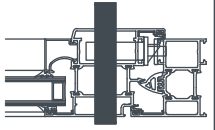
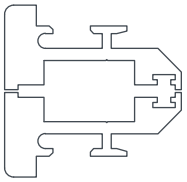
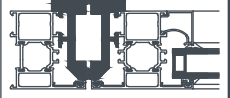
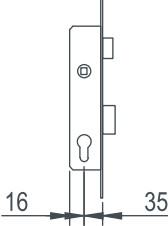
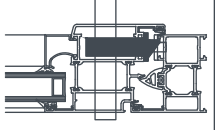
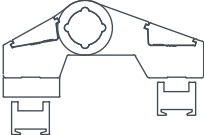
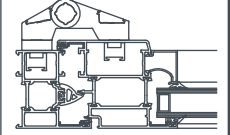

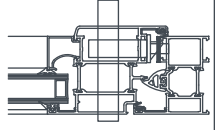
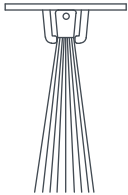
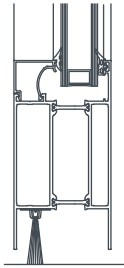
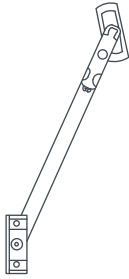
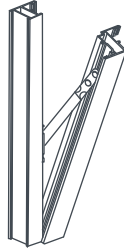

AKSESUARLAR / ACCESSORIES

	E-15-001 Pencere Menteşesi Window Hinge			E-18-005 Ayarlı Pim Karşılığı Lock Plate							
	E-15-004 Kapı Menteşesi Door Hinge		 <table border="1" data-bbox="936 1061 1077 1117"> <thead> <tr> <th>A</th> <th>B</th> <th>L</th> </tr> </thead> <tbody> <tr> <td>35</td> <td>55</td> <td>90</td> </tr> </tbody> </table>	A	B	L	35	55	90	E-18-010 Barel Cylinder	
A	B	L									
35	55	90									
	E-15-007 Pivot Menteşe Pivot Hinge			E-18-009 Dilli Kilit Mortise Lock							
	E-15-006 Kapı Menteşesi Door Hinge			E-18-008 Dilli Kilit Karşılığı Forend							
	E-17-003 Kapı Altı Fırçası Brush 1 Mt			E-23-002 Vasistas Makas Vasistas Accessory							

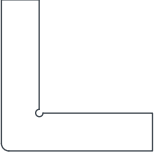

E 64

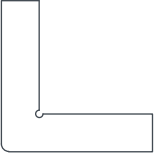
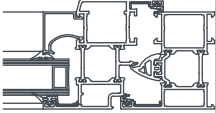
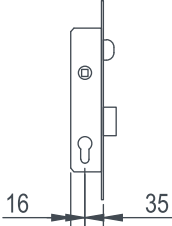
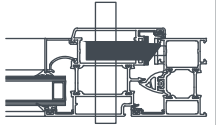
AKSESUARLAR / ACCESSORIES

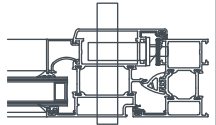
	<p>E-10-001 Köşe Çavuşu Corner joint</p>				
	<p>STP-274001 Köşe Çavuşu Corner joint</p>				
	<p>E-18-009-1 Makaralı Kilit Roller Lock</p>				
	<p>E-18-008-1 Makaralı Kilit Karşılığı Roller Lock Forend</p>				



clarks

E 74



E 74 - 1.5 - 1.8T - 2.0T
YALITIMLI PENCERE VE KAPI SİSTEMLERİ



E 74 - 1.5 - 1.8T - 2.0T
INSULATED WINDOWS & DOORS SYSTEMS



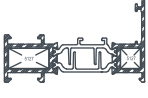
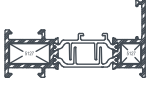
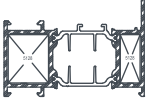
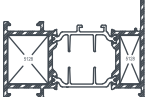
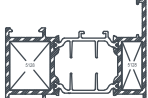
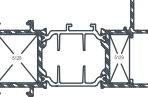
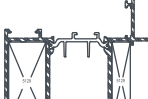
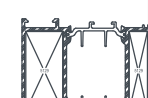

E 74

PROFİL İNDEKS / PROFILE INDEX

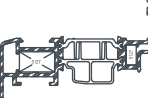
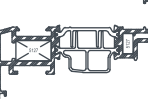
COD Code	PROFİL KESİTİ Profile View	PROFİL AÇIKLAMASI Profile Description	AGIRLIK (kg/m) Weight	Jxx cm ⁴	Jyy cm ⁴	Wxx cm ³	Wyy cm ³
5650		KASA PROFİLİ FRAME PROFILE	1,257	29,40	3,62	7,02	1,35
5500		KASA PROFİLİ FRAME PROFILE	1,318	31,60	3,73	7,55	1,40
5651		KASA PROFİLİ FRAME PROFILE	1,573	37,93	10,10	8,72	3,05
5501		KASA PROFİLİ FRAME PROFILE	1,658	41,20	10,55	9,50	3,20
5668		KASA PROFİLİ FRAME PROFILE	1,717	43,40	10,88	10,01	3,28
5669		KASA PROFİLİ FRAME PROFILE	1,846	59,45	14,16	11,22	4,30
5580		KASA PROFİLİ FRAME PROFILE	2,225	76,00	34,62	13,45	7,41
5652		KASA PROFİLİ FRAME PROFILE	1,953	49,52	26,62	10,34	6,42
5502		KASA PROFİLİ FRAME PROFILE	2,070	54,33	28,10	11,43	6,80
5653		KANAT PROFİLİ SASH PROFILE	1,534	44,41	4,04	8,68	1,83
5503		KANAT PROFİLİ SASH PROFILE	1,628	48,33	4,25	9,37	1,90

clarks

E 74

PROFİL İNDEKS / PROFILE INDEX

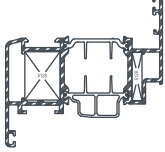
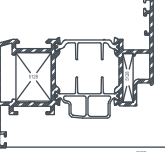
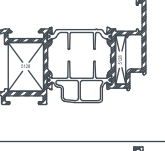
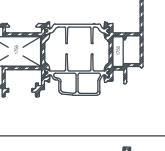
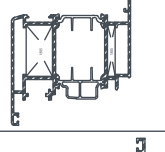
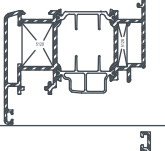
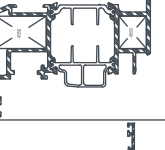
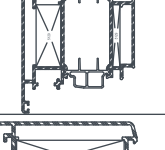
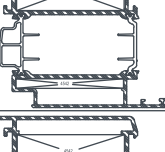
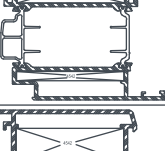
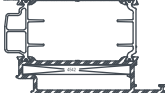
COD Code	PROFİL KESİTİ Profile View	PROFİL AÇIKLAMASI Profile Description	AGIRLIK (kg/m) Weight	Jxx cm4	Jyy cm4	Wxx cm3	Wyy cm3
5654		KANAT PROFİLİ SASH PROFILE	1,837	56,15	11,88	10,65	4,34
5504		KANAT PROFİLİ SASH PROFILE	1,966	61,76	12,93	11,77	4,73
5670		KANAT PROFİLİ SASH PROFILE	2,010	64,77	12,36	12,02	4,57
5655		PVC KANALLI PENCERE KANADI PVC CHANNEL SASH PROFILE	1,777	53,66	9,84	10,05	3,62
5656		PVC KANALLI PENCERE KANADI PVC CHANNEL SASH PROFILE	2,246	75,82	27,31	12,75	6,96
5556		PVC KANALLI PENCERE KANADI PVC CHANNEL SASH PROFILE	2,187	71,32	18,76	12,84	5,90
5671		PVC KANALLI PENCERE KANADI PVC CHANNEL SASH PROFILE	2,041	67,61	12,77	12,74	4,46
5557		PVC KANALLI PENCERE KANADI PVC CHANNEL SASH PROFILE	2,755	99,70	51,04	15,06	10,55
5657		İÇE AÇILIR KAPI KANAT PRF. INNER OPENING DOOR SASH PROFILE	2,515	90,08	48,00	13,32	9,36
5558		İÇE AÇILIR KAPI KANAT PRF. INNER OPENING DOOR SASH PROFILE	2,680	97,83	52,43	14,60	9,36
5672		İÇE AÇILIR KAPI KANAT PRF. INNER OPENING DOOR SASH PROFILE	2,759	104,17	52,28	15,60	10,60



E 74

PROFİL İNDEKS / PROFILE INDEX

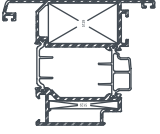
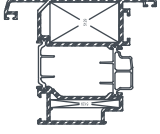
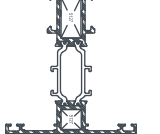
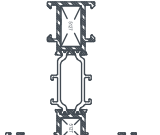
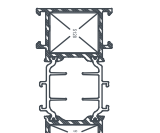
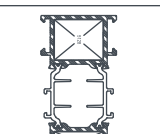
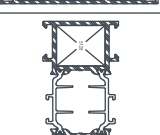
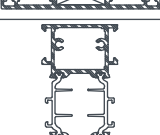
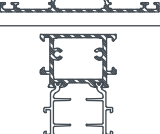
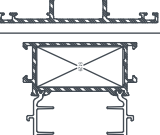
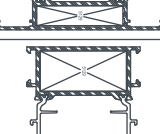
COD Code	PROFİL KESİTİ Profile View	PROFİL AÇIKLAMASI Profile Description	AGIRLIK (kg/m) Weight	Jxx cm ⁴	Jyy cm ⁴	Wxx cm ³	Wyy cm ³
5658		DIŞA AÇILIR KAPI KANAT PRF. OUTWARD OPENING DOOR SASH PROFILE	2,308	64,87	44,36	13,74	8,79
5506		DIŞA AÇILIR KAPI KANAT PRF. OUTWARD OPENING DOOR SASH PROFILE	2,490	72,70	48,31	15,42	9,51
5659		ORTA KAYIT PROFİLİ MULLION PROFILE	1,403	33,31	7,63	7,60	2,21
5507		ORTA KAYIT PROFİLİ MULLION PROFILE	1,472	35,71	7,96	8,15	2,30
5660		ORTA KAYIT PROFİLİ MULLION PROFILE	1,716	41,62	16,53	9,67	3,93
5508		ORTA KAYIT PROFİLİ MULLION PROFILE	1,812	45,21	17,37	10,51	4,13
5673		ORTA KAYIT PROFİLİ MULLION PROFILE	1,881	66,56	22,18	16,43	5,28
5662		VİDALI ORTA KAYIT PROFİLİ SCREW MULLION PROFILE	1,795	44,48	16,90	10,74	4,02
5510		VİDALI ORTA KAYIT PROFİLİ SCREW MULLION PROFILE	1,885	52,30	37,77	12,31	7,26
5661		ORTA KAYIT PROFİLİ MULLION PROFILE	2,098	52,30	37,77	12,31	7,26
5509		ORTA KAYIT PROFİLİ MULLION PROFILE	2,224	57,40	39,90	13,56	7,67

clarks

E 74







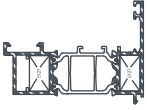

PROFİL İNDEKS / PROFILE INDEX

COD Code	PROFİL KESİTİ Profile View	PROFİL AÇIKLAMASI Profile Description	AGIRLIK (kg/m) Weight	Jxx cm4	Jyy cm4	Wxx cm3	Wyy cm3
5663		TAKV.ORTA KAYIT PROFİLİ SUPPORTED MULLION PROFILE	2,316	110,91	26,66	17,83	6,34
5511		TAKV.ORTA KAYIT PROFİLİ SUPPORTED MULLION PROFILE	2,526	125,24	29,33	19,73	6,98
5664		TAKV.ORTA KAYIT PROFİLİ SUPPORTED MULLION PROFILE	2,509	160,67	24,50	7,60	2,21
5512		TAKV.ORTA KAYIT PROFİLİ SUPPORTED MULLION PROFILE	2.728	177,13	26,77	21,14	6,37
5665		ETEK PROFİLİ KICK PROFILE	2,478	81,00	62,22	11,00	10,46
5513		ETEK PROFİLİ KICK PROFILE	2,669	89,43	69,49	12,22	11,41
5673		ETEK PROFİLİ KICK PROFILE	2,834	95,24	74,43	13,07	12,10
5666		ÇİFT KANAT ADAPTÖR PROF. DOUBLE SASH ADAPTER PROFILE	1,472	33,31	7,63	7,11	2,22
5514		ÇİFT KANAT ADAPTÖR PROF. DOUBLE SASH ADAPTER PROFILE	1,549	35,02	8,18	7,30	2,34
5667		PİVOT ADAPTÖR PROFİLİ PIVOTING ADAPTER PROFILE	1,516	34,33	9,42	7,50	3,08
5515		PİVOT ADAPTÖR PROFİLİ PIVOTING ADAPTER PROFILE	1,625	37,84	10,37	8,28	3,31

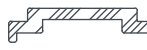
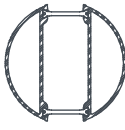
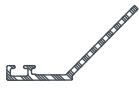

E 74











PROFİL İNDEKS / PROFILE INDEX

COD Code	PROFİL KESİTİ Profile View	PROFİL AÇIKLAMASI Profile Description	AGIRLIK (kg/m) Weight	Jxx cm4	Jyy cm4	Wxx cm3	Wyy cm3
5558		DIŞA AÇILIR KAPI ADAPTÖRÜ OUTWARD OPENING DOOR ADAPTER	1,288	27,10	5,46	6,53	1,84
5516		KÖŞE DÖNÜŞ PROFİLİ CORNER PROFILE	2,151	61,14	40,77	10,82	7,78
5117		TİJ PROFİLİ SASH PROFILE	0,105	----	----	----	----
5560		KÖŞE DÖNÜŞ PROFİLİ CORNER PROFILE	1,674	25,92	25,21	7,00	7,10
5337		ADAPTÖR PROFİLİ ADAPTER PROFILE	0,151	----	----	----	----
5559		ADAPTÖR PROFİLİ ADAPTER PROFILE	0,324	3,28	0,16	1,07	0,20
5561		ADAPTÖR PROFİLİ ADAPTER PROFILE	0,471	11,47	0,56	2,67	0,37
5572		TİJ PROFİLİ SASH PROFILE	0,100	----	----	----	----
5118		CAM ÇİTASI PROFİLİ GLAZING BEAD	0,249	----	----	----	----
5119		CAM ÇİTASI PROFİLİ GLAZING BEAD	0,251	----	----	----	----
5120		CAM ÇİTASI PROFİLİ GLAZING BEAD	0,255	----	----	----	----



E 74







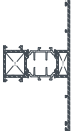
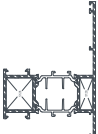
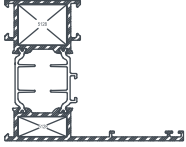
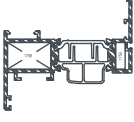

PROFİL İNDEKS / PROFILE INDEX

COD Code	PROFİL KESİTİ Profile View	PROFİL AÇIKLAMASI Profile Description	AGIRLIK (kg/m) Weight	Jxx cm4	Jyy cm4	Wxx cm3	Wyy cm3
5121		CAM ÇİTASI PROFİLİ GLAZING BEAD	0,260	----	----	----	----
5122		CAM ÇİTASI PROFİLİ GLAZING BEAD	0,267	----	----	----	----
5123		CAM ÇİTASI PROFİLİ GLAZING BEAD	0,274	----	----	----	----
5124		CAM ÇİTASI PROFİLİ GLAZING BEAD	0,281	----	----	----	----
5125		CAM ÇİTASI PROFİLİ GLAZING BEAD	0,292	----	----	----	----
5526		CAM ÇİTASI PROFİLİ GLAZING BEAD	0,308	----	----	----	----
5535		CAM ÇİTASI PROFİLİ GLAZING BEAD	0,305	----	----	----	----
5536		CAM ÇİTASI PROFİLİ GLAZING BEAD	0,312	----	----	----	----
5537		CAM ÇİTASI PROFİLİ GLAZING BEAD	0,318	----	----	----	----
5538		CAM ÇİTASI PROFİLİ GLAZING BEAD	0,325	----	----	----	----
5539		CAM ÇİTASI PROFİLİ GLAZING BEAD	0,331	----	----	----	----



E 74











PROFİL İNDEKS / PROFILE INDEX

COD Code	PROFİL KESİTİ Profile View	PROFİL AÇIKLAMASI Profile Description	AGIRLIK (kg/m) Weight	Jxx cm4	Jyy cm4	Wxx cm3	Wyy cm3
5674		ORTA KAYIT PROFİLİ MULLION PROFILE	2,223	72,89	56,06	9,78	11,33
5675		ORTA KAYIT PROFİLİ MULLION PROFILE	2,038	59,36	35,46	9,81	6,39
5676		KASA PROFİLİ FRAME PROFILE	1,873	59,27	22,18	9,84	5,33
5677		KANAT PROFİLİ SASH PROFILE	1,570	40,24	5,84	8,83	2,31
5587		CAM ÇITASI PROFİLİ GLAZING BEAD	0,510	6,36	0,82	1,97	0,75
5588		CAM ÇITASI PROFİLİ GLAZING BEAD	0,521	6,63	1,05	2,00	0,90
5589		CAM ÇITASI PROFİLİ GLAZING BEAD	0,548	7,30	1,18	2,11	0,73
5590		CAM ÇITASI PROFİLİ GLAZING BEAD	0,542	7,13	1,08	2,08	0,73
5591		CAM ÇITASI PROFİLİ GLAZING BEAD	0,534	6,97	1,00	2,06	0,74
5592		CAM ÇITASI PROFİLİ GLAZING BEAD	0,554	7,47	1,30	2,14	0,74
5593		CAM ÇITASI PROFİLİ GLAZING BEAD	0,560	7,65	1,41	2,17	0,76

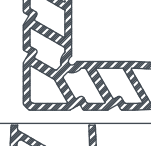

E 74

PROFİL İNDEKS / PROFILE INDEX

COD Code	PROFİL KESİTİ Profile View	PROFİL AÇIKLAMASI Profile Description	AGIRLIK (kg/m) Weight	Jxx cm4	Jyy cm4	Wxx cm3	Wyy cm3
5594		CAM ÇITASI PROFİLİ GLAZING BEAD	0,567	7,83	1,55	2,20	0,78
5595		CAM ÇITASI PROFİLİ GLAZING BEAD	0,573	8,02	1,70	2,23	0,81
1756		KÖŞE TAKOZ PROFİLİ CORNER JOINT	2,474	----	----	----	----
1885		KÖŞE TAKOZ PROFİLİ CORNER JOINT	4,471	----	----	----	----
4550		KÖŞE TAKOZ PROFİLİ CORNER JOINT	3,581	----	----	----	----
5127		KÖŞE TAKOZ PROFİLİ CORNER JOINT	3,484	----	----	----	----
5128		KÖŞE TAKOZ PROFİLİ CORNER JOINT	3,652	----	----	----	----
5129		KÖŞE TAKOZ PROFİLİ CORNER JOINT	4,618	----	----	----	----
4542		KÖŞE TAKOZ PROFİLİ CORNER JOINT	5,381	----	----	----	----
5570		" U " BAĞ. PROFİLİ " U " LINKING PROFILE	0,393	----	----	----	----
5569		" U " BAĞ. PROFİLİ " U " LINKING PROFILE	0,555	----	----	----	----



E 74

PROFİL İNDEKS / PROFILE INDEX

COD Code	PROFİL KESİTİ Profile View	PROFİL AÇIKLAMASI Profile Description	AGIRLIK (kg/m) Weight	Jxx cm4	Jyy cm4	Wxx cm3	Wyy cm3
5571		" U " BAĞ. PROFİLİ " U " LINKING PROFILE	0,772	----	----	----	----



clarks

E 74

PROFİLLER

PROFILES

E 74 - 1.5 - 1.8 - 2.0 T YALITIMLI SERİ
E 74 - 1.5 - 1.8 - 2.0 T INSULATION SERIES

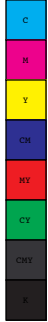

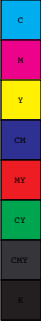



E 74

PROFİLLER / PROFILES

COD Code	AGIRLIK (kg/m) Weight	Jxx cm4	Jyy cm4	Wxx cm3	Wyy cm3	L m
5650	1,257	29,40	3,62	7,02	1,35	6
5500	1,318	31,60	3,73	7,55	1,40	6
5651	1,573	37,93	10,10	8,72	3,05	6
5501	1,658	41,20	10,55	9,50	3,20	6
5668	1,717	43,40	10,88	10,01	3,28	6

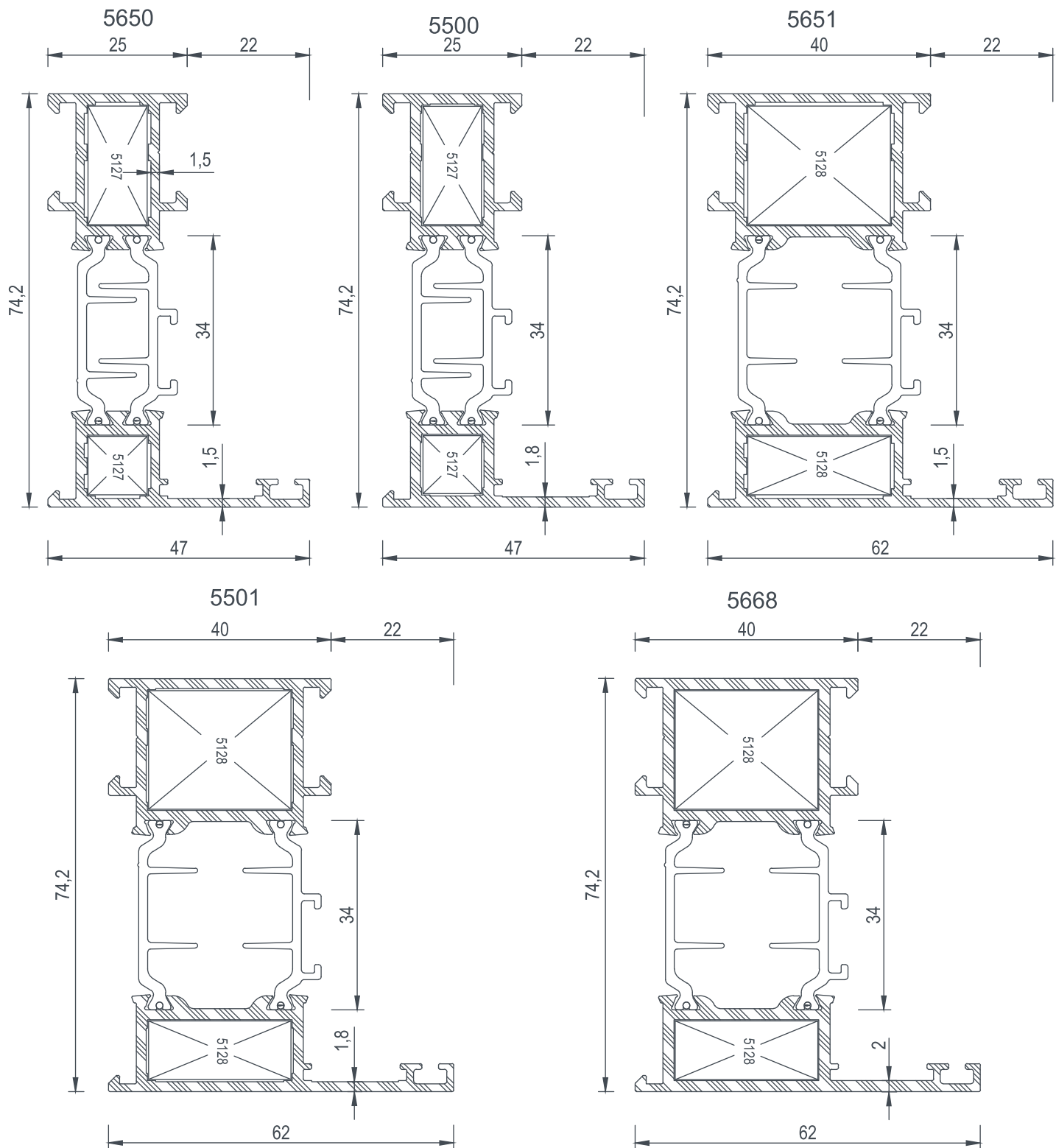



E 74

PROFİLLER / PROFILES

COD Code	AGIRLIK (kg/m) Weight	Jxx cm4	Jyy cm4	Wxx cm3	Wyy cm3	L m
5669	1,846	59,45	14,16	11,22	4,30	6
5580	2,225	76,00	34,62	13,45	7,41	6
5652	1,953	49,52	26,62	10,34	6,42	6
5502	2,070	54,33	28,10	11,43	6,80	6

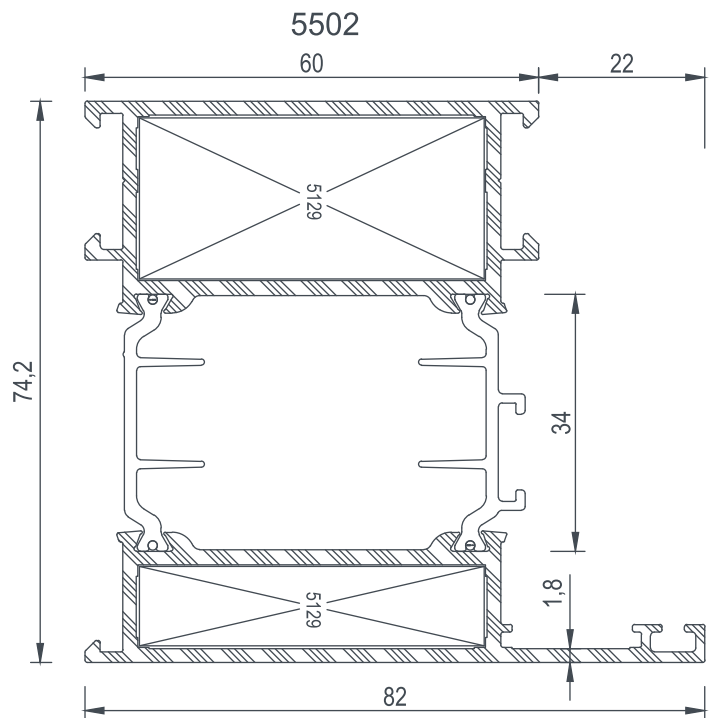
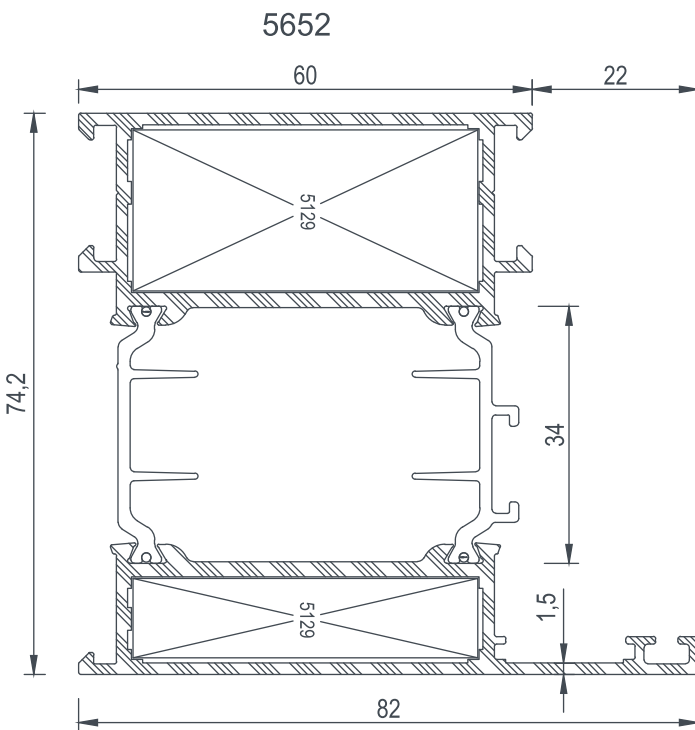
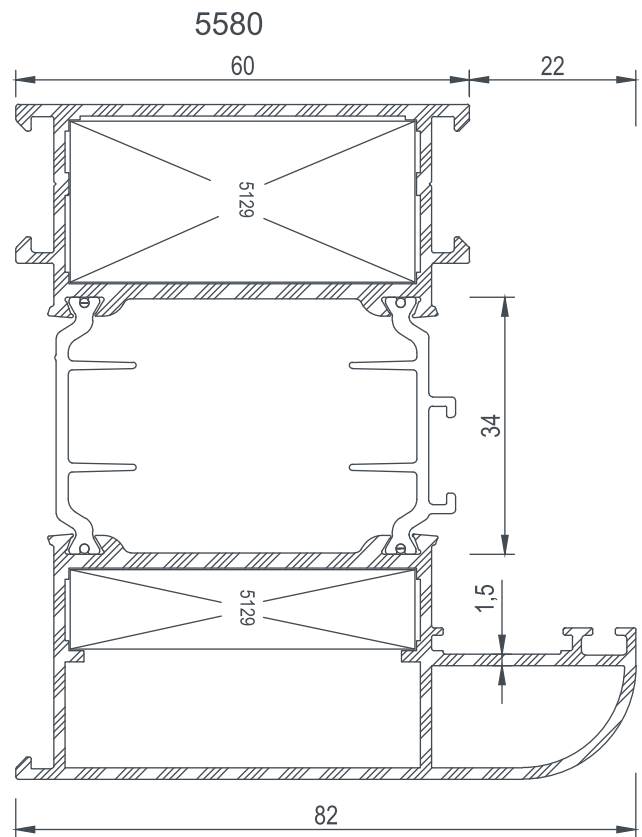
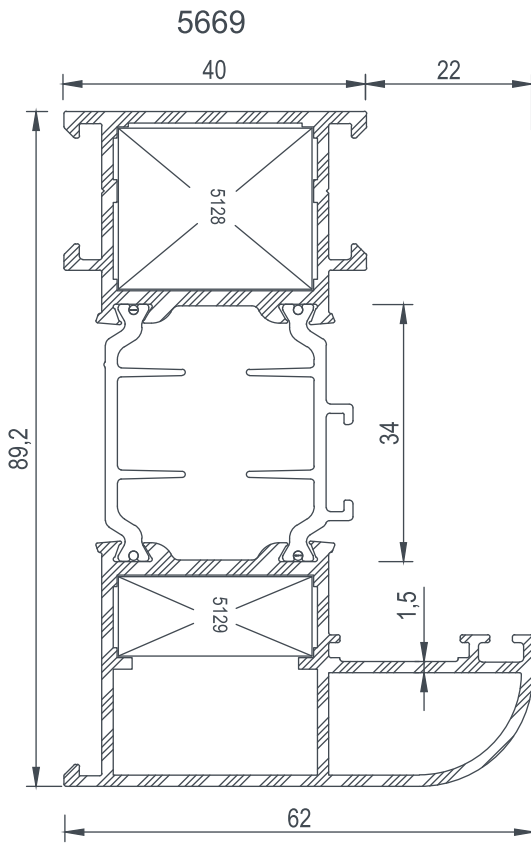

172





E 74

PROFİLLER / PROFILES

COD Code	AGIRLIK (kg/m) Weight	Jxx cm4	Jyy cm4	Wxx cm3	Wyy cm3	L m
5689	1,457	7,32	48,44	7,50	2,15	6
5690	1,850	19,07	60,49	7,23	2,32	6

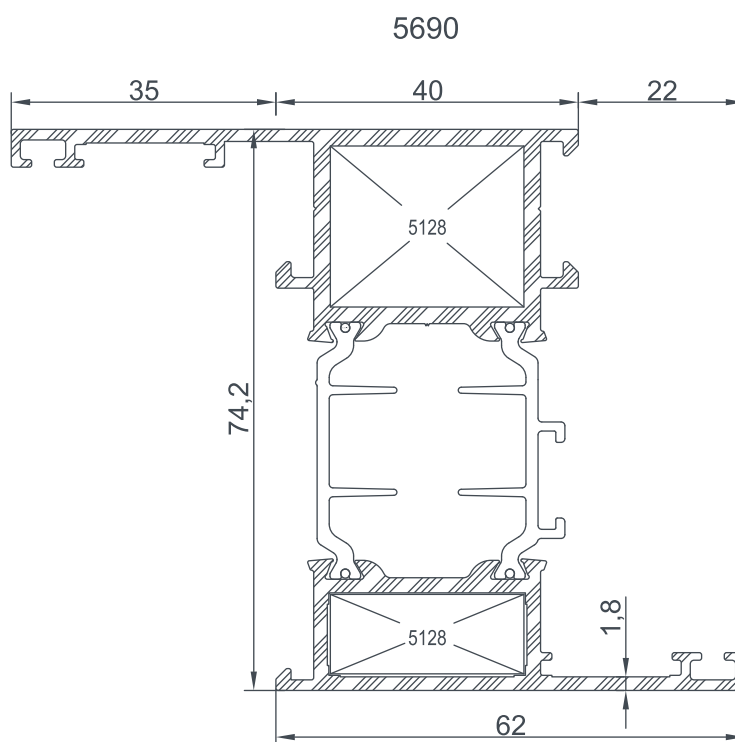
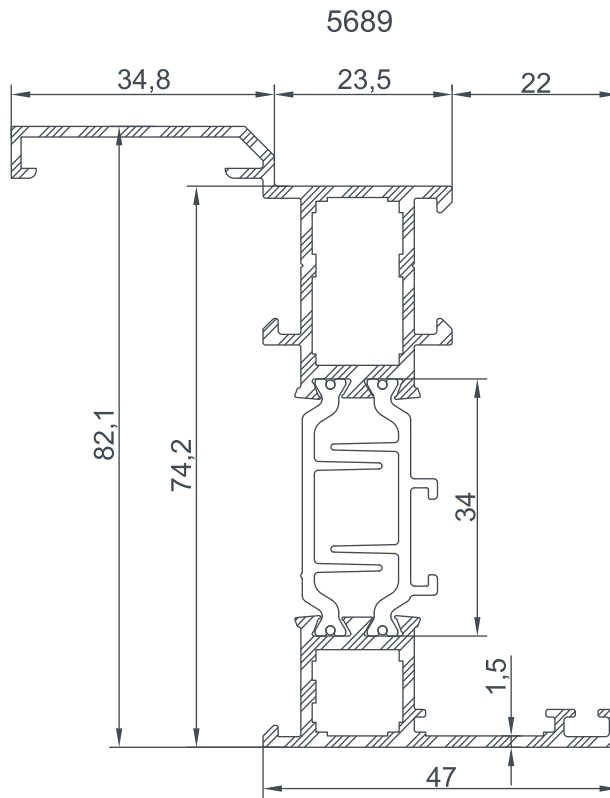

173





E 74

PROFILLER / PROFILES

COD Code	AGIRLIK (kg/m) Weight	Jxx cm4	Jyy cm4	Wxx cm3	Wyy cm3	L m
5653	1,534	44,41	4,04	8,68	1,83	6
5503	1,628	48,33	4,25	9,37	1,90	6
5654	1,837	56,15	11,88	10,65	4,34	6
5504	1,966	61,76	12,93	11,77	4,73	6

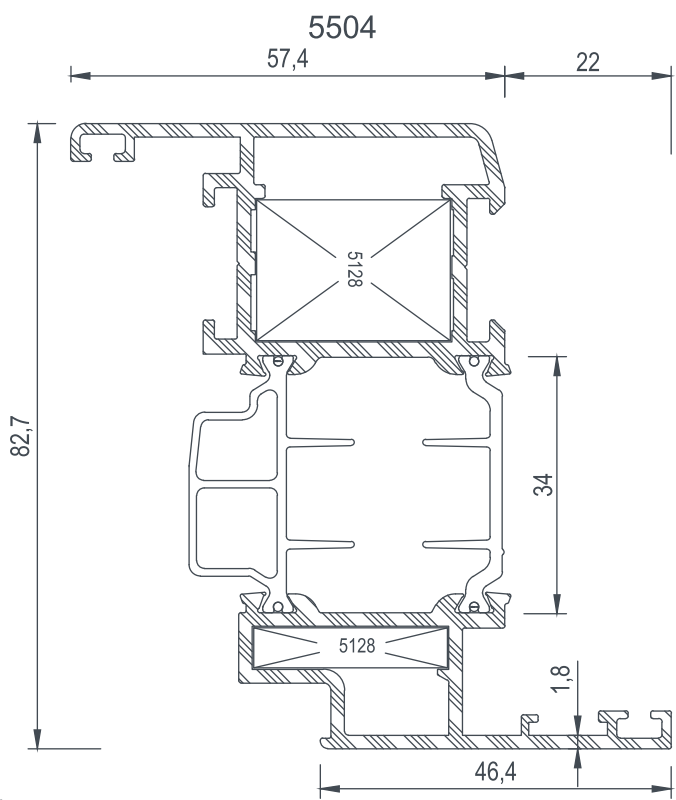
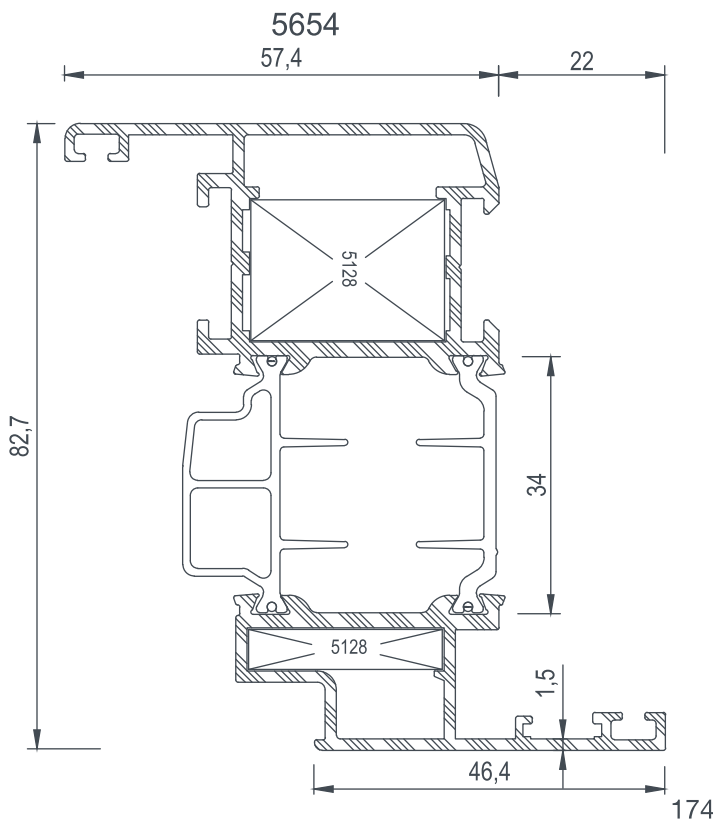
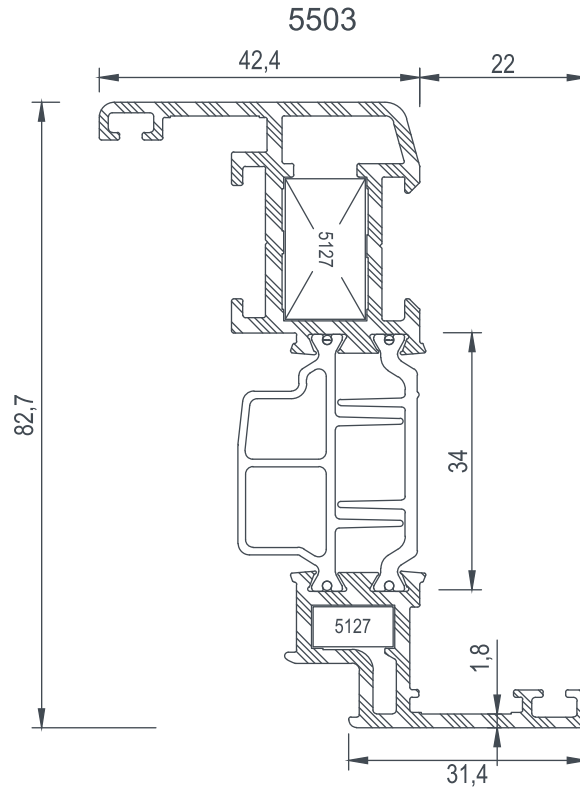
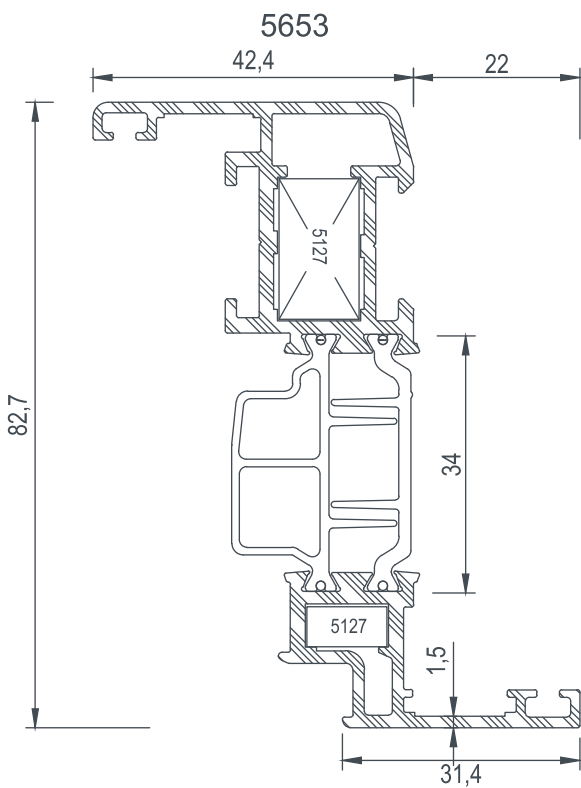



E 74

PROFILLER / PROFILES

COD Code	AGIRLIK (kg/m) Weight	Jxx cm4	Jyy cm4	Wxx cm3	Wyy cm3	L m
5670	2,010	64,77	12,36	12,02	4,57	6
5655	1,777	53,66	9,84	10,05	3,62	6
5656	2,246	75,82	27,31	12,75	6,96	6

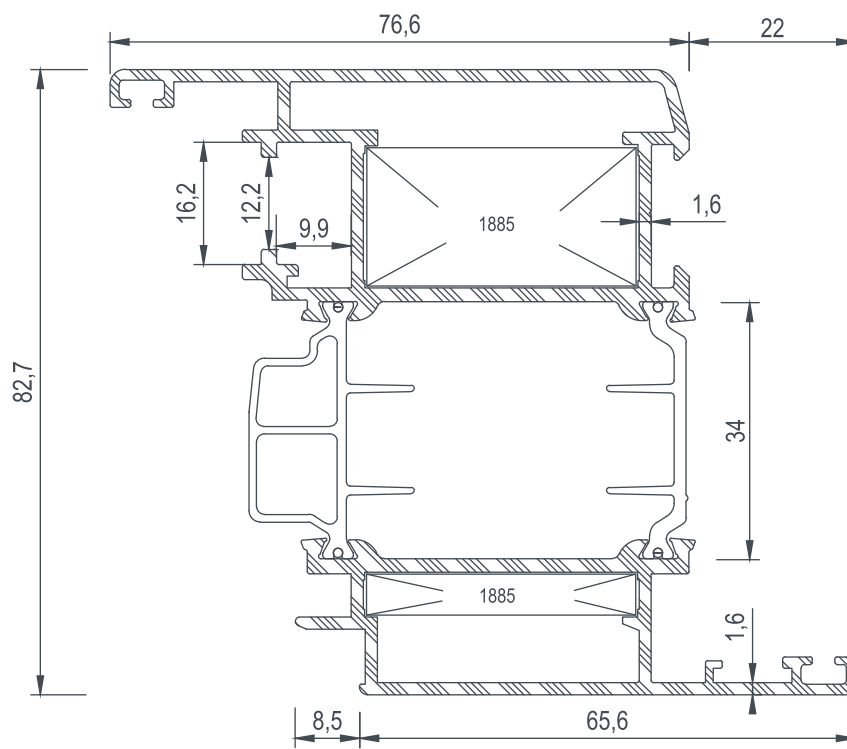
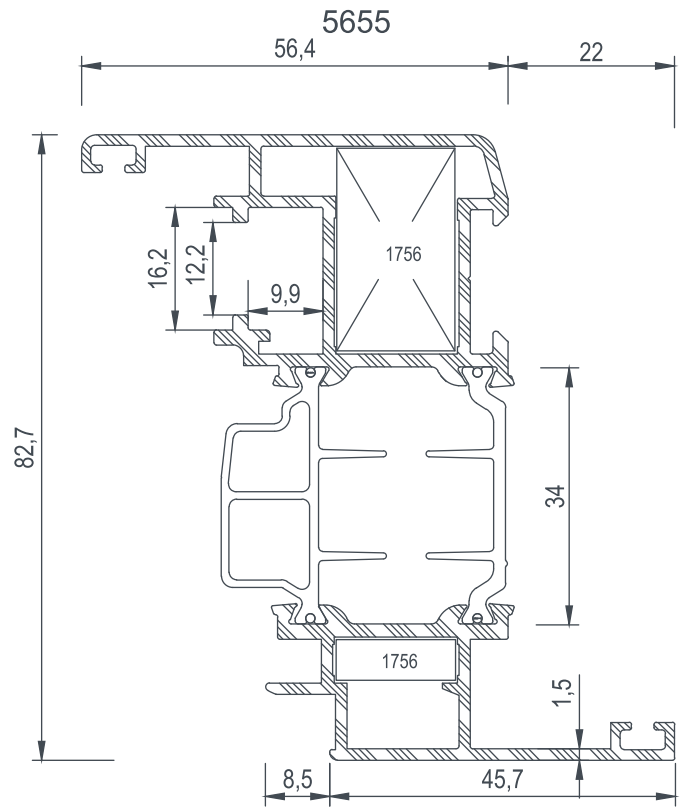
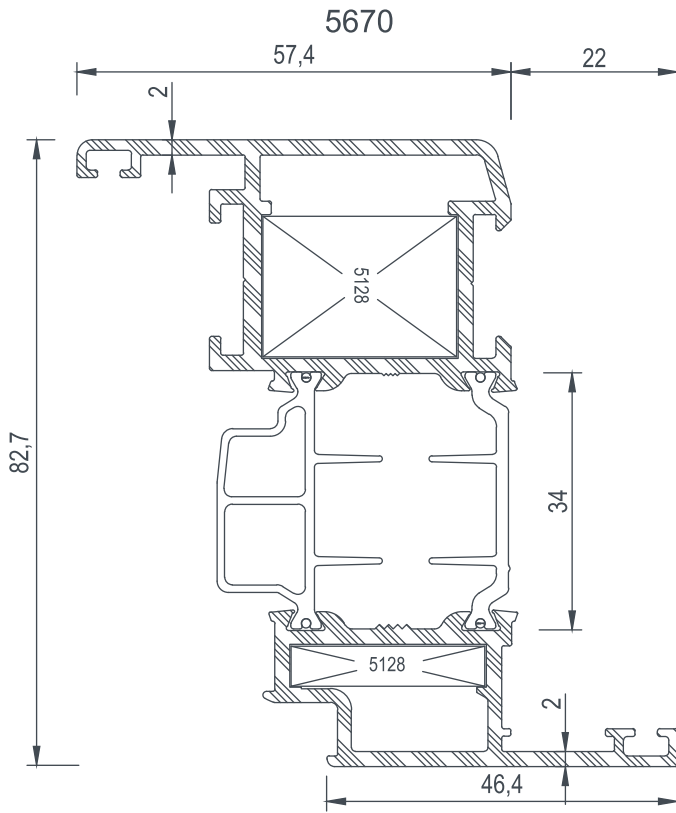

5656

175

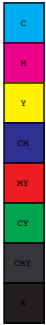



E 74

PROFILLER / PROFILES

COD Code	AGIRLIK (kg/m) Weight	Jxx cm4	Jyy cm4	Wxx cm3	Wyy cm3	L m
5556	2,187	71,32	18,76	12,84	5,90	6
5671	2,041	67,61	12,77	12,74	4,46	6
5557	2,755	99,70	51,04	15,06	10,55	6

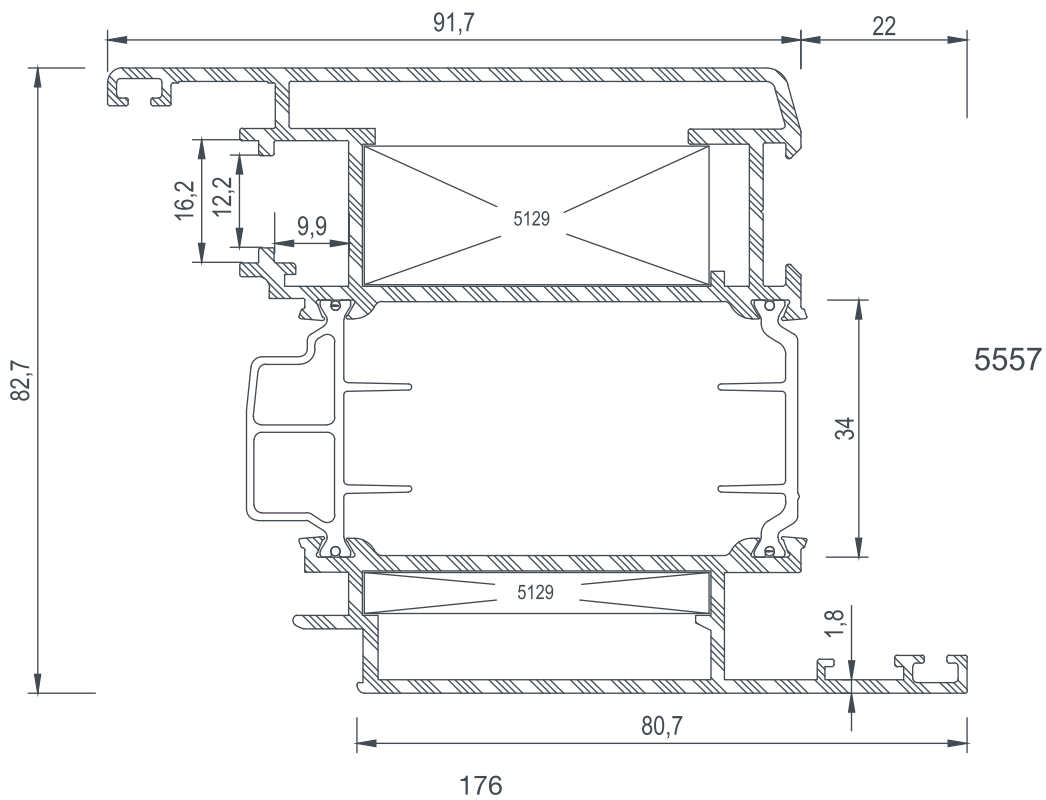
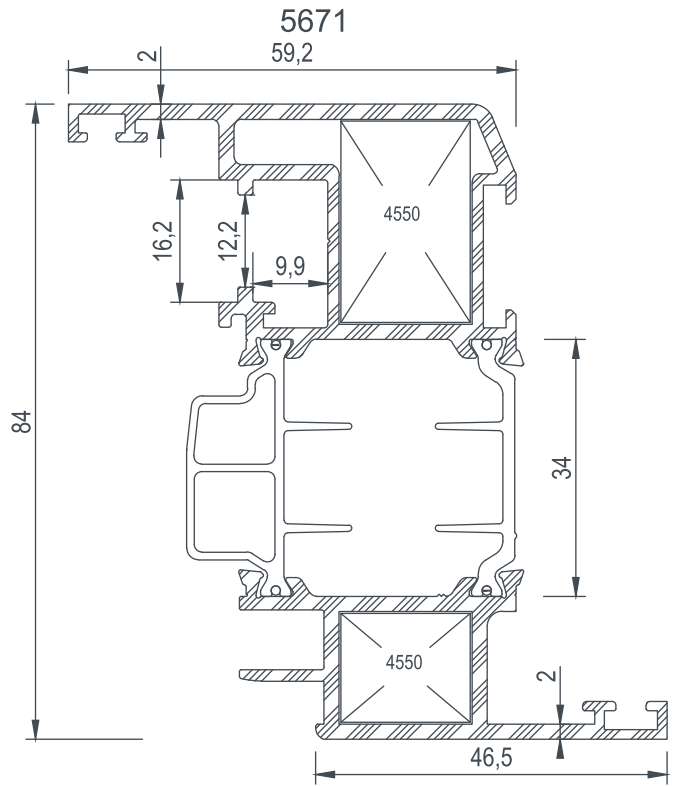
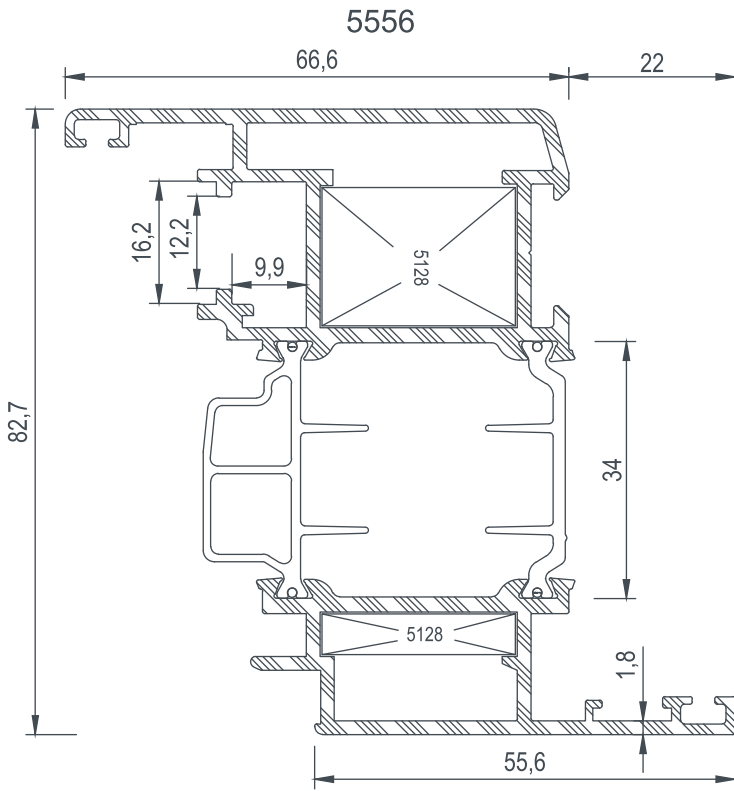



E 74

PROFİLLER / PROFILES

COD Code	AGIRLIK (kg/m) Weight	Jxx cm4	Jyy cm4	Wxx cm3	Wyy cm3	L m
5657	2,515	90,08	48,00	13,32	9,36	6
5558	2,680	97,83	52,43	14,60	10,38	6

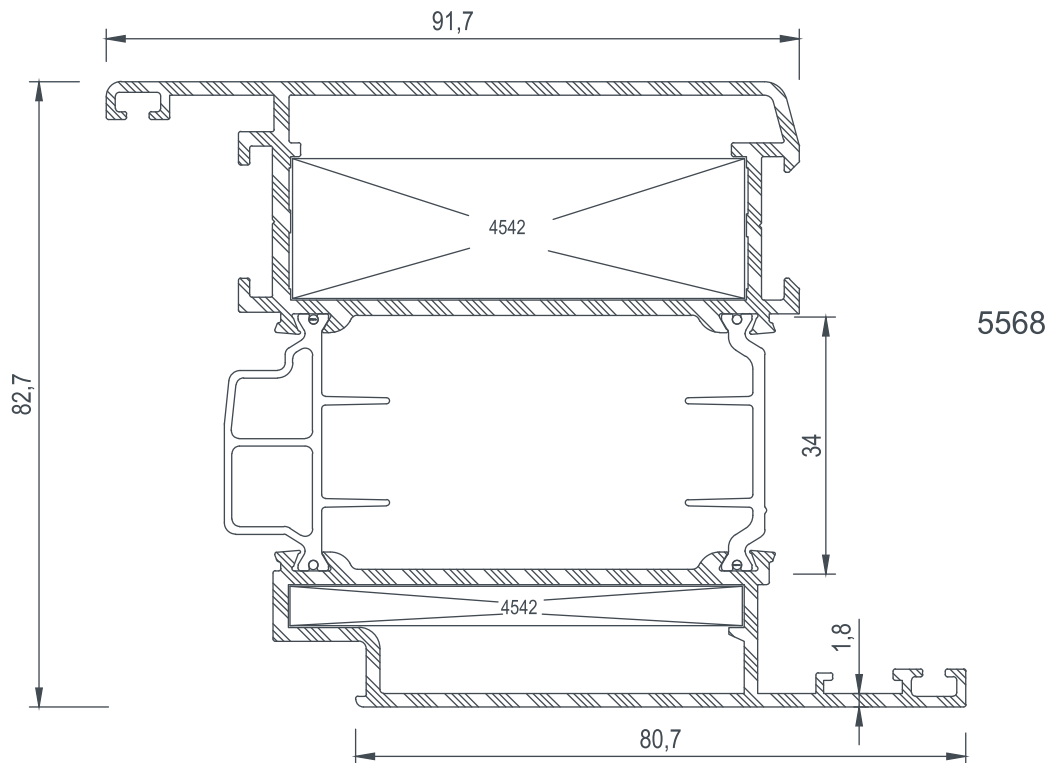
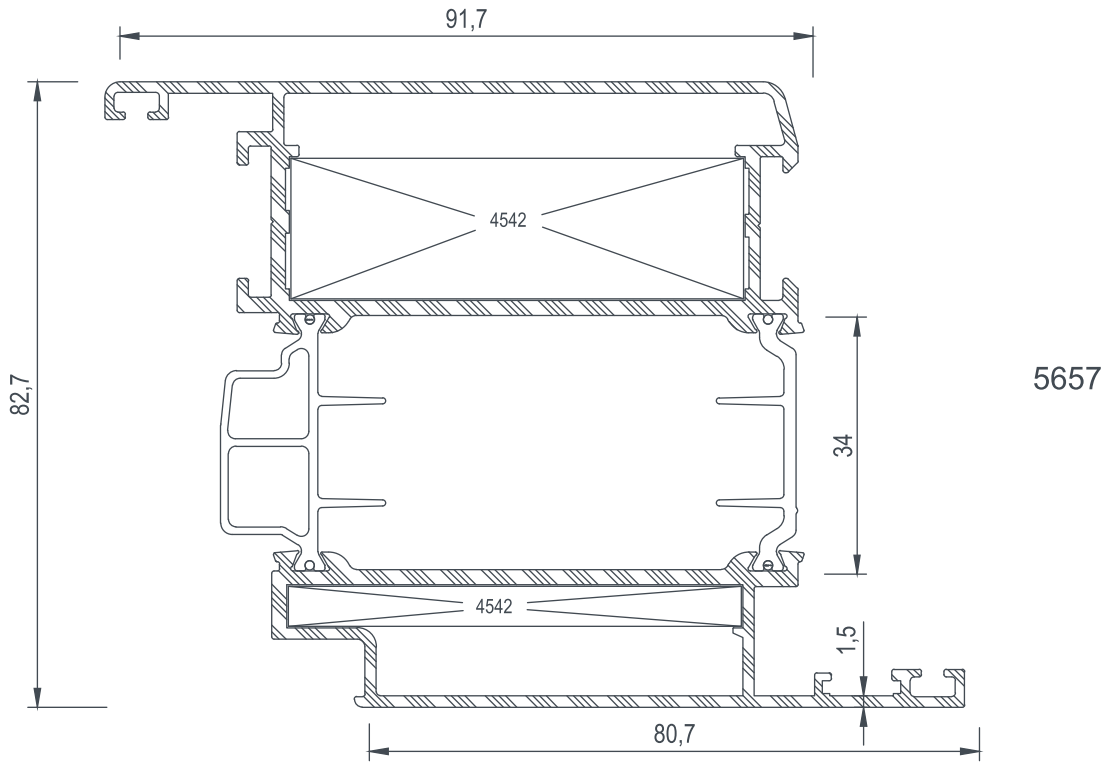



E 74

PROFILLER / PROFILES

COD Code	AGIRLIK (kg/m) Weight	Jxx cm ⁴	Jyy cm ⁴	Wxx cm ³	Wyy cm ³	L m
5672	2,759	104,17	52,28	15,60	10,60	6

5672

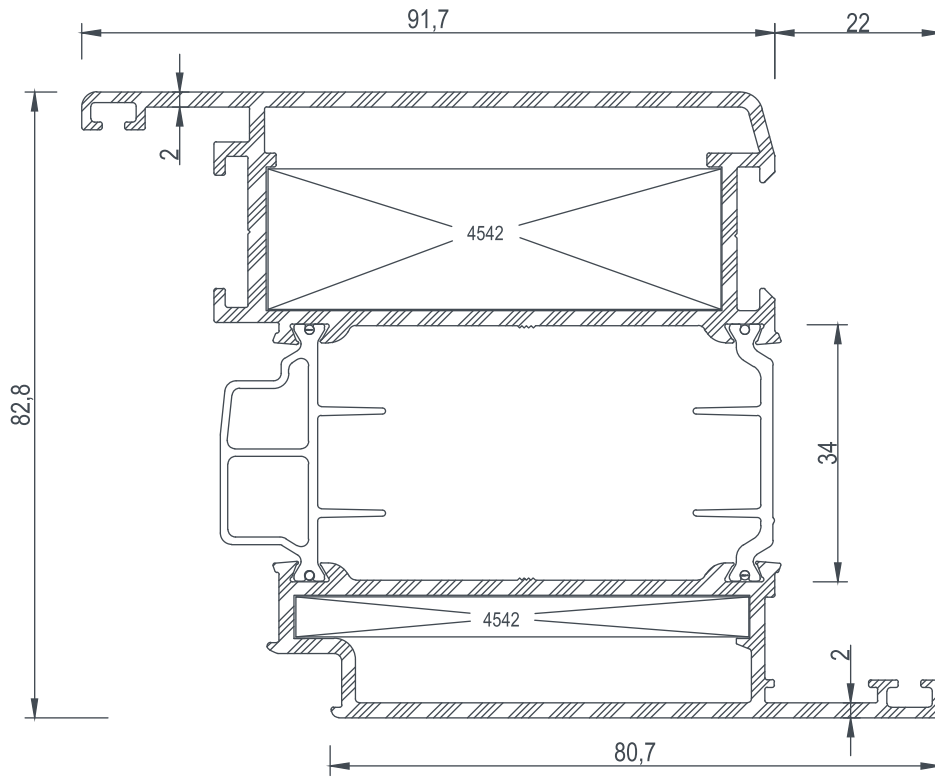



E 74

PROFILLER / PROFILES

COD Code	AGIRLIK (kg/m) Weight	Jxx cm4	Jyy cm4	Wxx cm3	Wyy cm3	L m
5658	2,308	64,87	44,36	13,74	8,79	6
5506	2,490	72,70	48,31	15,42	9,51	6

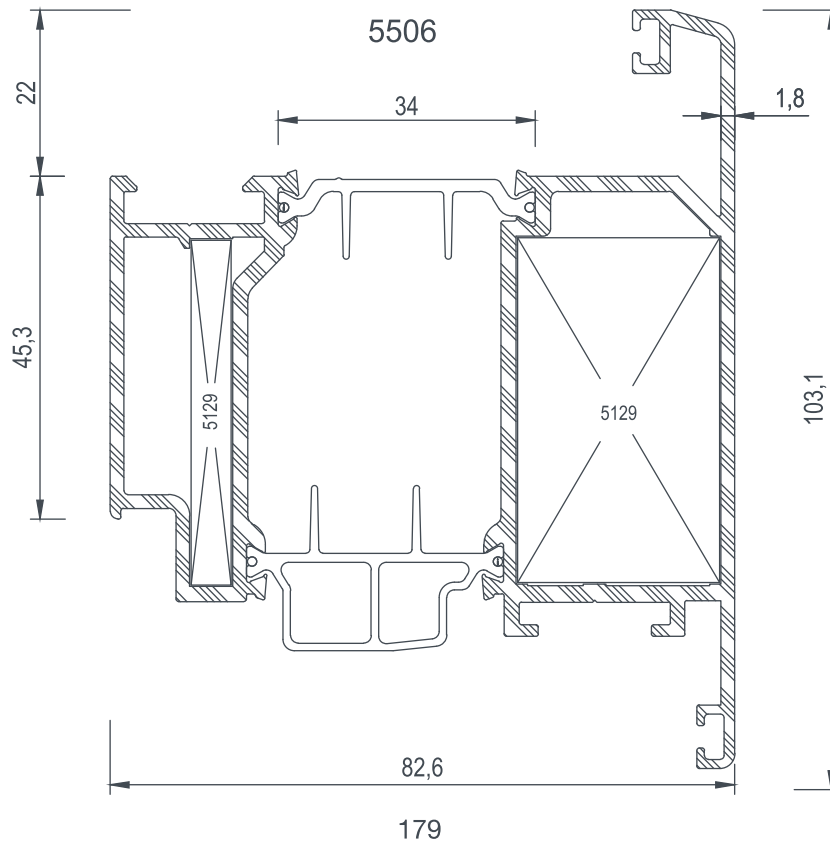
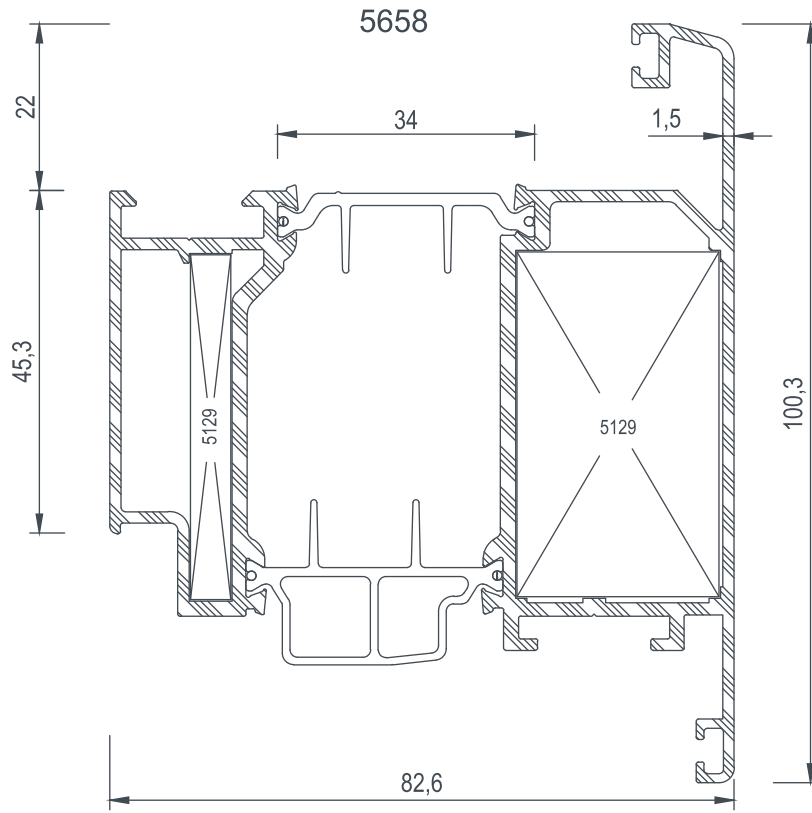



E 74

PROFILLER / PROFILES

COD Code	AGIRLIK (kg/m) Weight	Jxx cm4	Jyy cm4	Wxx cm3	Wyy cm3	L m
5659	1,403	33,31	7,63	7,60	2,21	6
5507	1,472	35,71	7,96	8,15	2,30	6
5660	1,716	41,62	16,53	9,67	3,93	6
5508	1,812	45,21	17,37	10,51	4,13	6

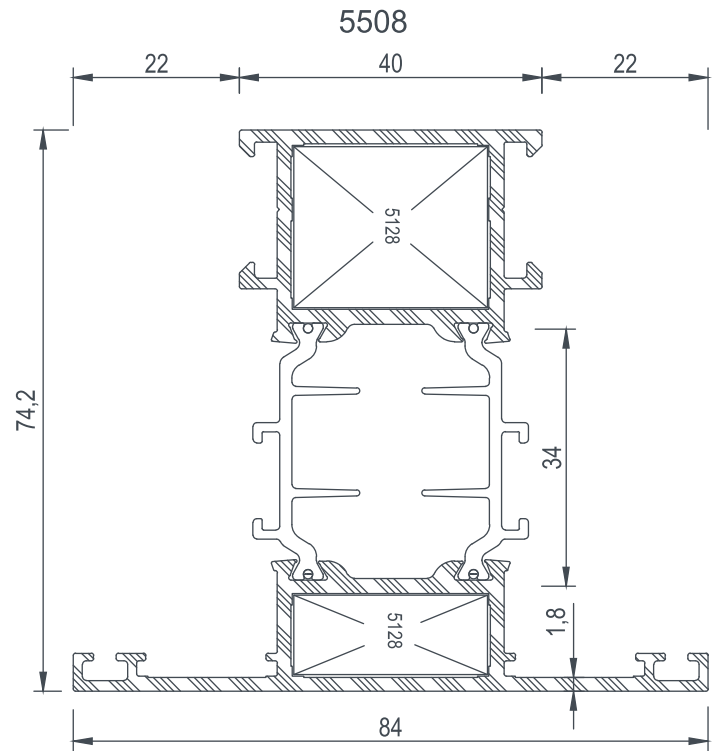
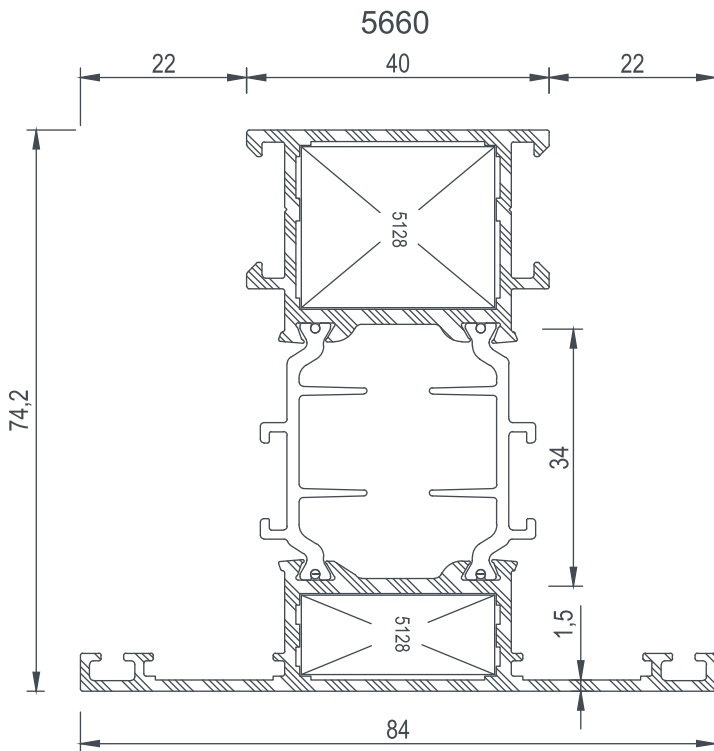
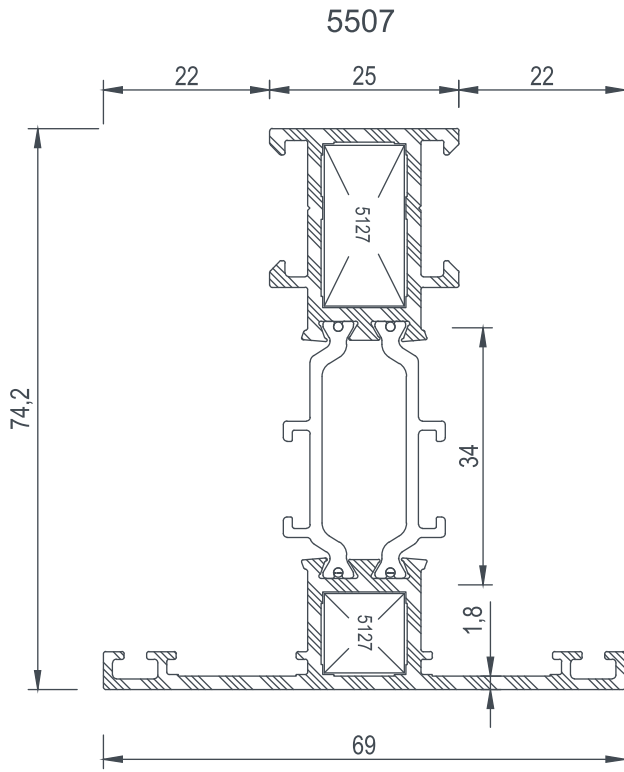
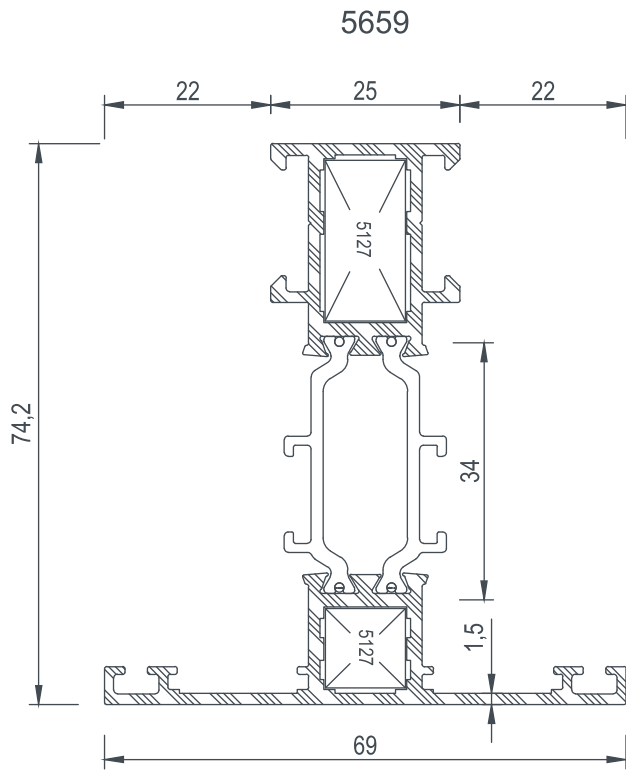



E 74

PROFILLER / PROFILES

COD Code	AGIRLIK (kg/m) Weight	Jxx cm4	Jyy cm4	Wxx cm3	Wyy cm3	L m
5673	1,881	66,56	22,18	16,43	5,28	6
5662	1,795	44,48	16,90	10,74	4,02	6
5510	1,885	52,30	37,77	12,31	7,26	6

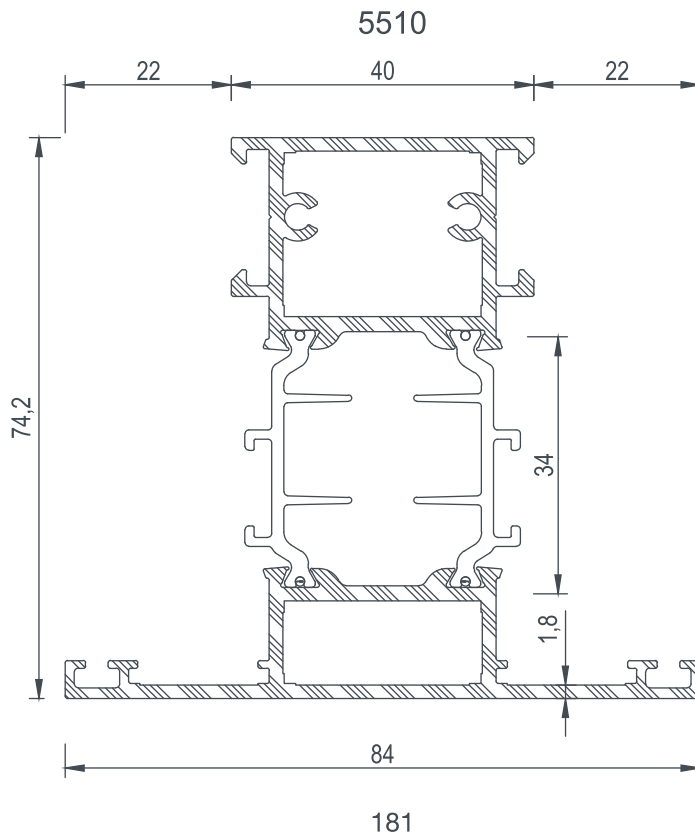
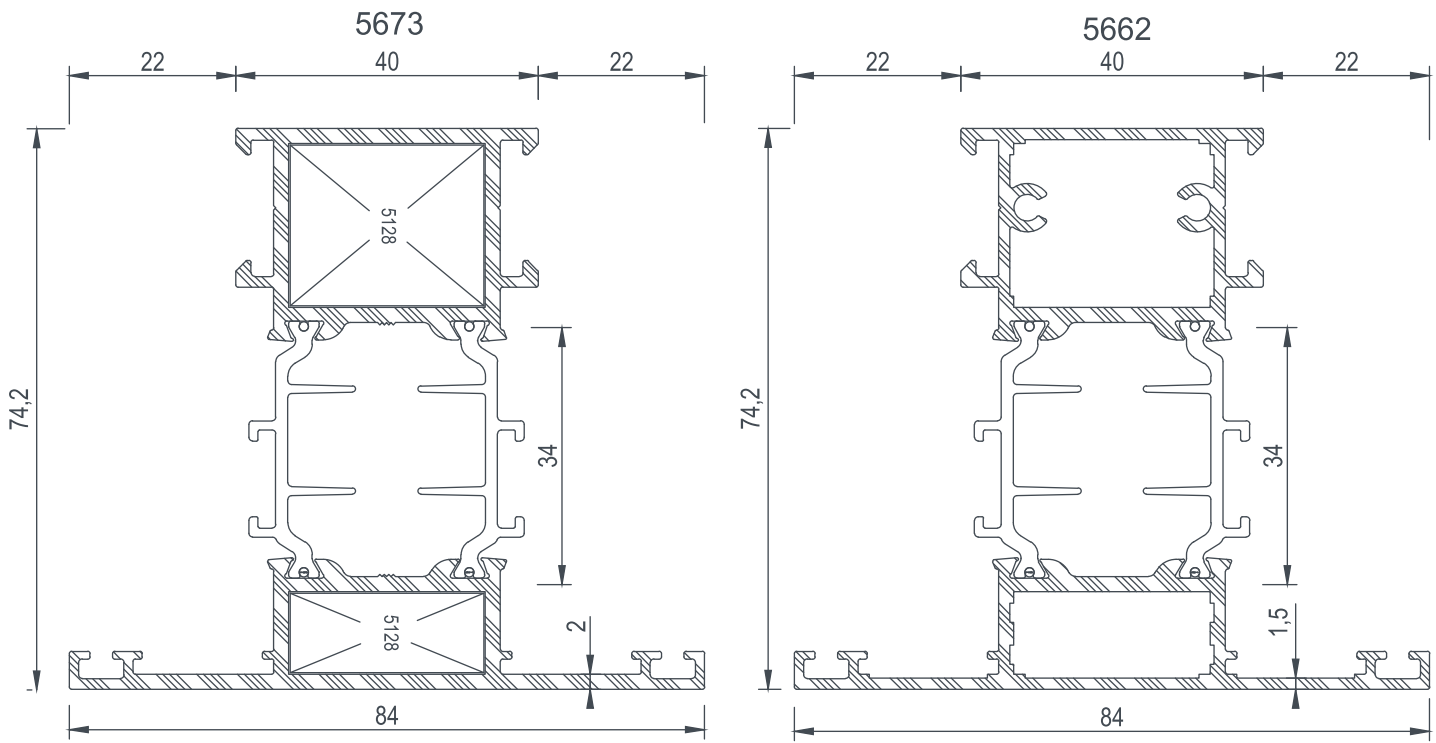



E 74

PROFILLER / PROFILES

COD Code	AGIRLIK (kg/m) Weight	Jxx cm4	Jyy cm4	Wxx cm3	Wyy cm3	L m
5661	2,098	52,30	37,77	12,31	7,26	6
5509	2,224	57,40	39,90	13,56	7,67	6

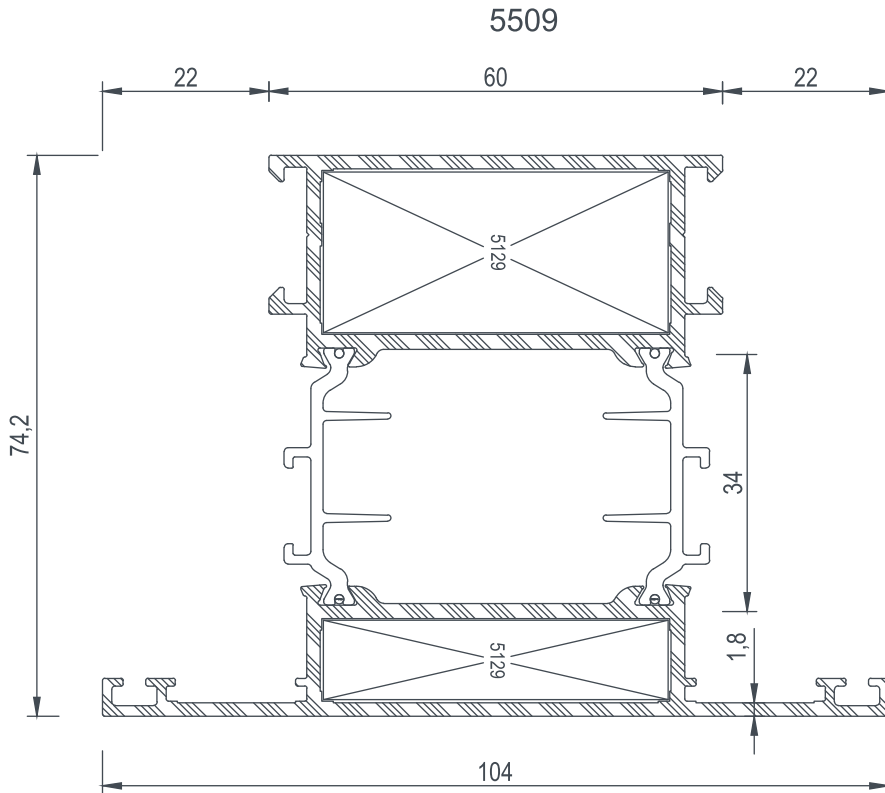
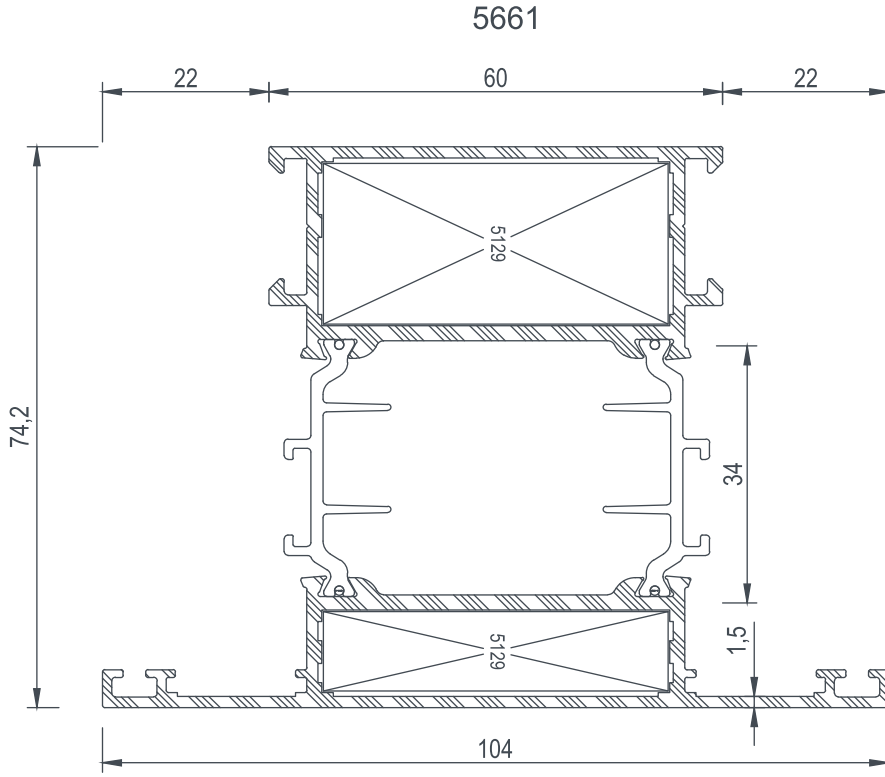

182





E 74

PROFİLLER / PROFILES

COD Code	AGIRLIK (kg/m) Weight	Jxx cm4	Jyy cm4	Wxx cm3	Wyy cm3	L m
5663	2,316	110,91	26,66	17,83	6,34	6
5511	2,526	125,24	29,33	19,73	6,98	6

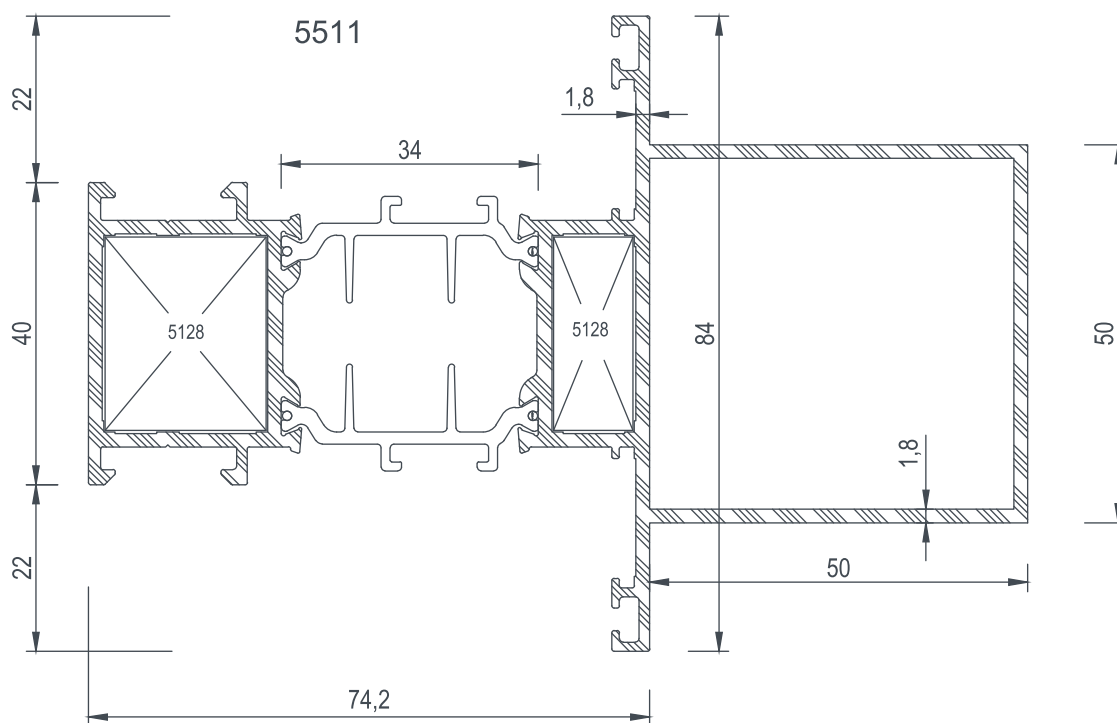
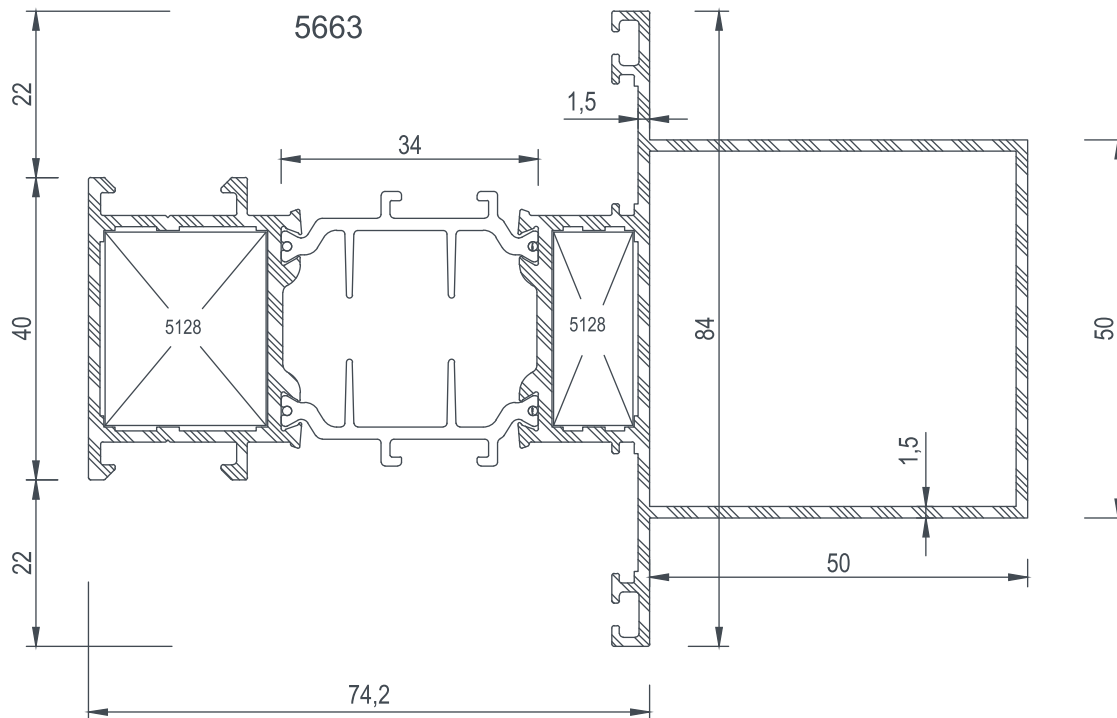



E 74

PROFILLER / PROFILES

COD Code	AGIRLIK (kg/m) Weight	Jxx cm ⁴	Jyy cm ⁴	Wxx cm ³	Wyy cm ³	L m
5664	2,509	160,67	24,50	7,60	2,21	6
5512	2,728	177,13	26,77	21,14	6,37	6

5664

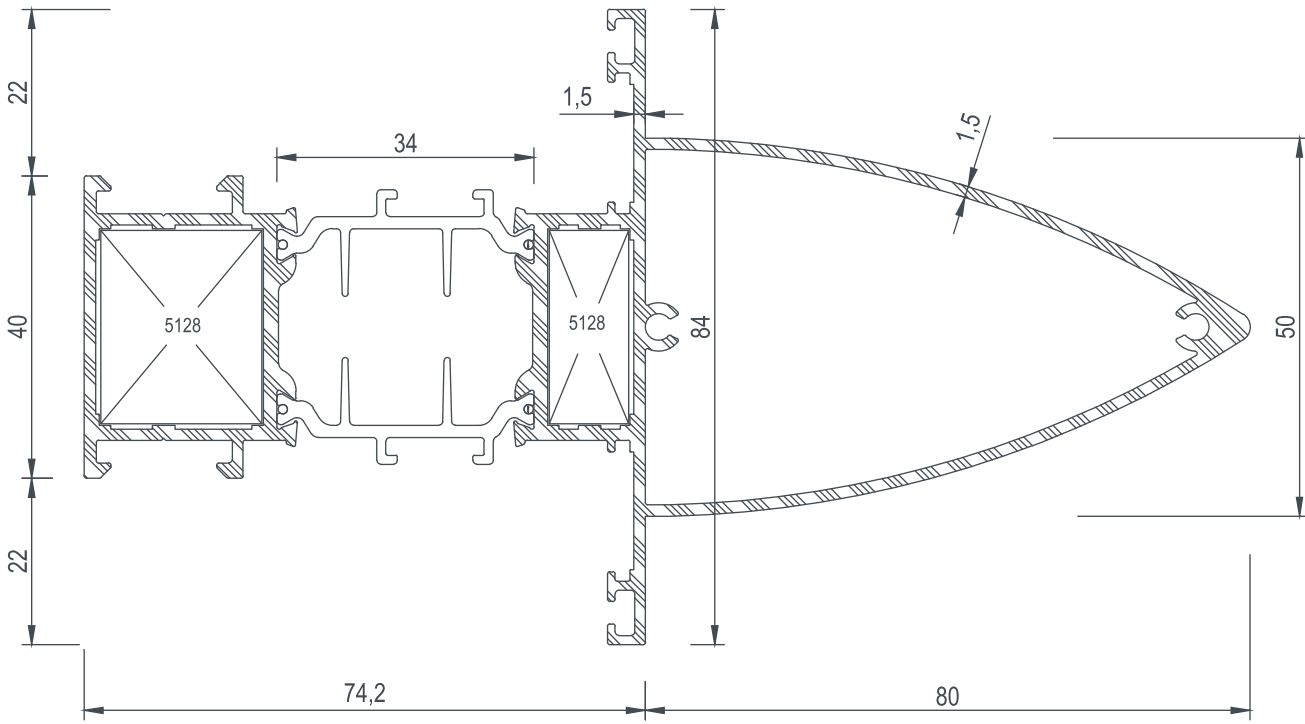

5512

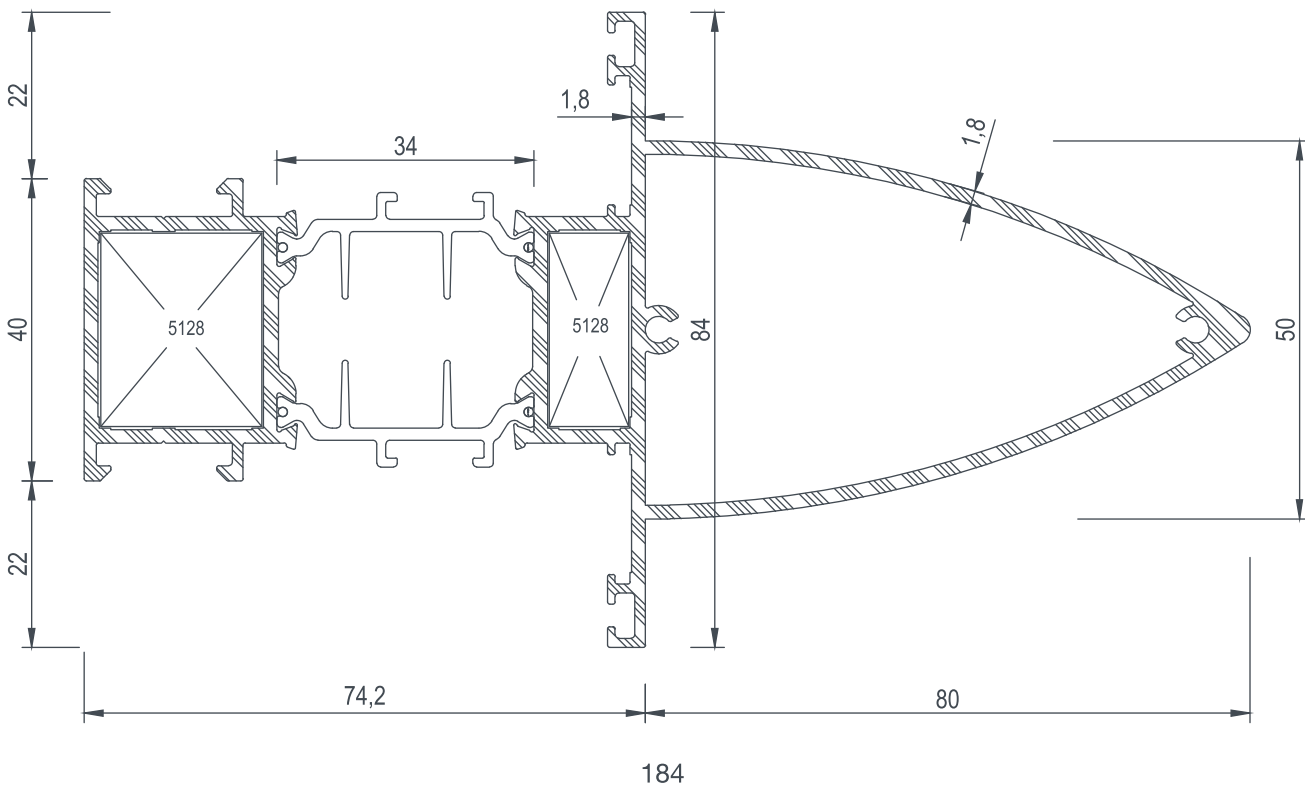



E 74

PROFİLLER / PROFILES

COD Code	AGIRLIK (kg/m) Weight	Jxx cm4	Jyy cm4	Wxx cm3	Wyy cm3	L m
5665	2,478	81,00	62,22	11,00	10,46	6
5513	2,669	89,43	69,49	12,22	11,41	6

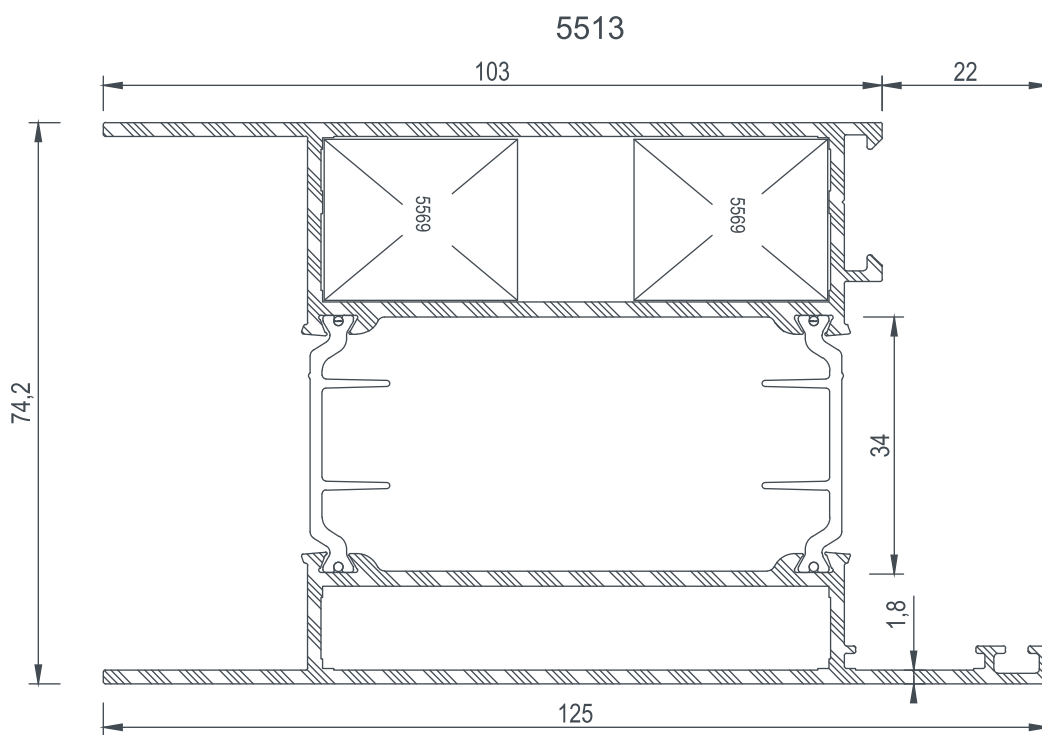
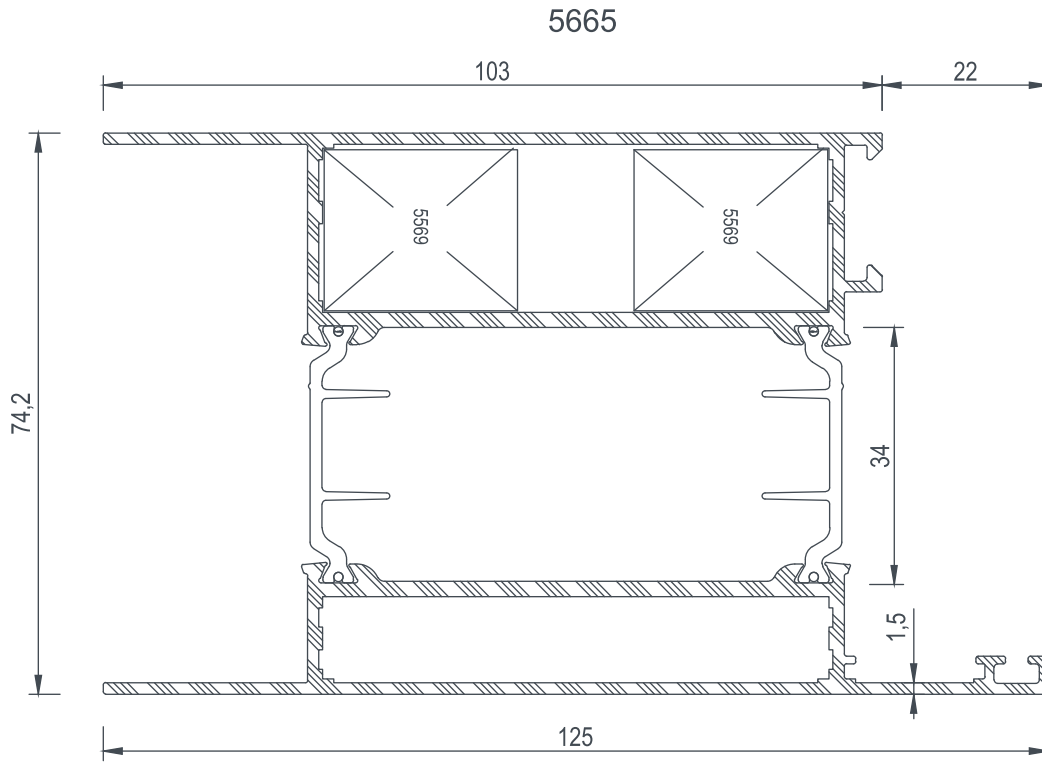

185





E 74

PROFILLER / PROFILES

COD Code	AGIRLIK (kg/m) Weight	Jxx cm ⁴	Jyy cm ⁴	Wxx cm ³	Wyy cm ³	L m
5678	2,834	95,24	74,43	13,07	12,10	6
5666	1,472	33,31	7,63	7,11	2,22	6
5514	1,549	35,02	8,18	7,30	2,34	6

5678

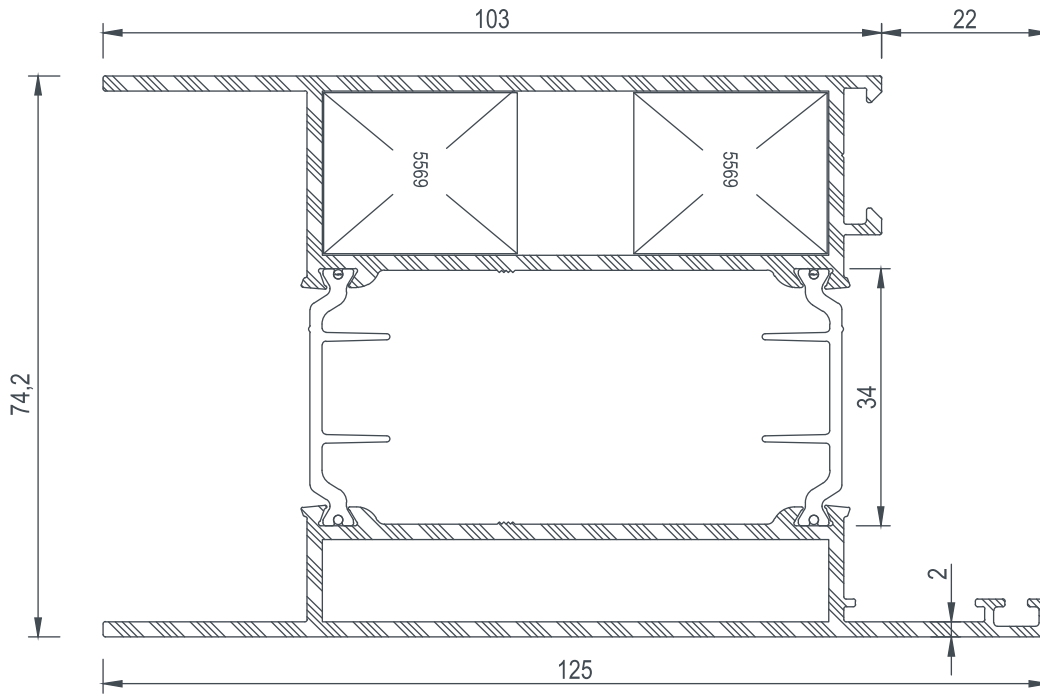

5666

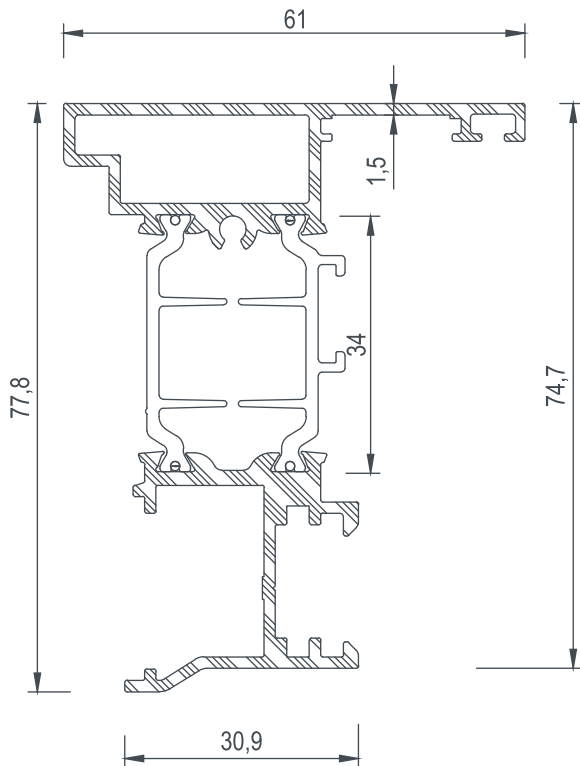

5514

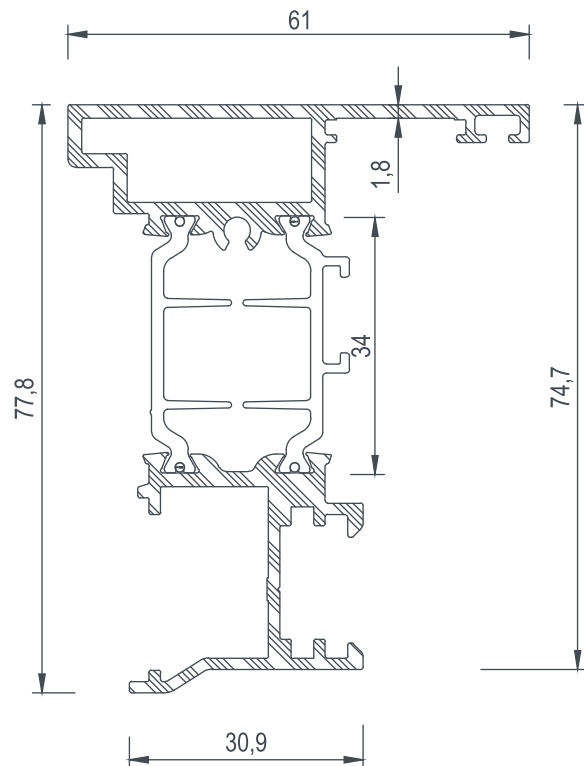



E 74

PROFİLLER / PROFILES

COD Code	AGIRLIK (kg/m) Weight	Jxx cm ⁴	Jyy cm ⁴	Wxx cm ³	Wyy cm ³	L m
5667	1,516	34,33	9,42	7,50	3,08	6
5515	1,625	37,84	10,37	8,28	3,31	6
5558	1,288	27,10	5,46	6,53	1,84	6
5117	0,105	----	----	----	----	6
5572	0,100	----	----	----	----	6

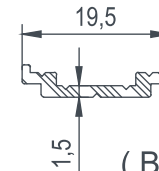
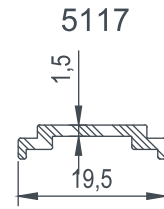
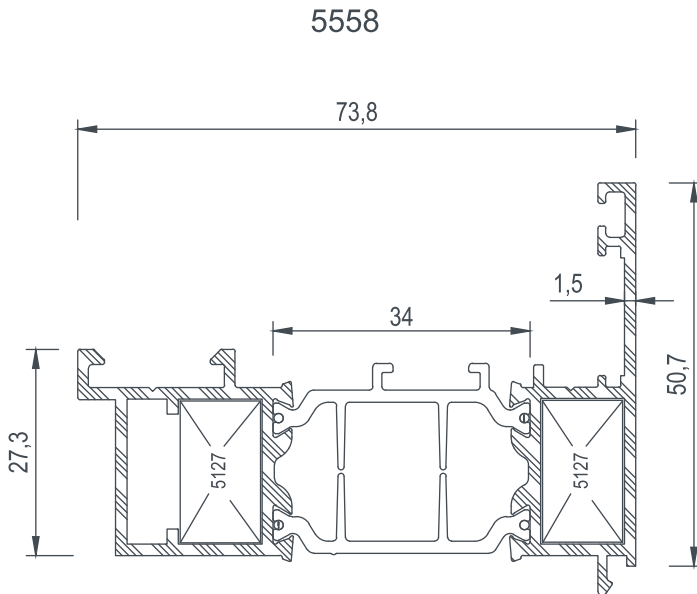
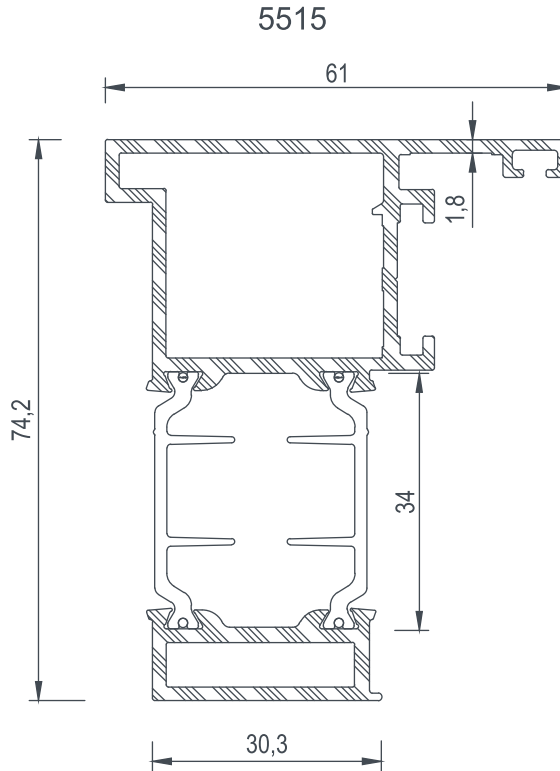
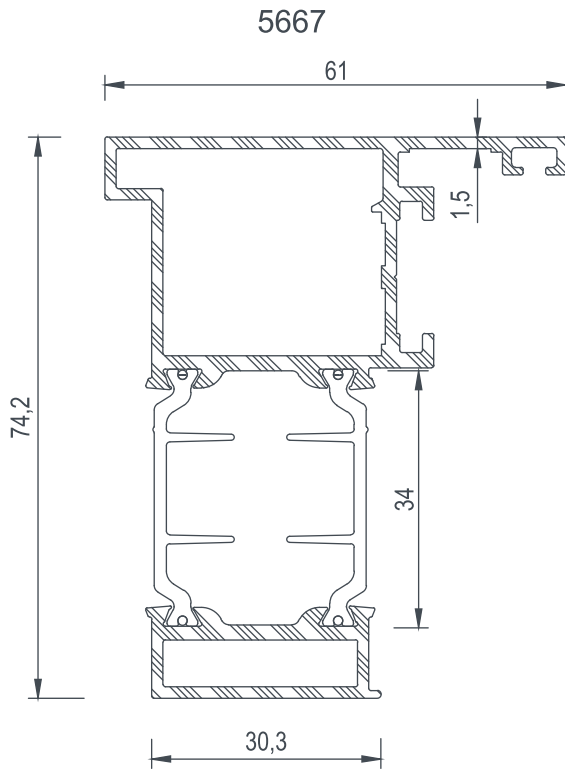

5572
(BOYALI TİJ PROFİLİ)

187





E 74

PROFILLER / PROFILES

COD Code	AGIRLIK (kg/m) Weight	Jxx cm ⁴	Jyy cm ⁴	Wxx cm ³	Wyy cm ³	L m
5516	2,151	61,14	40,77	10,82	7,78	6
5559	0,324	3,28	0,16	1,07	0,20	6
5560	1,674	25,92	25,21	7,00	7,10	6
5561	0,471	11,47	0,56	2,67	0,37	6
5337	0,151	---	---	---	---	6
5505	1,320	33,62	9,16	7,03	2,10	6

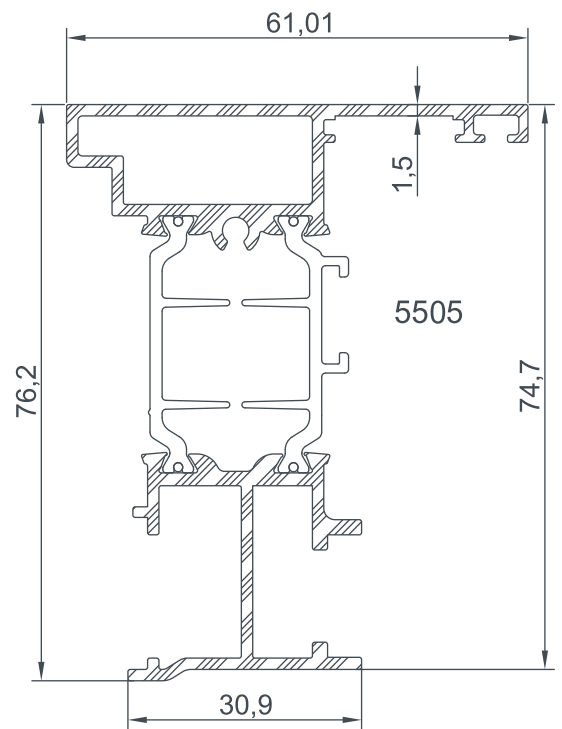
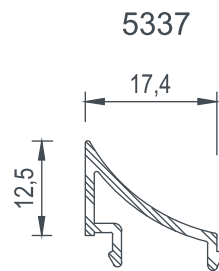
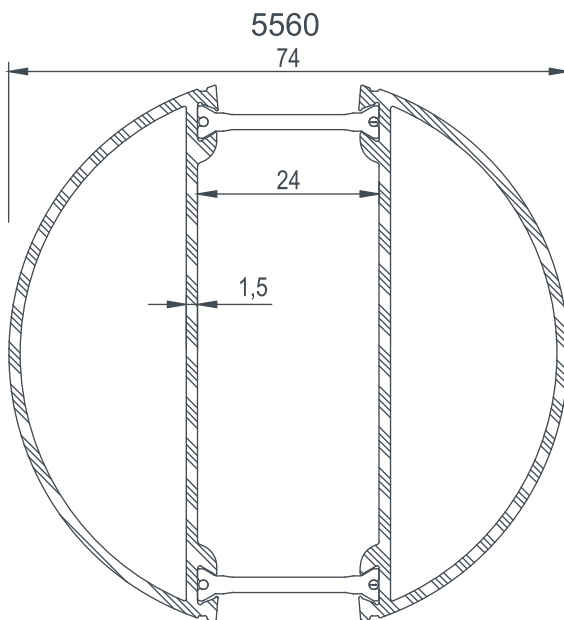
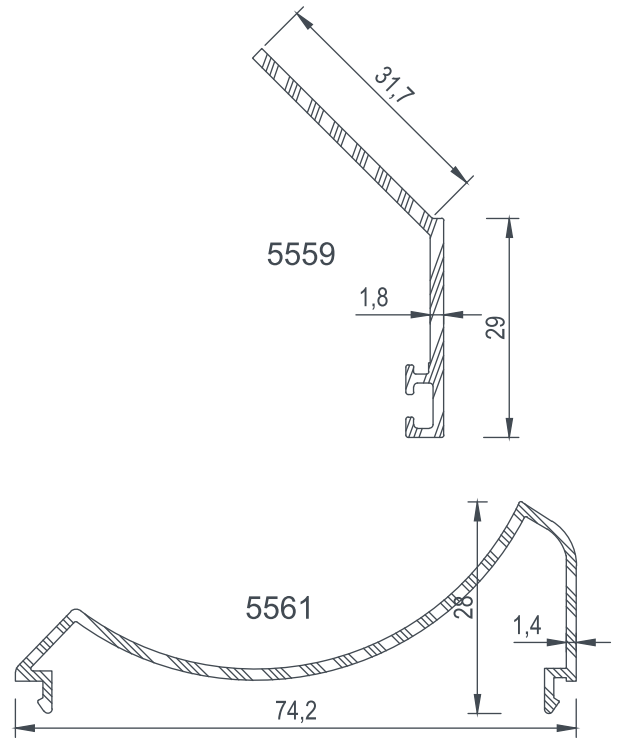
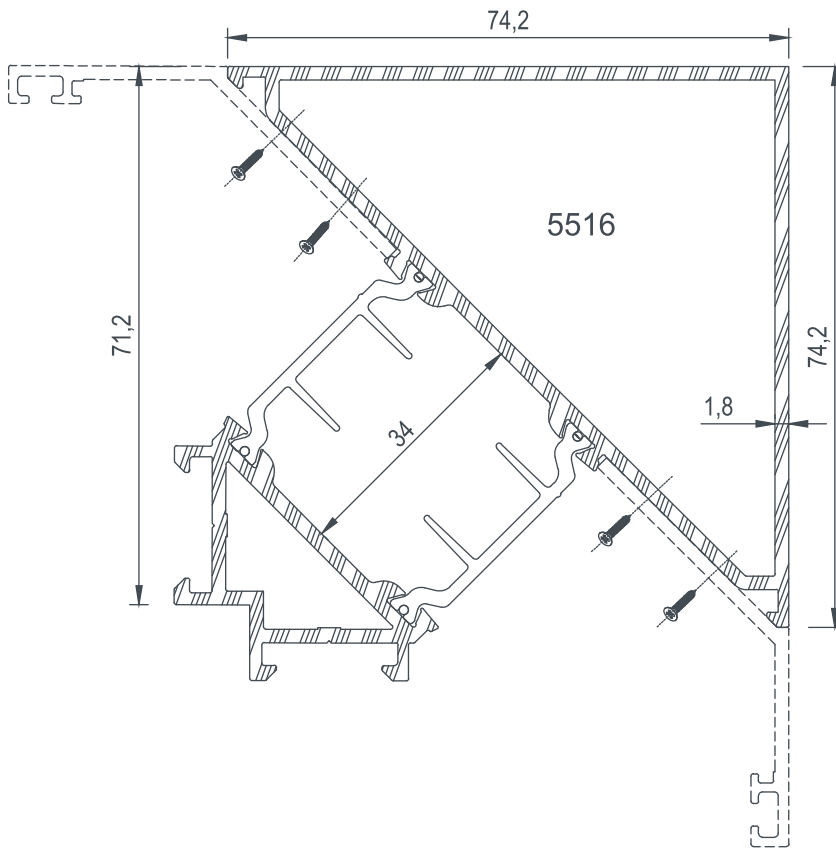



E 74

PROFİLLER / PROFILES

COD Code	AGIRLIK (kg/m) Weight	Jxx cm4	Jyy cm4	Wxx cm3	Wyy cm3	L m
5118	0,249	-----	-----	-----	-----	6
5119	0,251	-----	-----	-----	-----	6
5120	0,254	-----	-----	-----	-----	6
5121	0,259	-----	-----	-----	-----	6
5122	0,267	-----	-----	-----	-----	6
5123	0,274	-----	-----	-----	-----	6
5124	0,281	-----	-----	-----	-----	6
5125	0,292	-----	-----	-----	-----	6
5126	0,308	-----	-----	-----	-----	6
5535	0,305	-----	-----	-----	-----	6

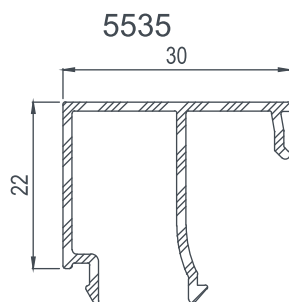
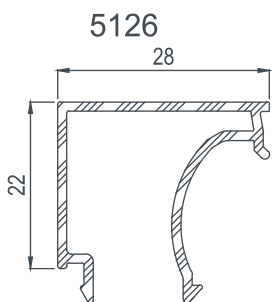
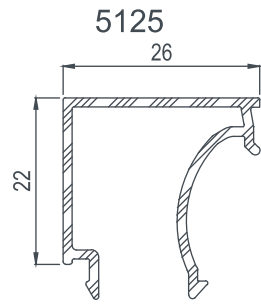
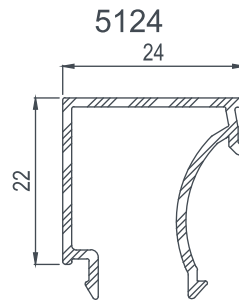
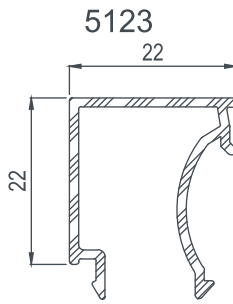
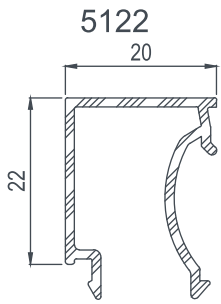
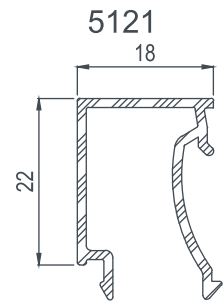
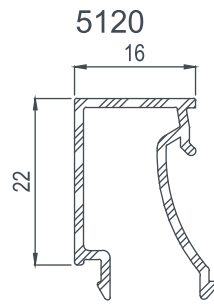
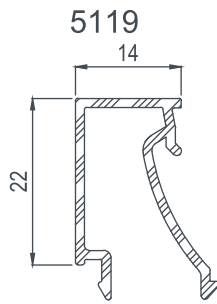
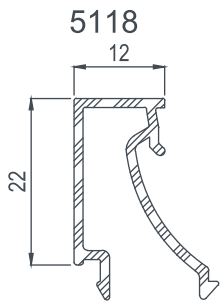

CAM ÇİTASI Glazing Bead	İÇ CAM FİTİLİ Glazing Gasket (in)	CAM KALINLIĞI Glas Thickness	DIŞ CAM FİTİLİ Glazing Gasket (out)
5118	E-01-027	40 mm	E-01-028
5119	E-01-027	38 mm	E-01-028
5120	E-01-027	36 mm	E-01-028
5121	E-01-027	34 mm	E-01-028
5122	E-01-027	32 mm	E-01-028
5123	E-01-027	30 mm	E-01-028
5124	E-01-027	28 mm	E-01-028
5125	E-01-027	26 mm	E-01-028
5126	E-01-027	24 mm	E-01-028
5535	E-01-027	22 mm	E-01-028



E 74

PROFİLLER / PROFILES

COD Code	AGIRLIK (kg/m) Weight	Jxx cm4	Jyy cm4	Wxx cm3	Wyy cm3	L m
5536	0,312	-----	-----	-----	-----	6
5537	0,318	-----	-----	-----	-----	6
5538	0,325	-----	-----	-----	-----	6
5539	0,331	-----	-----	-----	-----	6

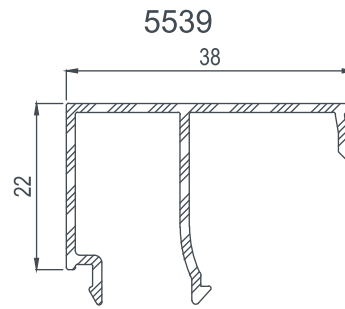
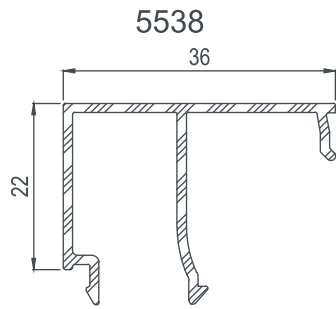
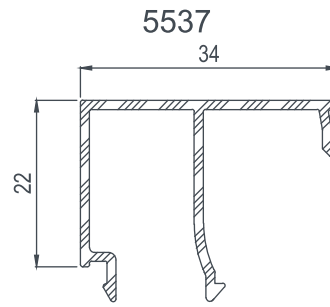
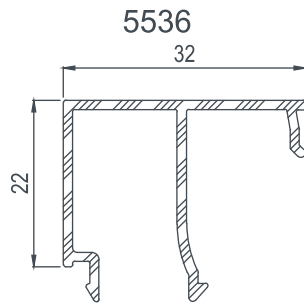

CAM ÇİTASI Glazing Bead	İÇ CAM FİTİLİ Glazing Gasket (in)	CAM KALINLIĞI Glas Thickness	DIŞ CAM FİTİLİ Glazing Gasket (out)
5536	E-01-027	20 mm	E-01-028
5537	E-01-027	18 mm	E-01-028
5538	E-01-027	16 mm	E-01-028
5539	E-01-027	14 mm	E-01-028

clarks

E 74

PROFİLLER

PROFILES

E 74 - 2.0T GİZLİ KANAT PROFİLİ
E 74 - 2.0T SECRET SASH PROFILE





E 74

PROFİLLER / PROFILES

COD Code	AGIRLIK (kg/m) Weight	Jxx cm4	Jyy cm4	Wxx cm3	Wyy cm3	L m
5674	2,223	72,89	56,06	9,78	11,33	6
5675	2,038	59,36	35,46	9,81	6,39	6

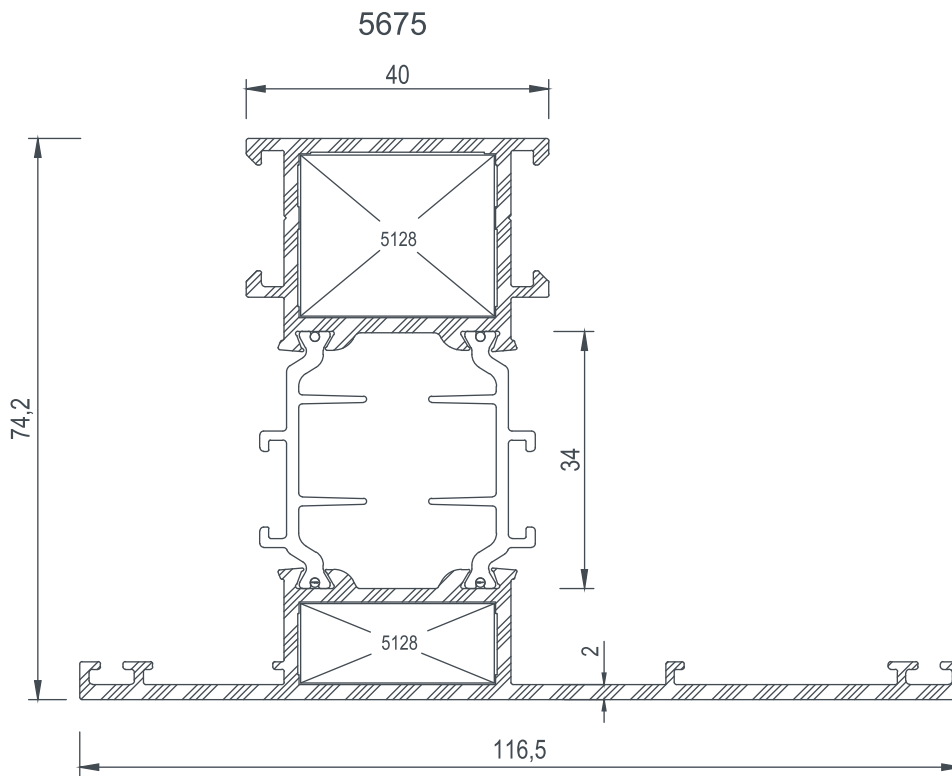
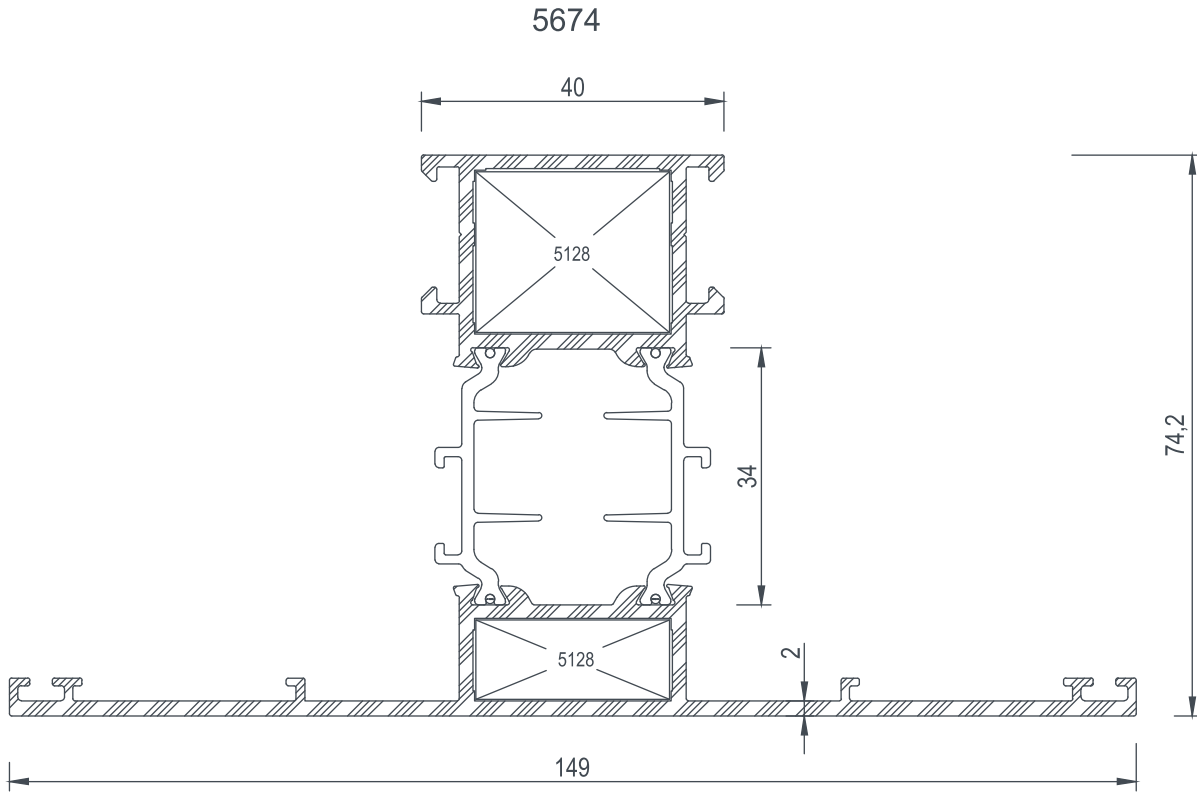

193





E 74

PROFİLLER / PROFILES

COD Code	AGIRLIK (kg/m) Weight	Jxx cm4	Jyy cm4	Wxx cm3	Wyy cm3	L m
5676	1,873	59,27	22,18	9,84	5,33	6
5677	1,570	40,24	5,84	8,83	2,31	6

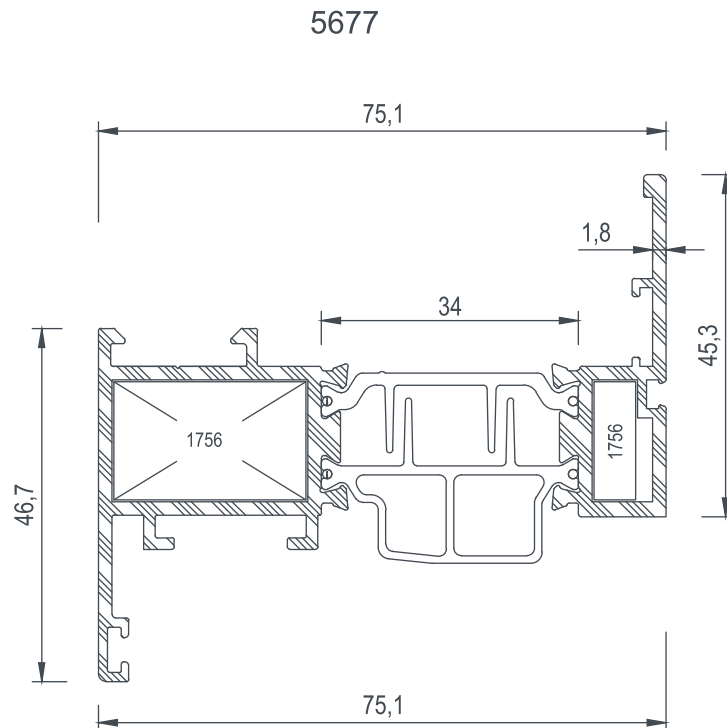
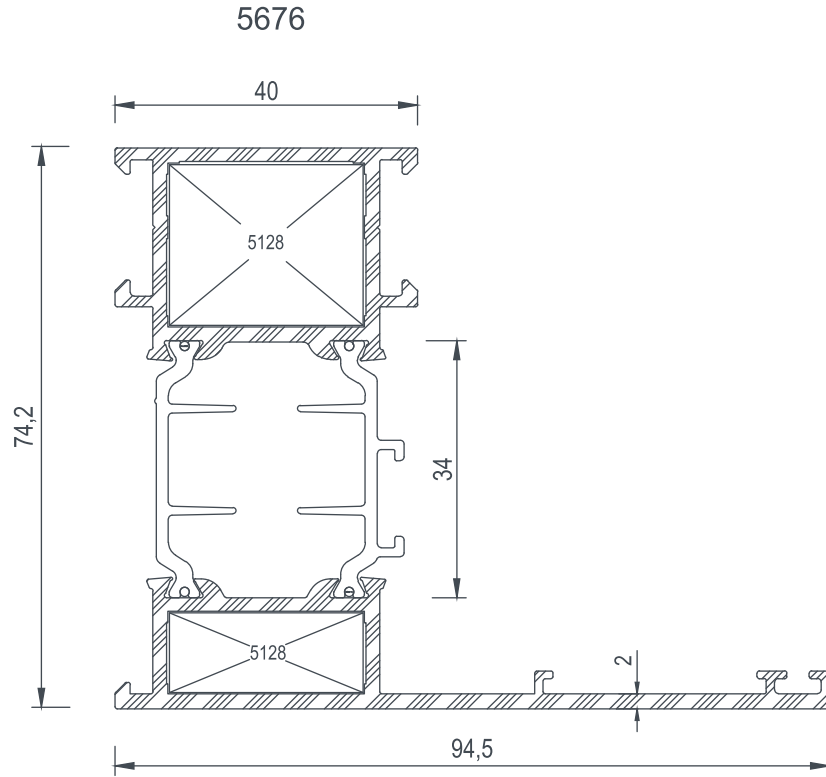



E 74

PROFİLLER / PROFILES

COD Code	AGIRLIK (kg/m) Weight	Jxx cm4	Jyy cm4	Wxx cm3	Wyy cm3	L m
5587	0,510	6,36	0,82	1,97	0,75	6
5588	0,521	6,63	1,05	2,00	0,90	6
5589	0,548	7,30	1,18	2,11	0,73	6
5590	0,542	7,13	1,08	2,08	0,73	6
5591	0,534	6,97	1,00	2,06	0,74	6
5592	0,554	7,47	1,30	2,14	0,74	6
5593	0,560	7,65	1,41	2,17	0,76	6
5594	0,567	7,83	1,55	2,20	0,78	6
5595	0,573	8,02	1,70	2,23	0,81	6

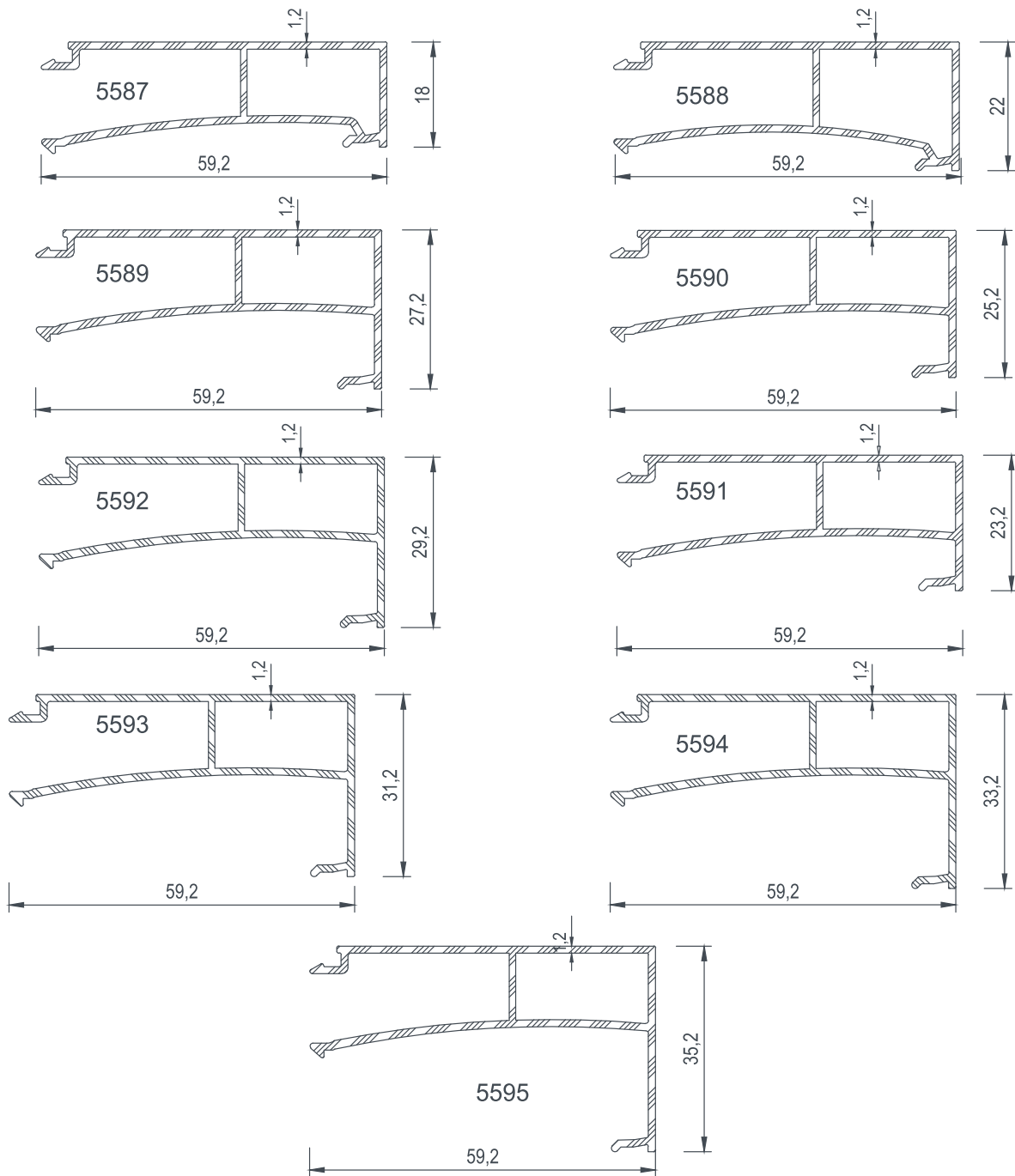

SCALE BY 1/10







E 74

PROFİLLER / PROFILES

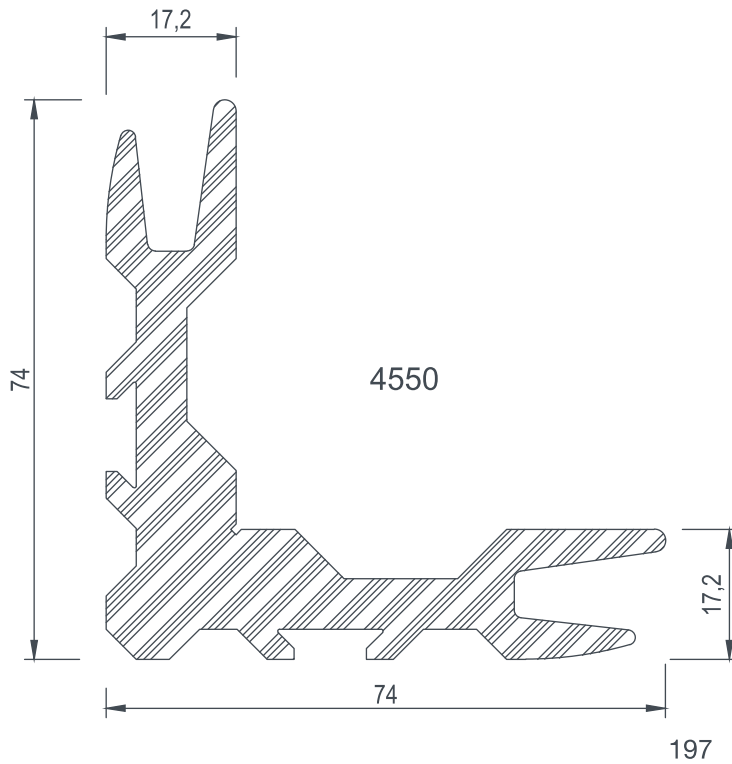
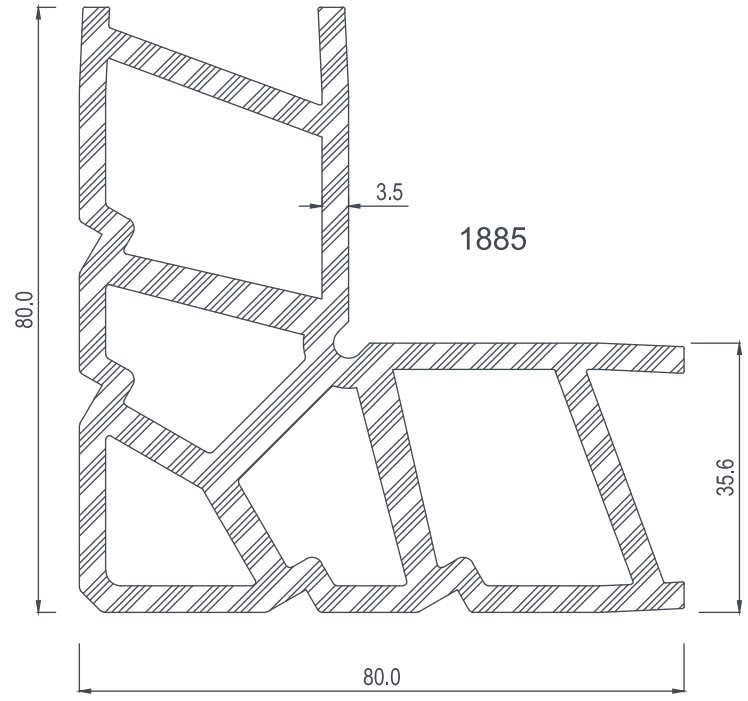
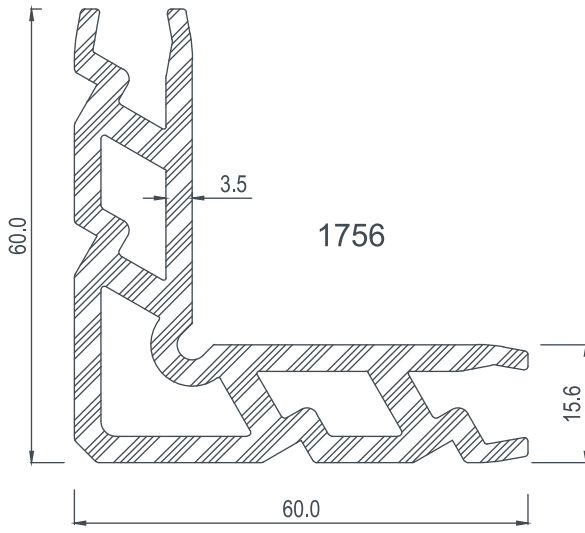
COD Code	AGIRLIK (kg/m) Weight	Jxx cm4	Jyy cm4	Wxx cm3	Wyy cm3	L m
1756	2,474	---	---	---	---	6
1885	4,471	---	---	---	---	6
4550	3,581	---	---	---	---	6



KÖŞE TAKOZLARI / Corner Cleats

Nr	 L m	AKS. KODU Acs. Code	KESİM ÖLÇÜSÜ Cutting Size
5655	1756	1756-26,8	26,8 mm
	1756	1756-5,4	5,4 mm
5677	1756	1756-25,4	25,4 mm
	1756	1756-5,5	5,5 mm
5656	1885	1885-18,3	18,3 mm
	1885	1885- 5,3	5,3 mm
5671	4550	4550-18,3	18,3 mm
	4550	4550- 5,3	5,3 mm



E 74

PROFİLLER / PROFILES

COD Code	AGIRLIK (kg/m) Weight	Jxx cm4	Jyy cm4	Wxx cm3	Wyy cm3	L m
5127	3,484	----	---	---	----	6

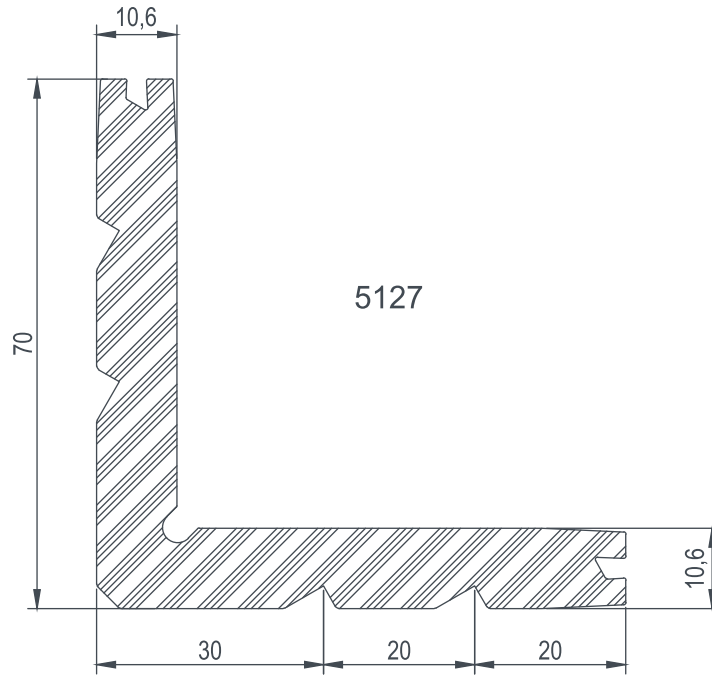

KÖŞE TAKOZLARI / Corner Cleats

Nr	 L m	AKS. KODU Ac. Code	KESİM ÖLÇÜSÜ Cutting Size
5650	5127	5127-21,3	21,3 mm
	5127	5127-10,5	10,5 mm
5653	5127	5127-18,6	18,6 mm
	5127	5127- 5,3	5,3 mm
5500	5127	5127-21,3	21,3 mm
	5127	5127-10,5	10,5 mm
5659	5127	5127-21,3	21,3 mm
	5127	5127-10,5	10,5 mm
5503	5127	5127-18,6	18,6 mm
	5127	5127- 5,3	5,3 mm
5507	5127	5127-21,3	21,3 mm
	5127	5127-10,5	10,5 mm
5558	5127	5127-18,77	18,77 mm
	5127	5127-18,77	18,77 mm



E 74

PROFİLLER / PROFILES

COD Code	AGIRLIK (kg/m) Weight	Jxx cm4	Jyy cm4	Wxx cm3	Wyy cm3	L m
5128	3,652	---	----	---	---	6

KÖŞE TAKOZLARI / Corner Cleats

Nr	 L m	AKS. KODU Acs. Code	KESİM ÖLÇÜSÜ Cutting Size
5651	5128	5128-21,3	21,3 mm
	5128	5128-10,5	10,5 mm
5654	5128	5128-18,6	18,6 mm
	5128	5128-5,3	5,3 mm
5501	5128	5128-21,3	21,3 mm
	5128	5128-10,5	10,5 mm
5668	5128	5128-21,3	21,3 mm
	5128	5128-10,5	10,5 mm
5669	5128	5128-21,3	21,3 mm
	5128	5128-10,5	10,5 mm
5660	5128	5128-21,3	21,3 mm
	5128	5128-10,5	10,5 mm
5504	5128	5128-18,6	18,6 mm
	5128	5128-5,3	5,3 mm
5508	5128	5128-21,3	21,3 mm
	5128	5128-10,5	10,5 mm
5673	5128	5128-21,3	21,3 mm
	5128	5128-10,5	10,5 mm
5663	5128	5128-21,3	21,3 mm
	5128	5128-10,5	10,5 mm
5670	5128	5128-18,3	18,3 mm
	5128	5128-5,4	5,3 mm
5511	5128	5128-21,3	21,3 mm
	5128	5128-10,5	10,5 mm
5664	5128	5128-21,3	21,3 mm
	5128	5128-10,5	10,5 mm
5556	5128	5128-18,6	18,6 mm
	5128	5128-5,3	5,3 mm
5512	5128	5128-21,3	21,3 mm
	5128	5128-10,5	10,5 mm
5674	5128	5128-21,3	21,3 mm
	5128	5128-10,5	10,5 mm
5675	5128	5128-21,3	21,3 mm
	5128	5128-10,5	10,5 mm
5676	5128	5128-21,3	21,3 mm
	5128	5128-10,5	10,5 mm

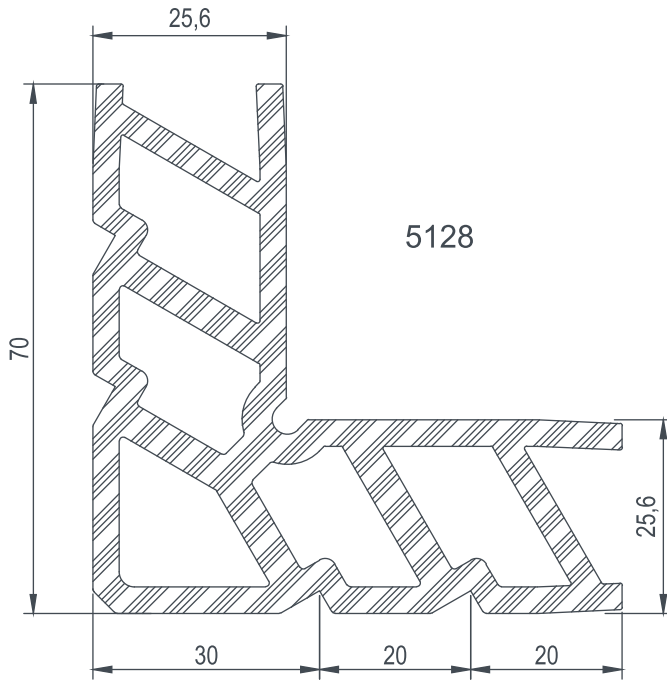



E 74

PROFİLLER / PROFILES

COD Code	AGIRLIK (kg/m) Weight	Jxx cm4	Jyy cm4	Wxx cm3	Wyy cm3	L m
5129	4,618	---	---	---	---	6

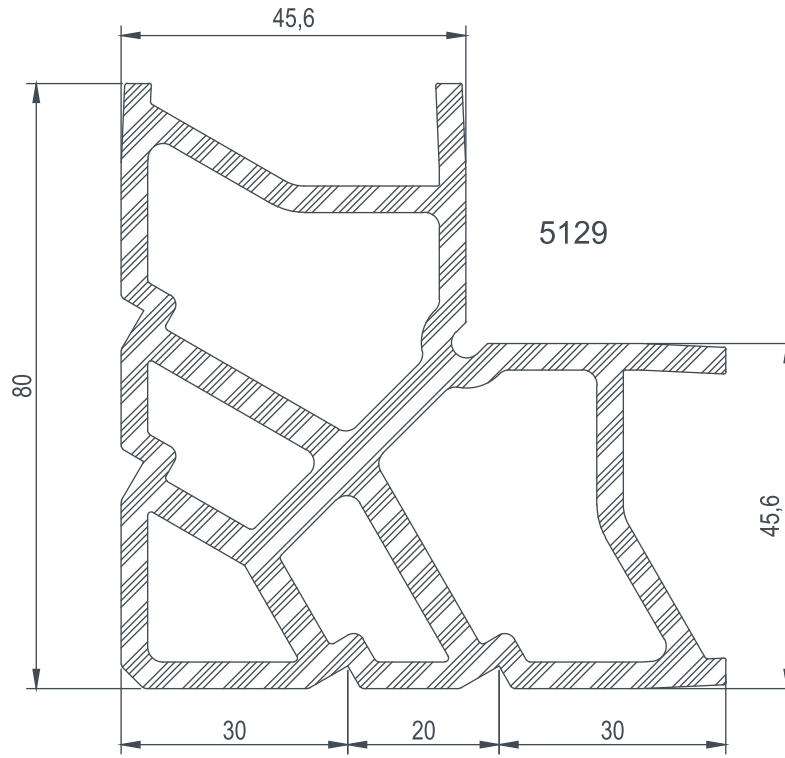

KÖŞE TAKOZLARI / Corner Cleats

Nr	 L m	AKS. KODU Acs. Code	KESİM ÖLÇÜSÜ Cutting Size
5502	5129	5129-21,3	21,3 mm
	5129	5129-10,5	10,5 mm
5506	5129	5129-26,7	26,7 mm
	5129	5129-5,3	5,3 mm
5509	5129	5129-21,3	21,3 mm
	5129	5129-10,5	10,5 mm
5652	5129	5129-21,3	21,3 mm
	5129	5129-10,5	10,5 mm
5658	5129	5129-26,7	26,7 mm
	5129	5129-5,3	5,3 mm
5661	5129	5129-21,3	21,3 mm
	5129	5129-10,5	10,5 mm
5557	5129	5129-18,3	18,3 mm
	5129	5129-5,4	5,4 mm
5580	5129	5129-21,3	21,3 mm
	5129	5129-10,5	10,5 mm



E 74

PROFİLLER / PROFILES

COD Code	AGIRLIK (kg/m) Weight	Jxx cm4	Jyy cm4	Wxx cm3	Wyy cm3	L m
4542	5,381	---	---	---	---	6

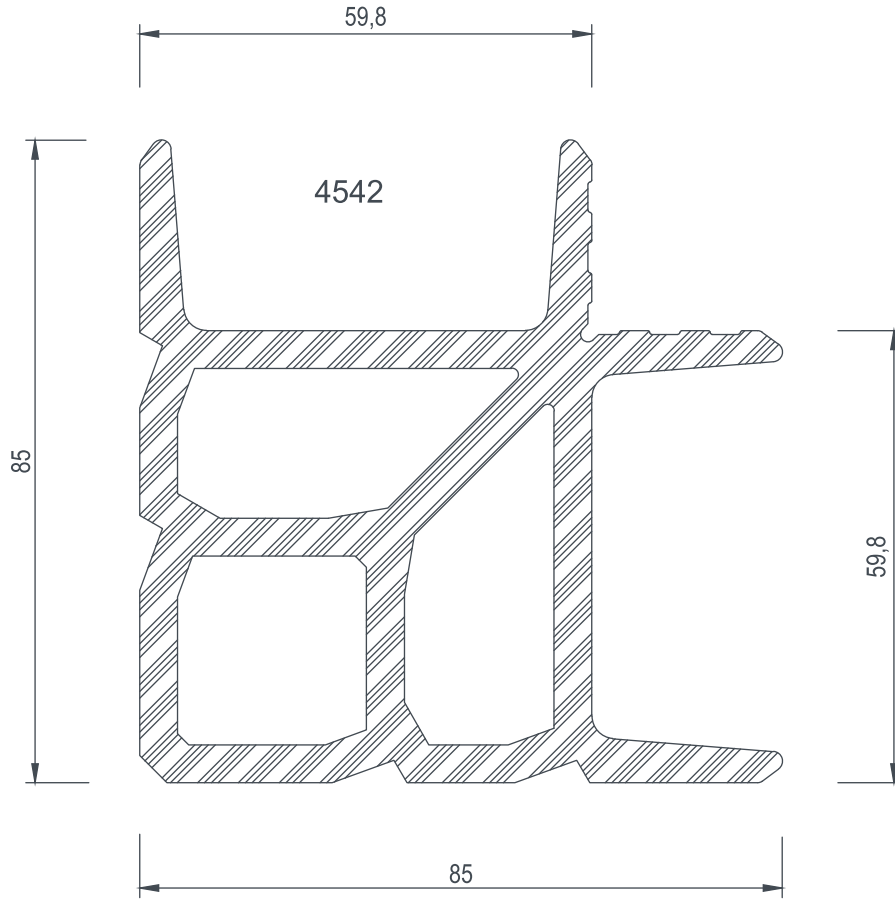

KÖŞE TAKOZLARI / Corner Cleats

Nr	AKS. KODU Acs. Code	KESİM ÖLÇÜSÜ Cutting Size
5657	4542-18,6	18,6 mm
	4542-5,3	5,3 mm
5568	4542-18,6	18,6 mm
	4542-5,3	5,3 mm
5672	4542-18,6	18,6 mm
	4542-5,3	5,3 mm



E 74

PROFİLLER / PROFILES

COD Code	AGIRLIK (kg/m) Weight	Jxx cm4	Jyy cm4	Wxx cm3	Wyy cm3	L m
5569	0,555	---	----	---	---	6
5570	0,393	---	----	---	---	6
5571	0,772	---	----	---	---	6

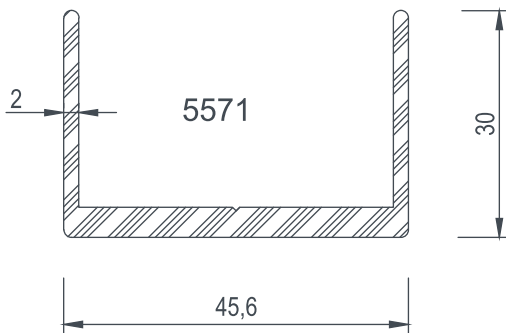
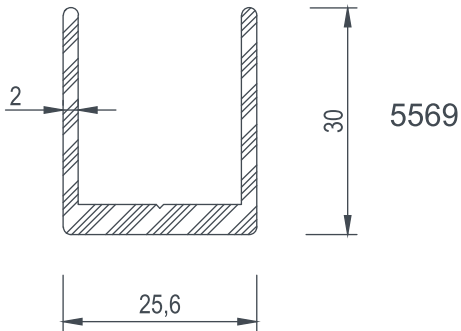
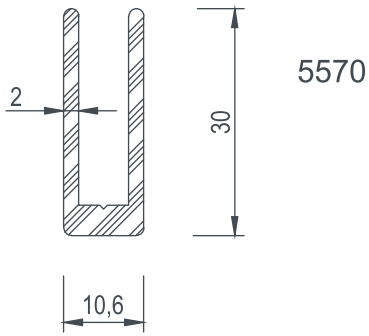

ORTA KAYIT BAĞLANTI / Mullion Connection Piece

Nr	L m	AKS. KODU Acs. Code	KESİM ÖLÇÜSÜ Cutting Size
5507	5570	5570-21,3	21,3 mm
5508	5569	5569-21,3	21,3 mm
5509	5571	5571-45,6	45,6 mm
5510	----	----	---
5511	5569	5569-21,3	21,3 mm
5512	5569	5569-21,3	21,3 mm
5513	5569	5569-21,3	21,3 mm
5659	5570	5570-21,3	21,3 mm
5660	5569	5569-21,3	21,3 mm
5661	5571	5571-45,6	45,6 mm
5662	----	----	---
5663	5569	5569-21,3	21,3 mm
5664	5569	5569-21,3	21,3 mm
5665	5569	5569-21,3	21,3 mm
5513	5569	5569-21,3	21,3 mm
5673	5569	5569-21,3	21,3 mm

clarks

E 74

DETAYLAR
DETAILS







E 74

DEAYLAR / DETAILS

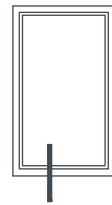
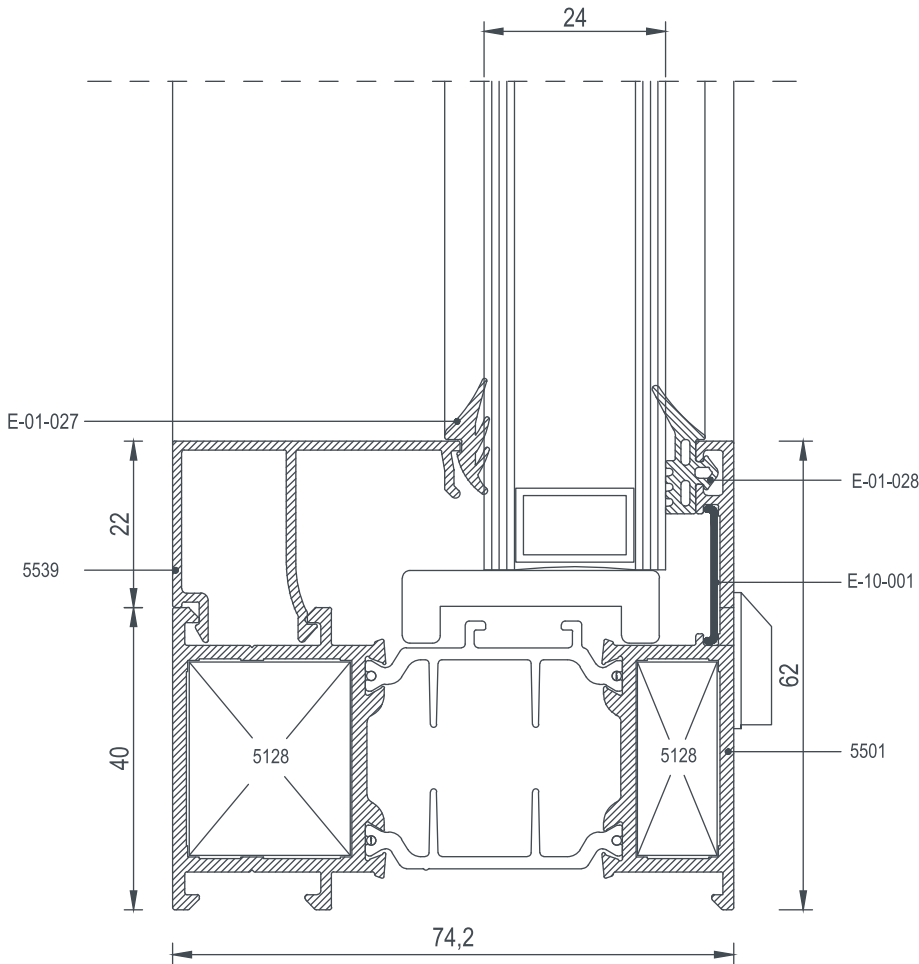
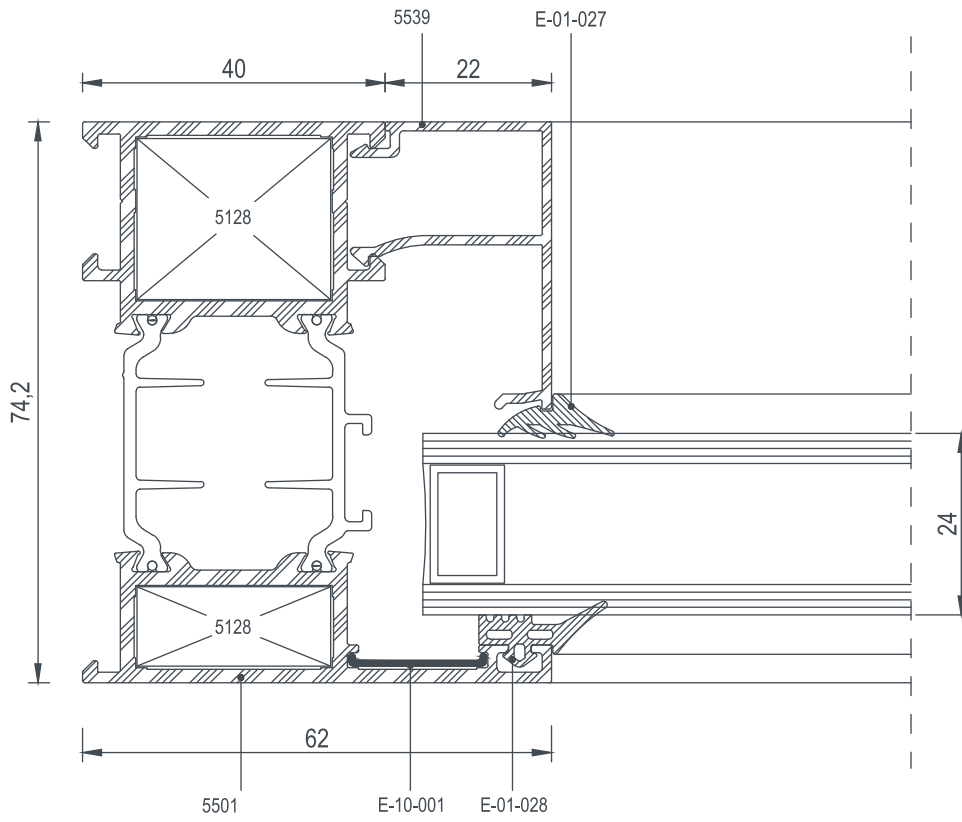

205





E 74

DETYLAR / DETAILS

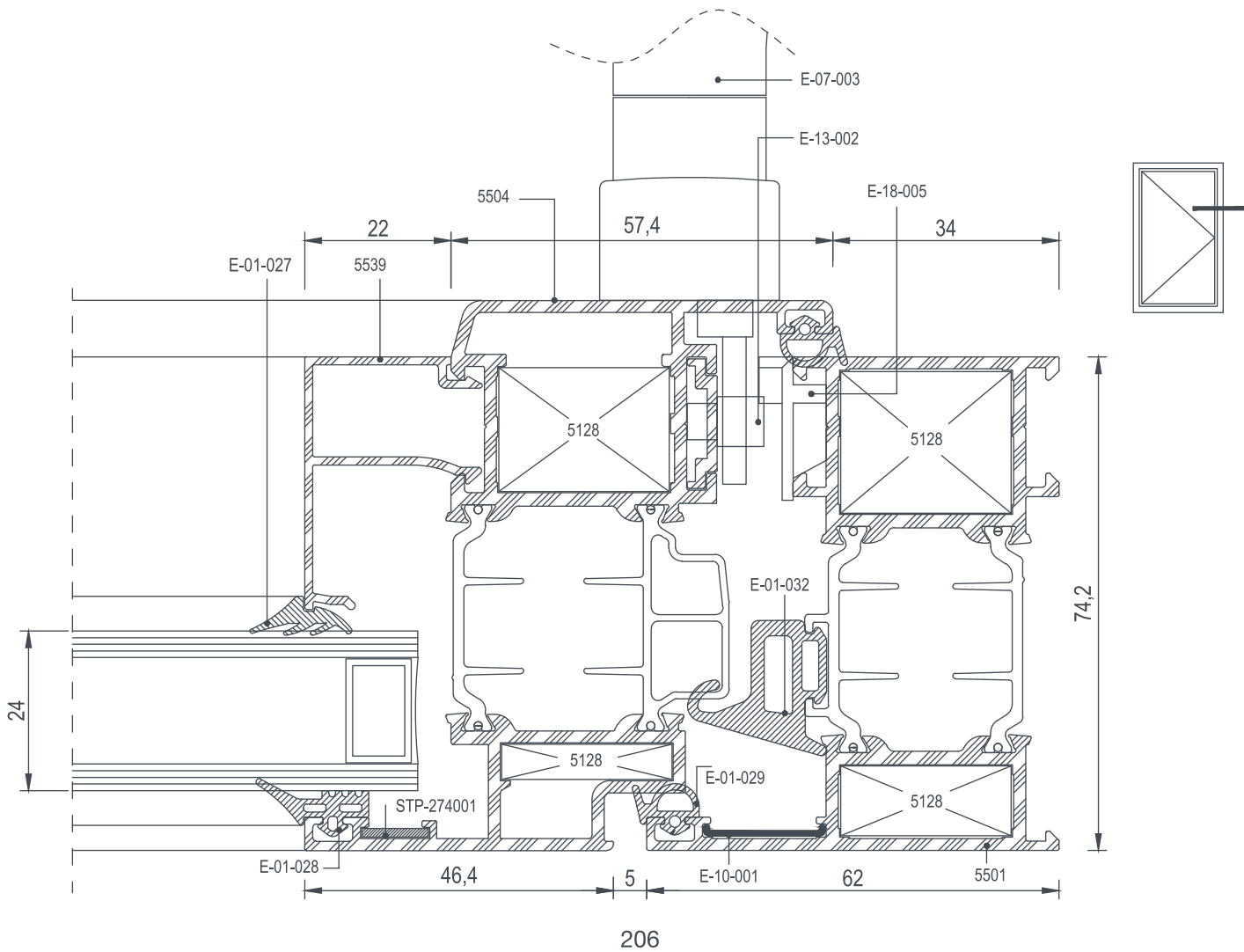
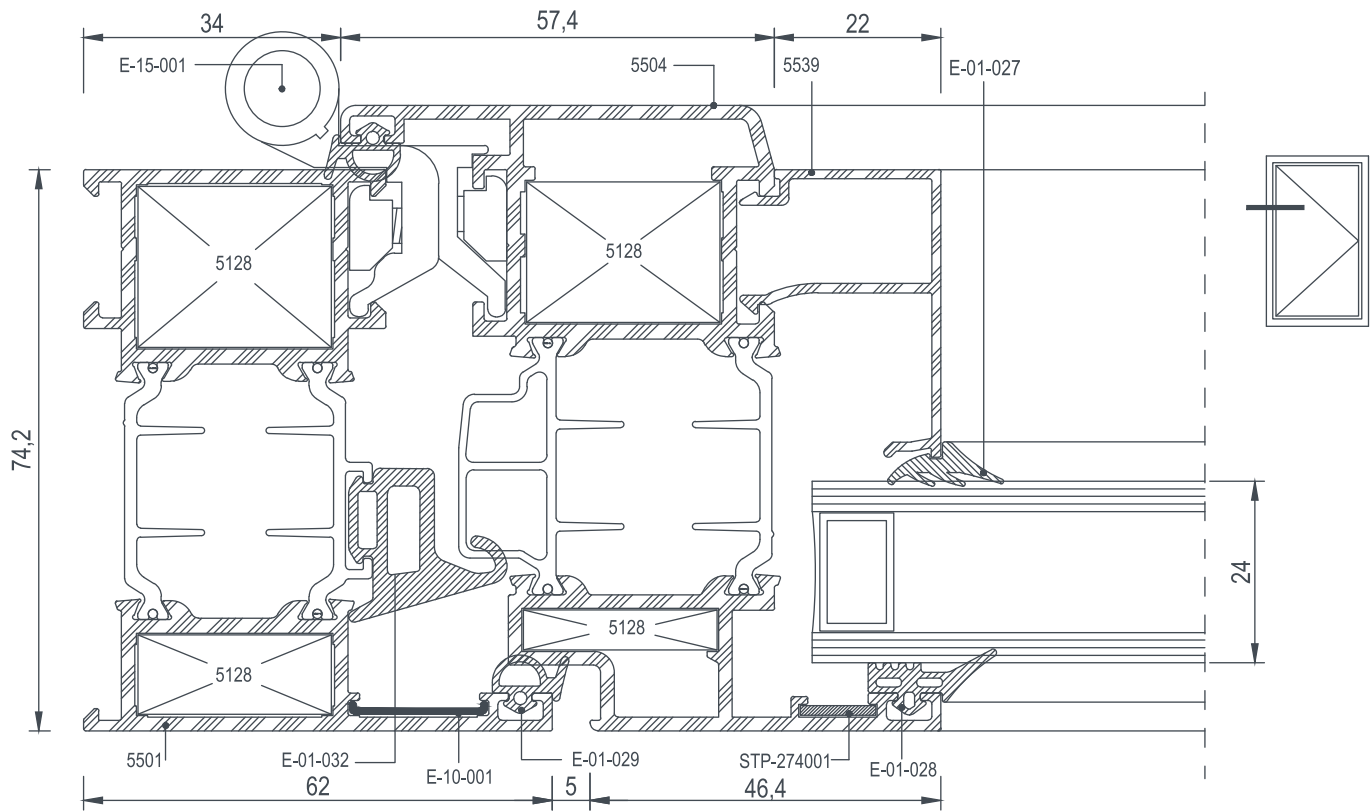



E 74

DEAYLAR / DETAILS

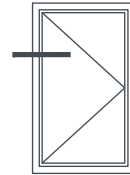
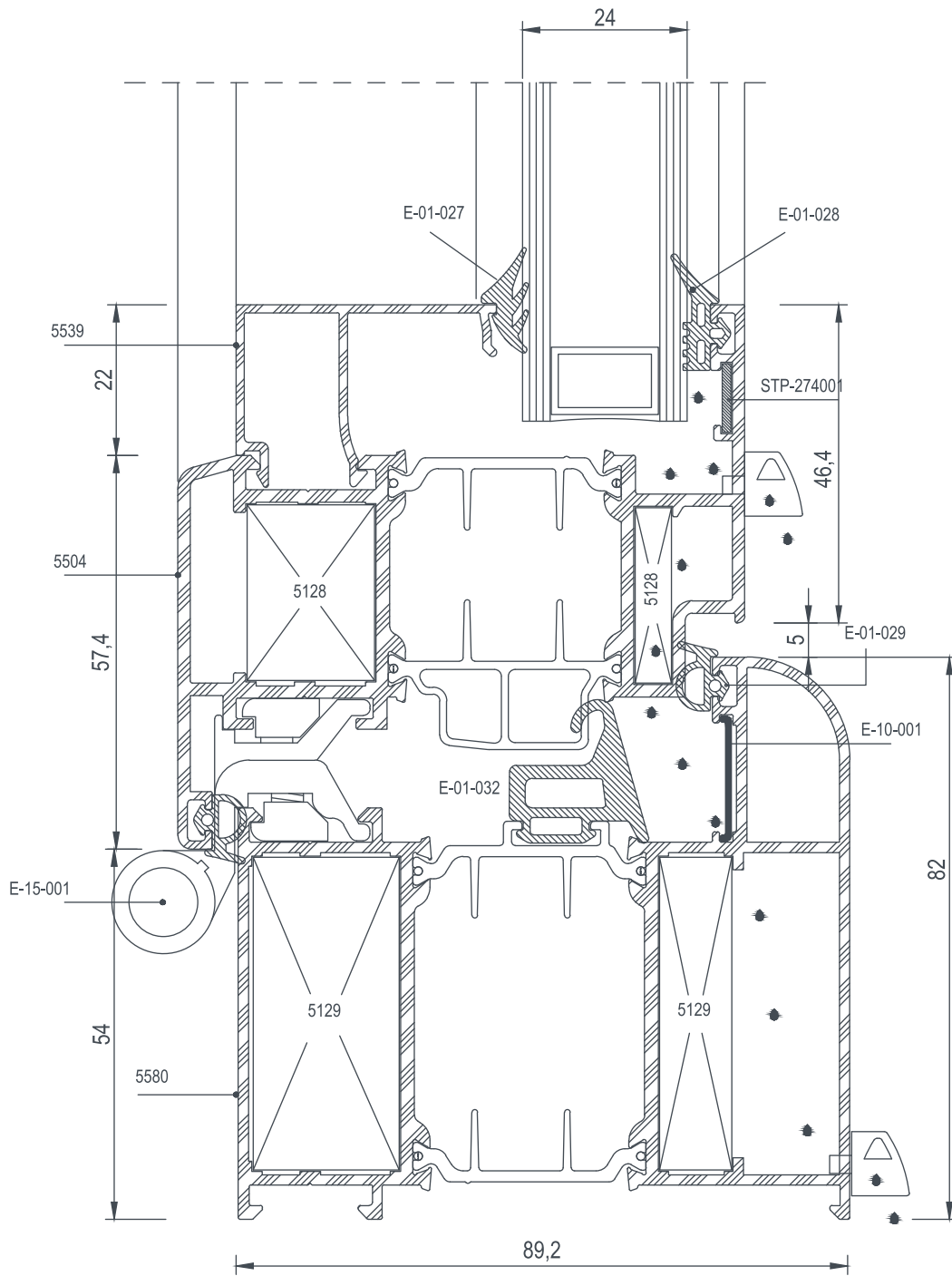



E 74

DEAYLAR / DETAILS

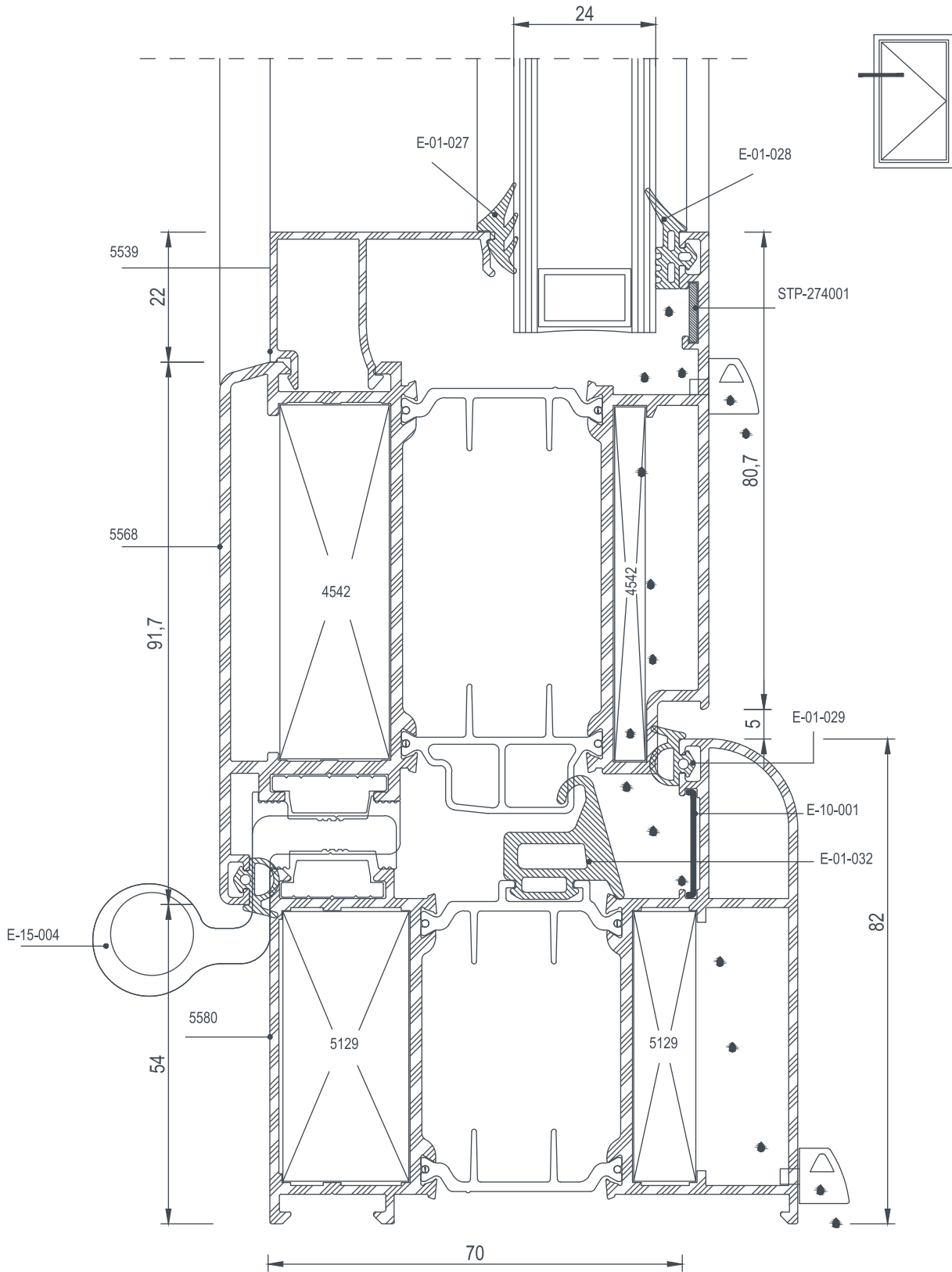



E 74

DETAYLAR / DETAILS

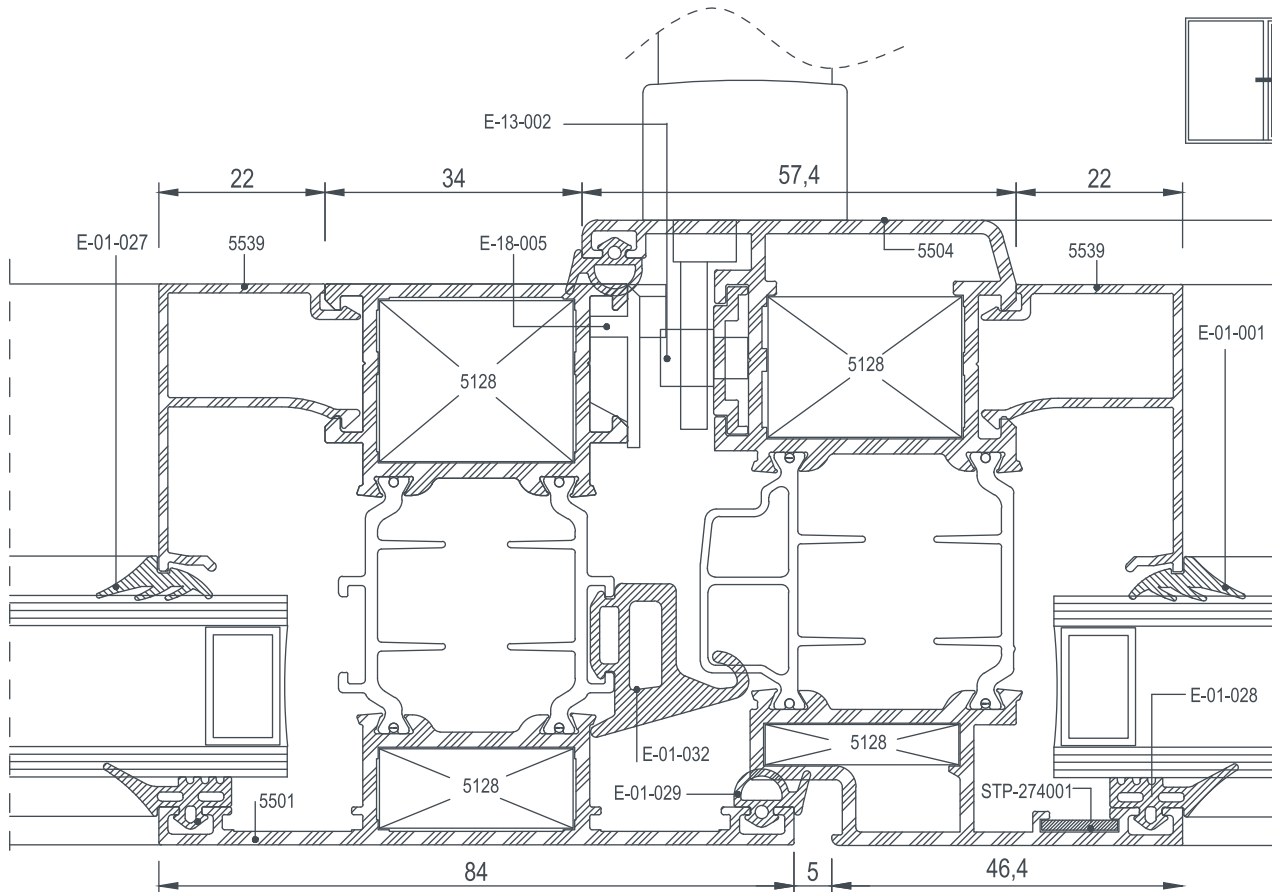
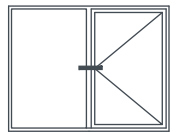
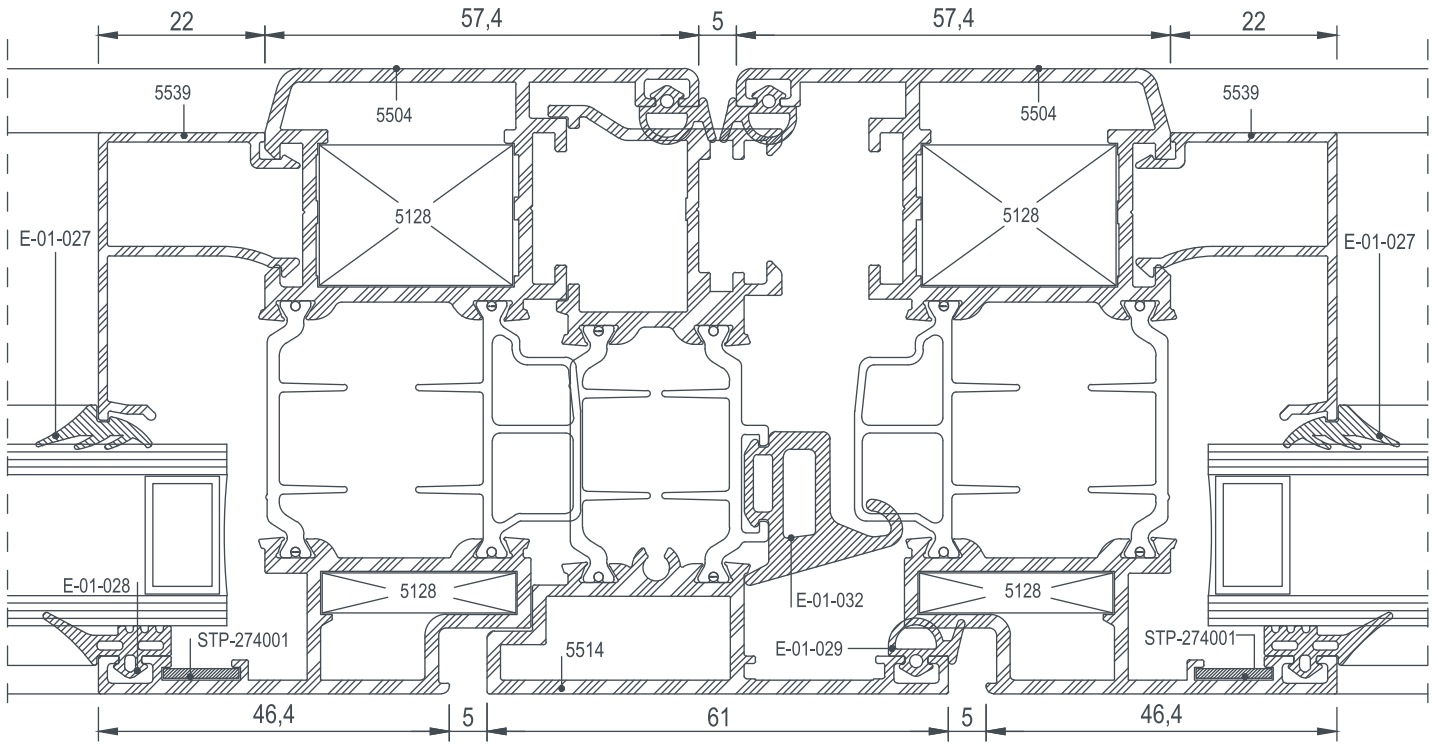
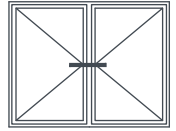

209





E 74

DETAYLAR / DETAILS

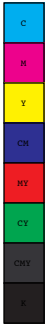
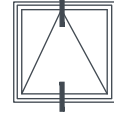
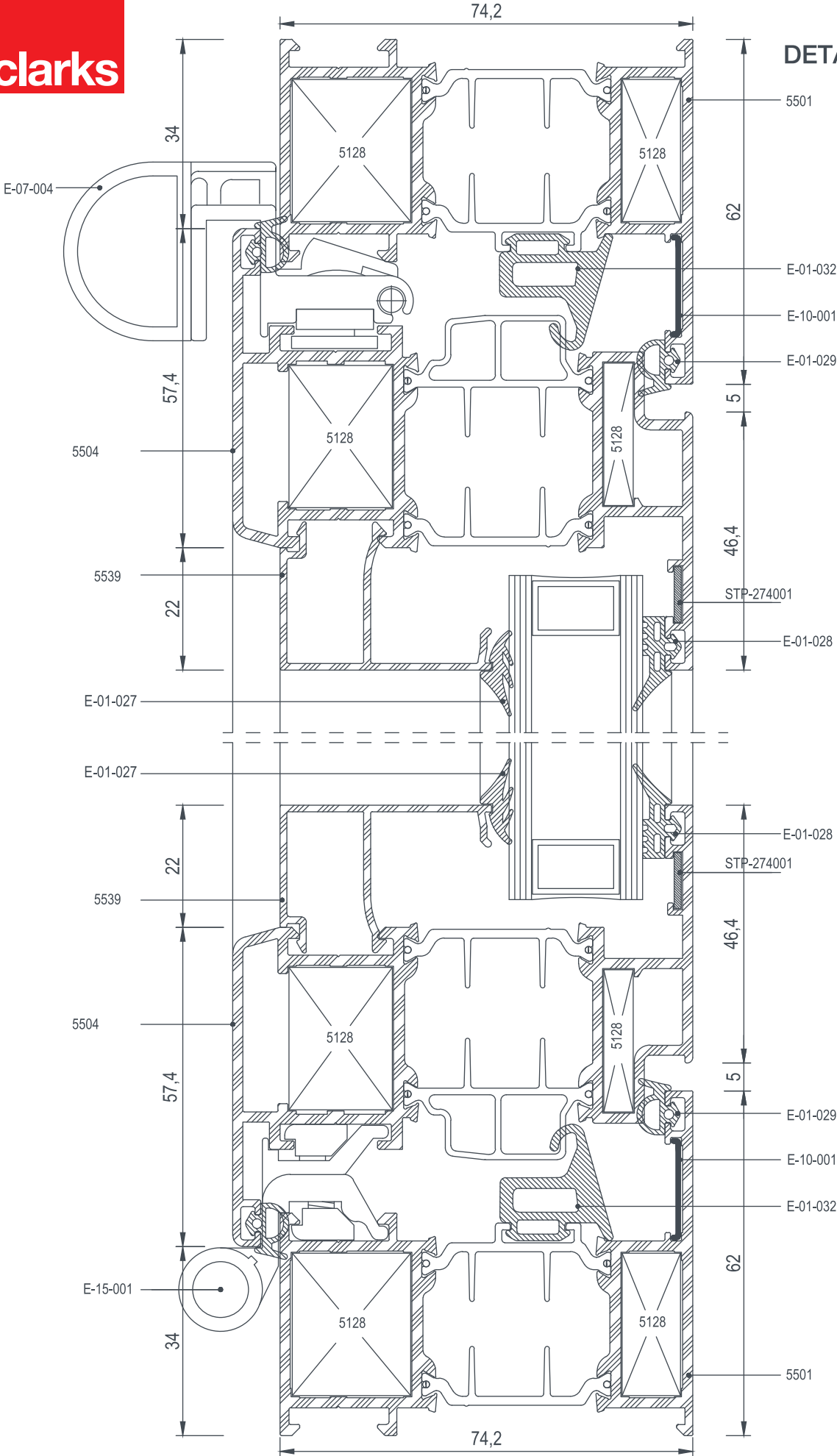



E 74

DETAYLAR / DETAILS

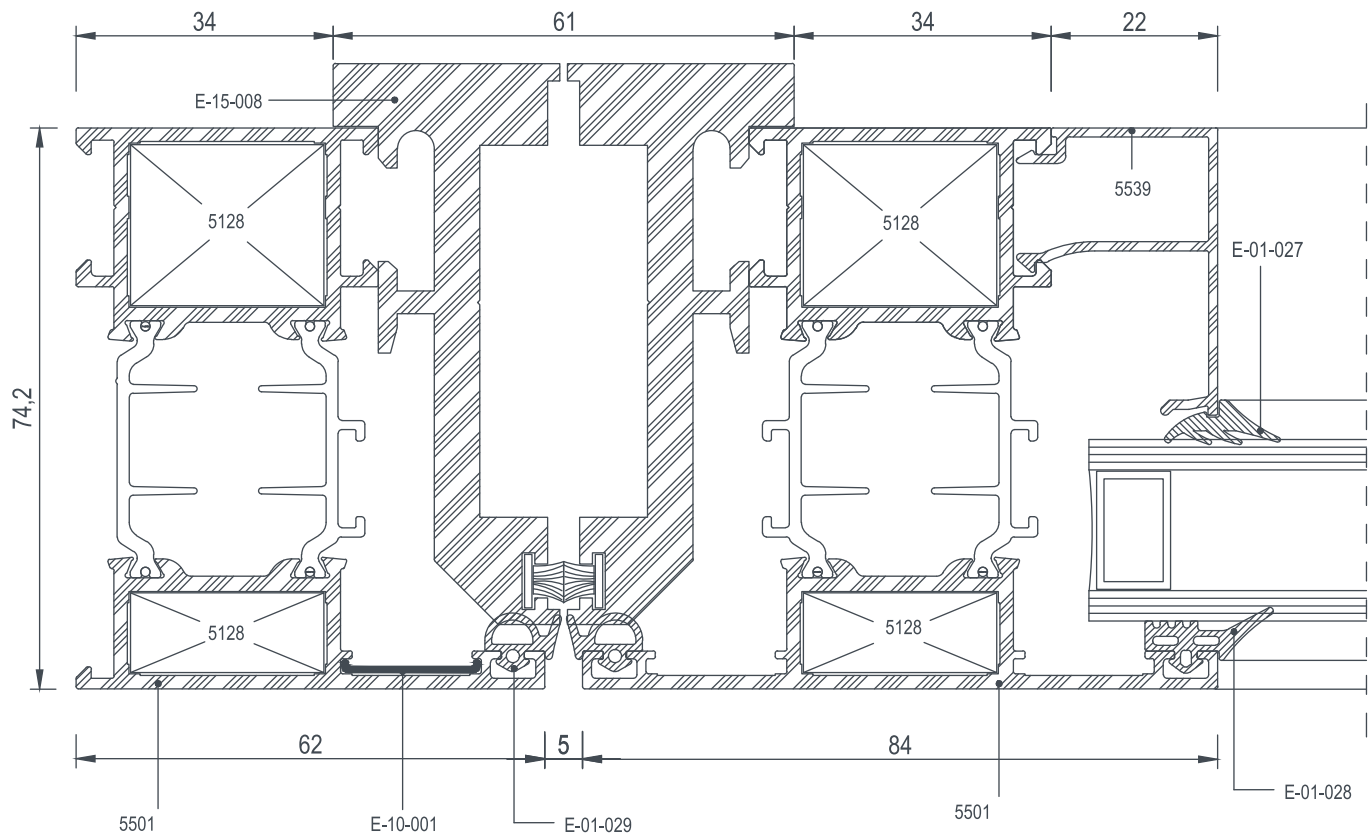
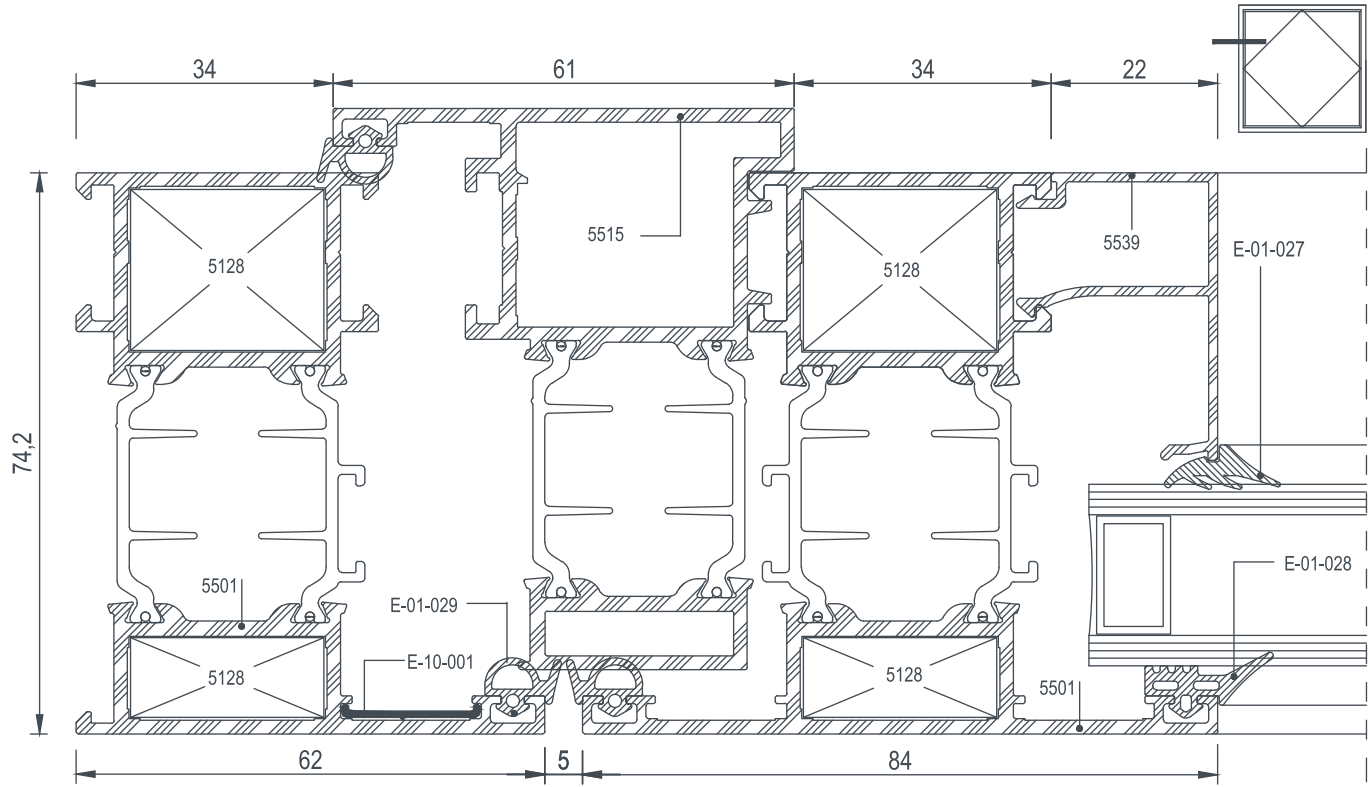



E 74

DEYAYLAR / DETAILS

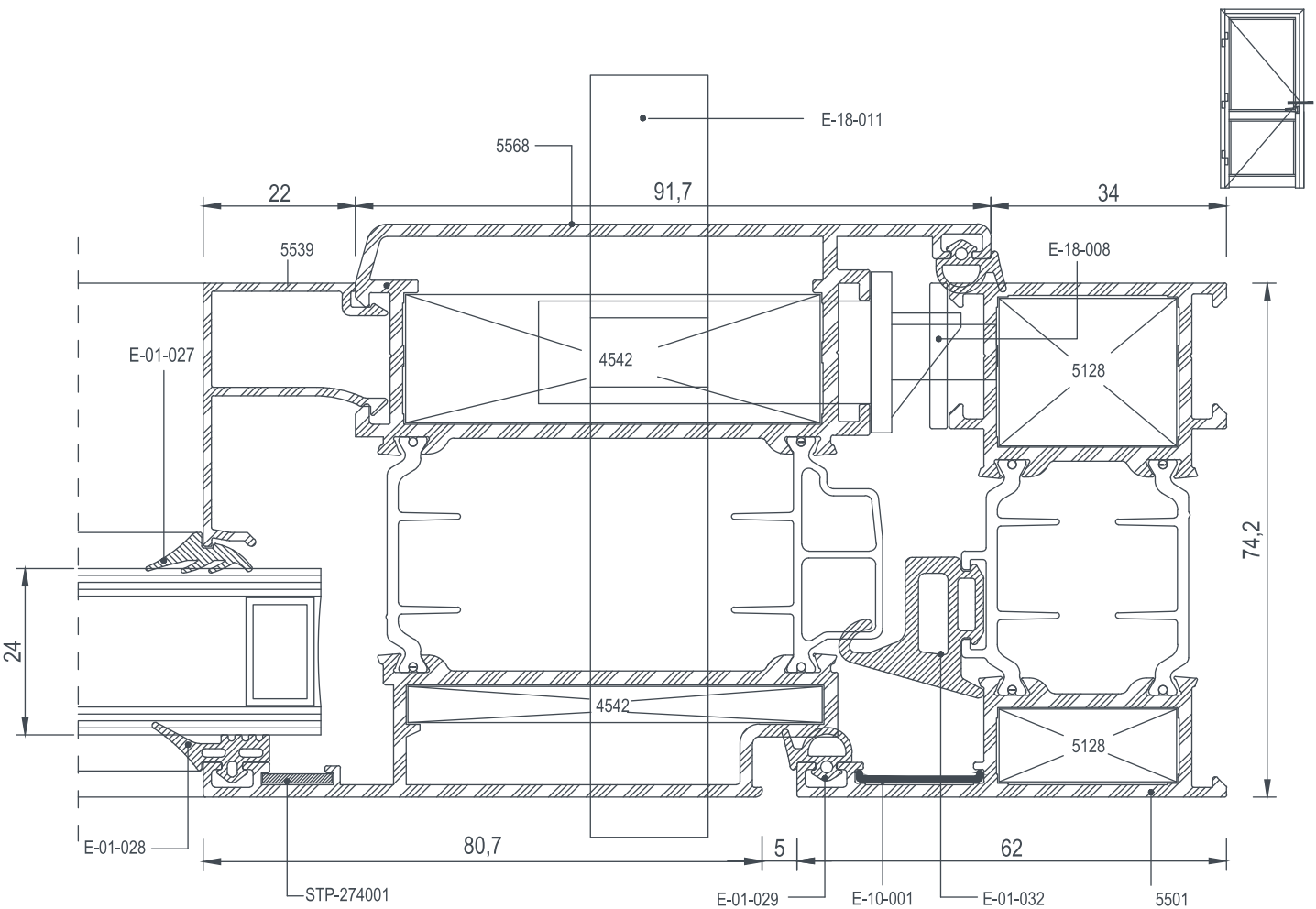
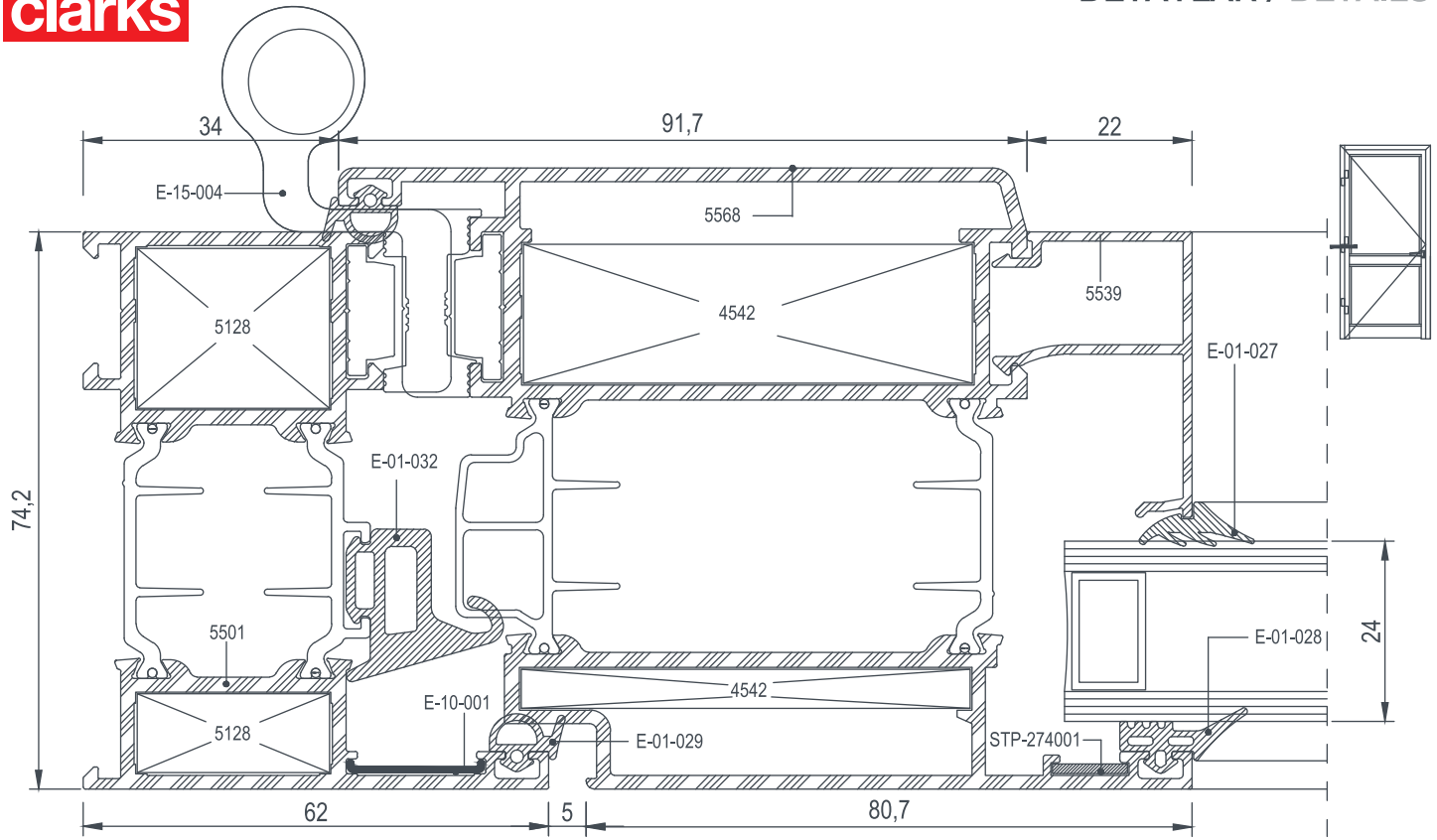



E 74

DETAYLAR / DETAILS

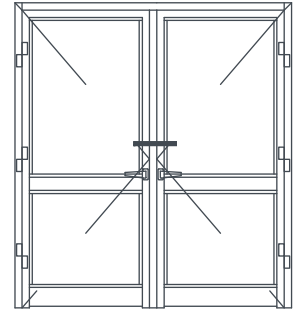
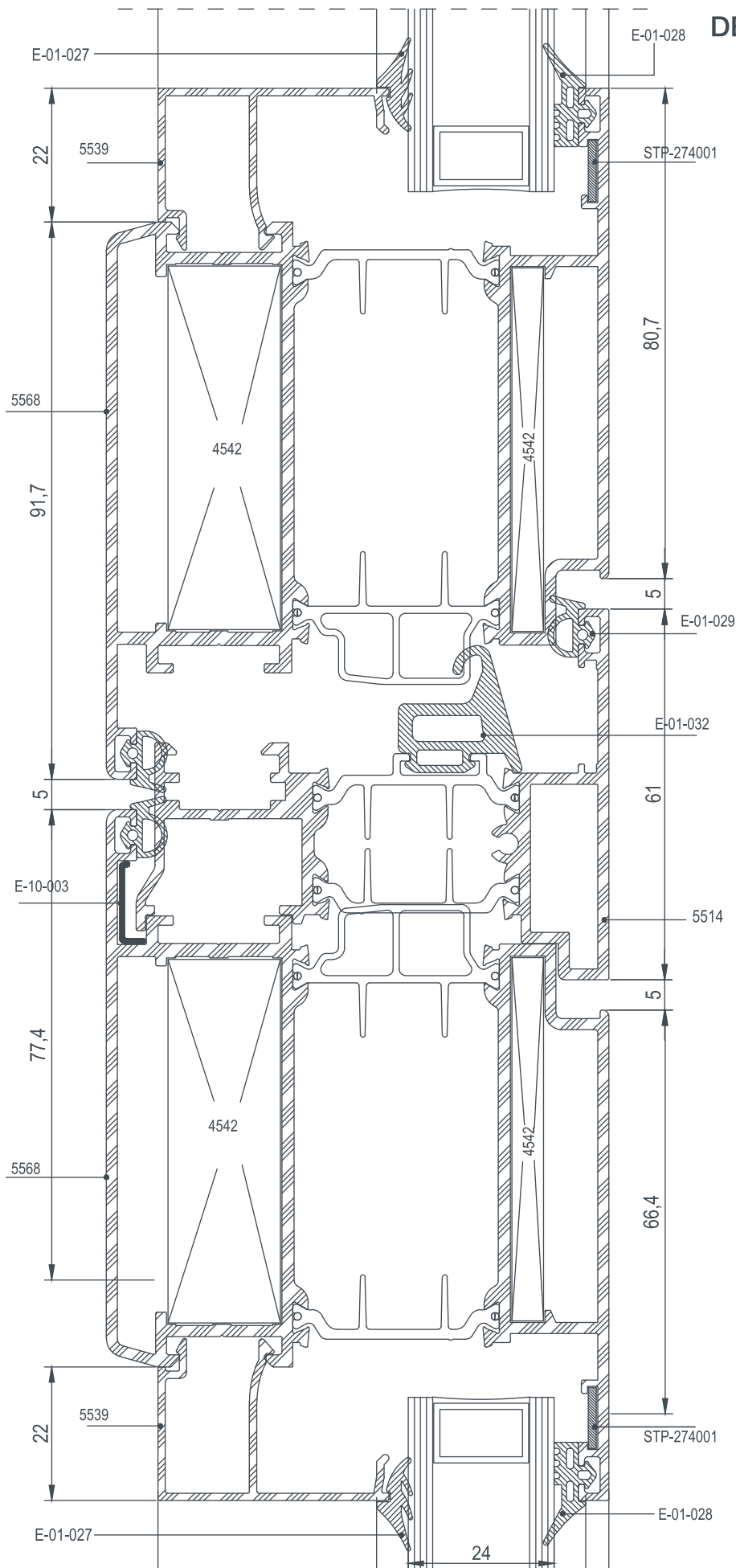



E 74

DETAYLAR / DETAILS

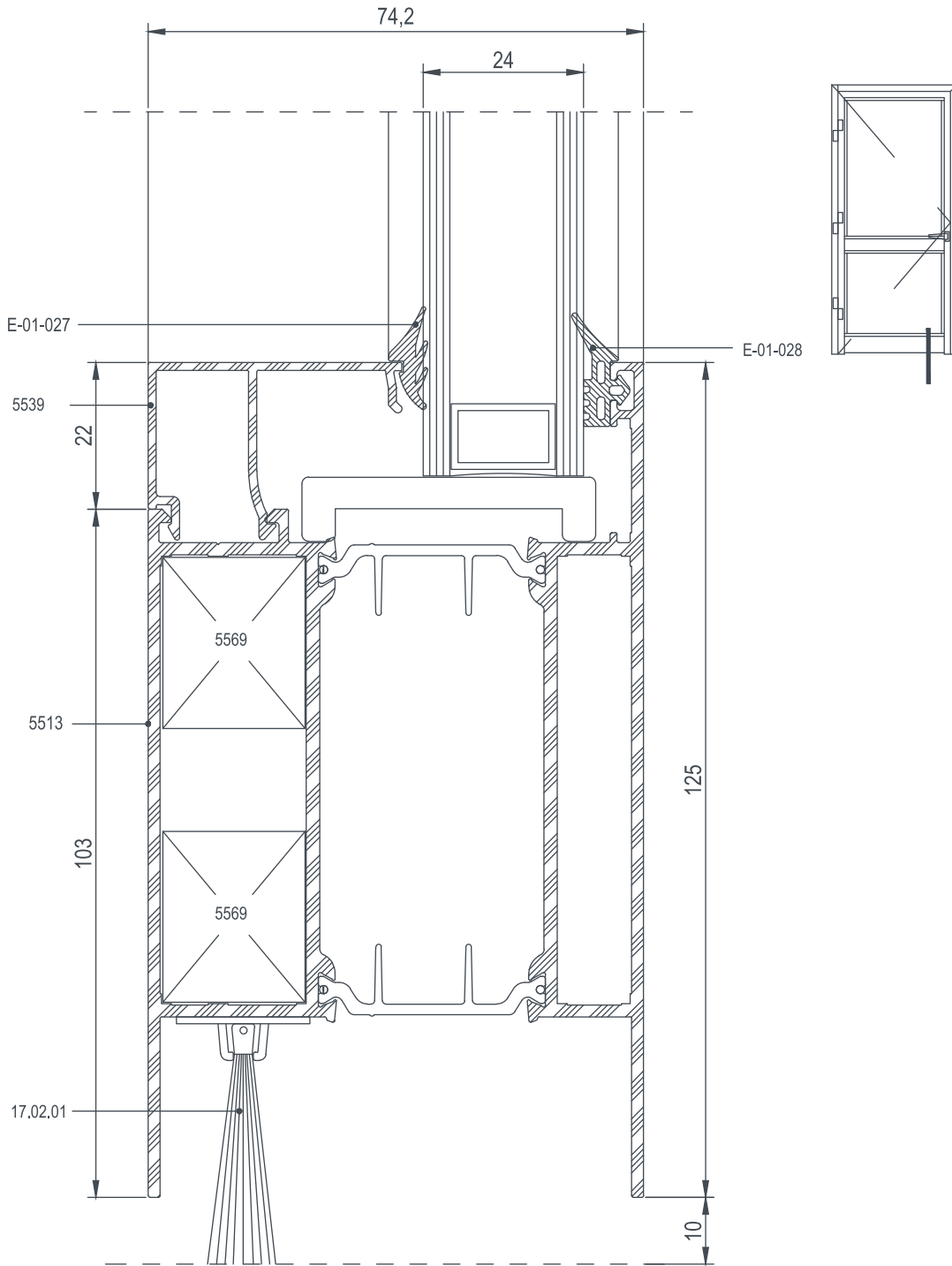



E 74

DEYAYLAR / DETAILS

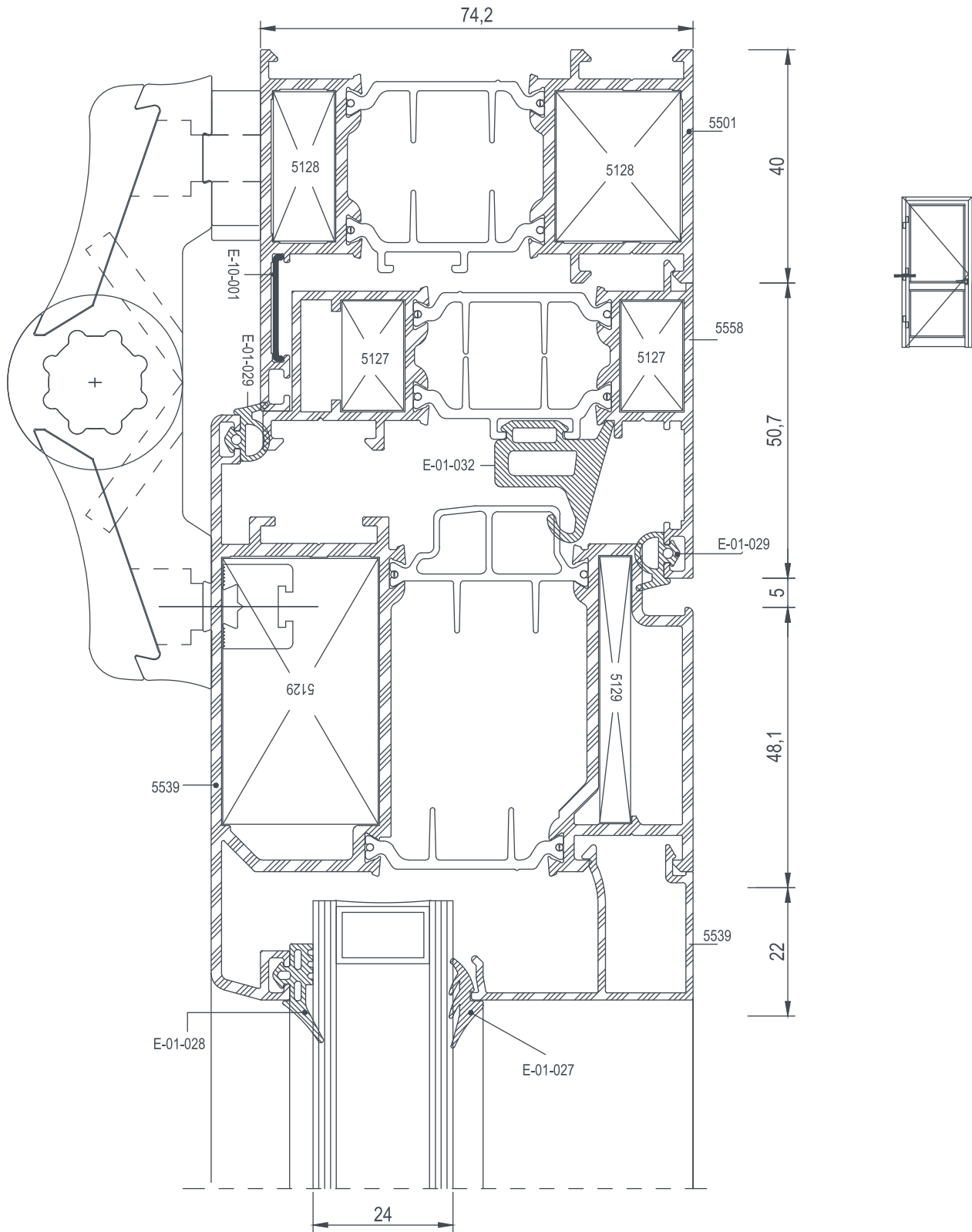



E 74

DEAYLAR / DETAILS

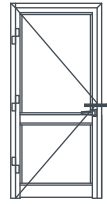
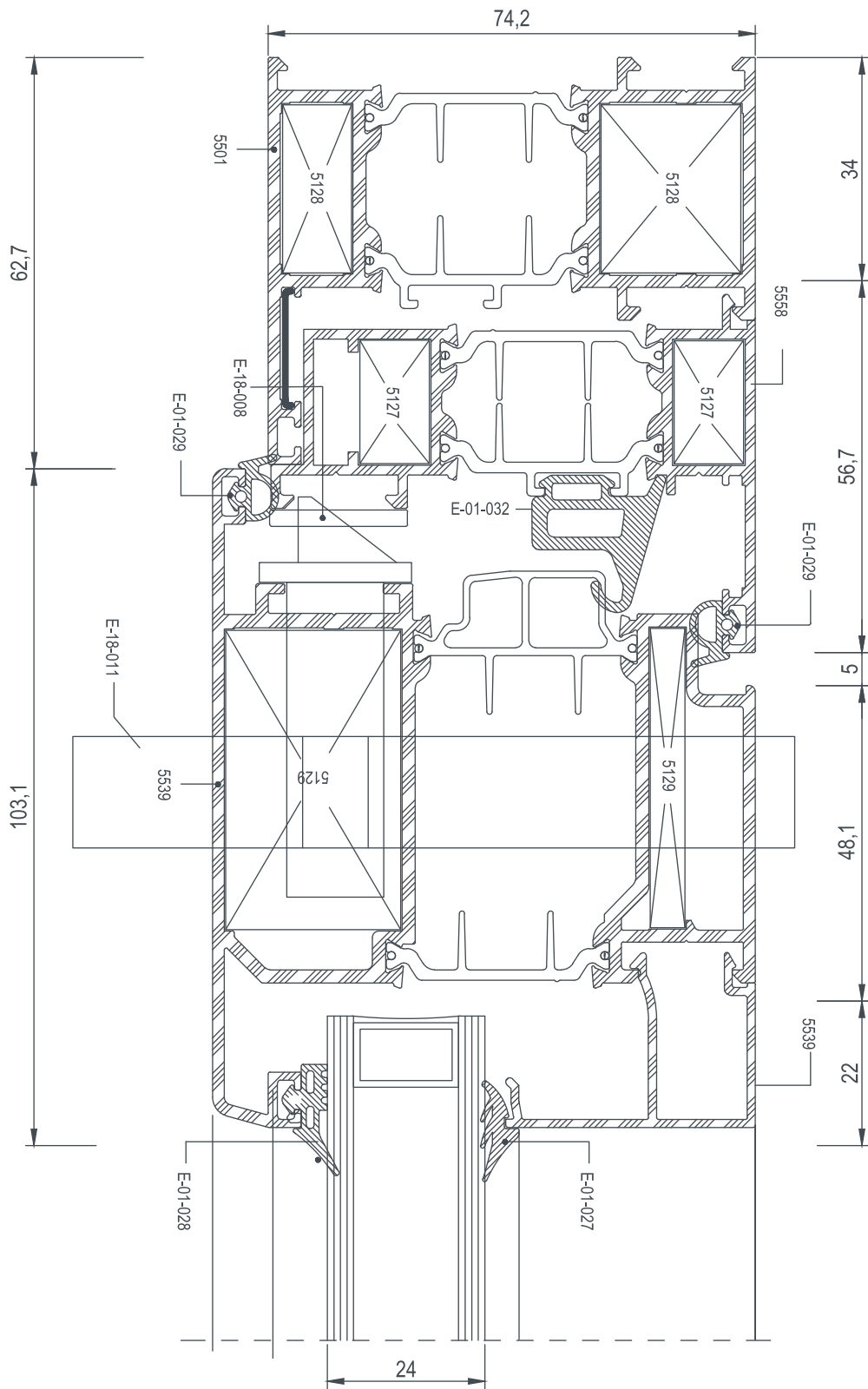



E 74

DEAYLAR / DETAILS

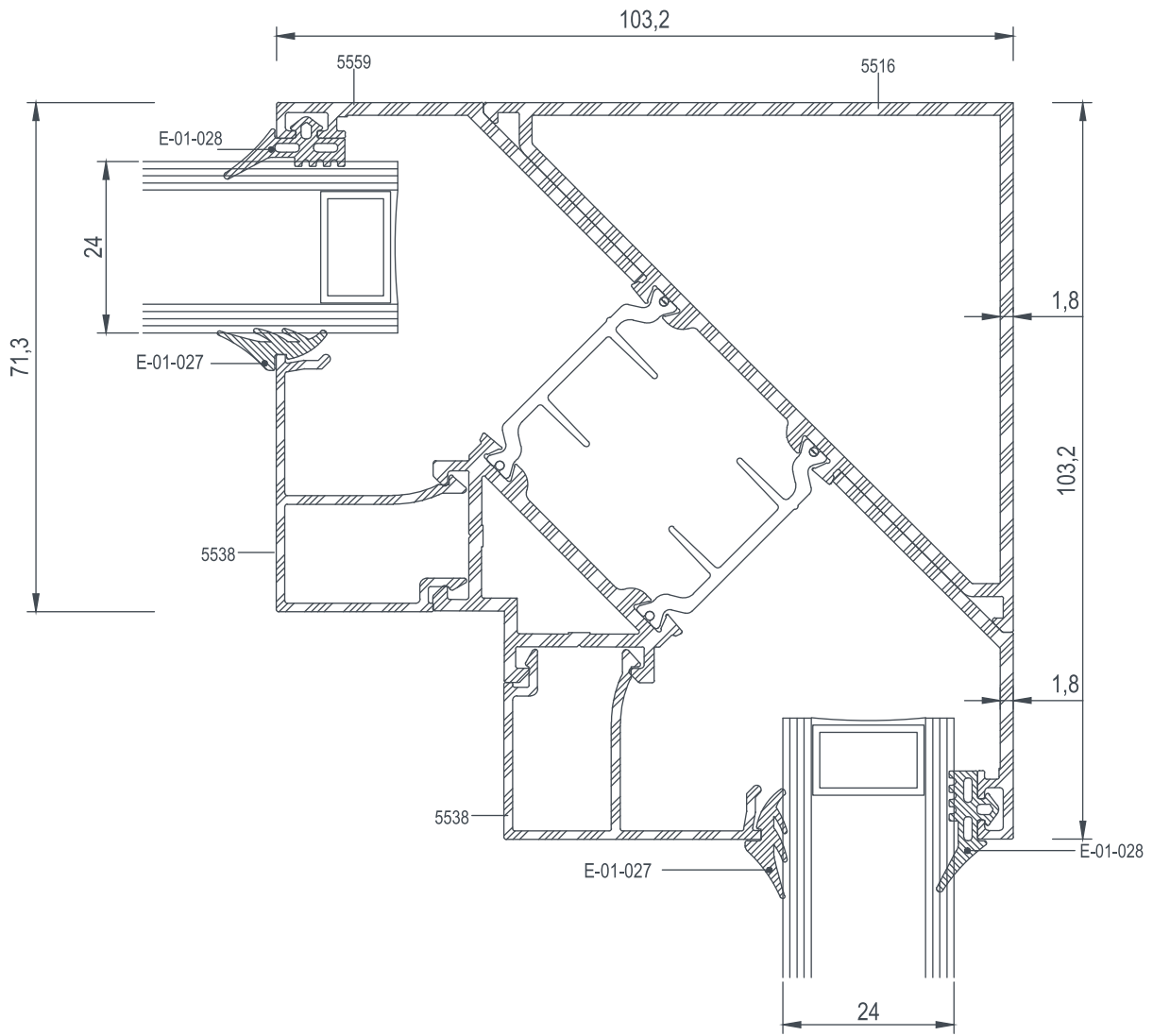
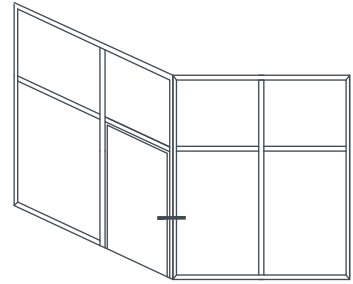



E 74

DEAYLAR / DETAILS

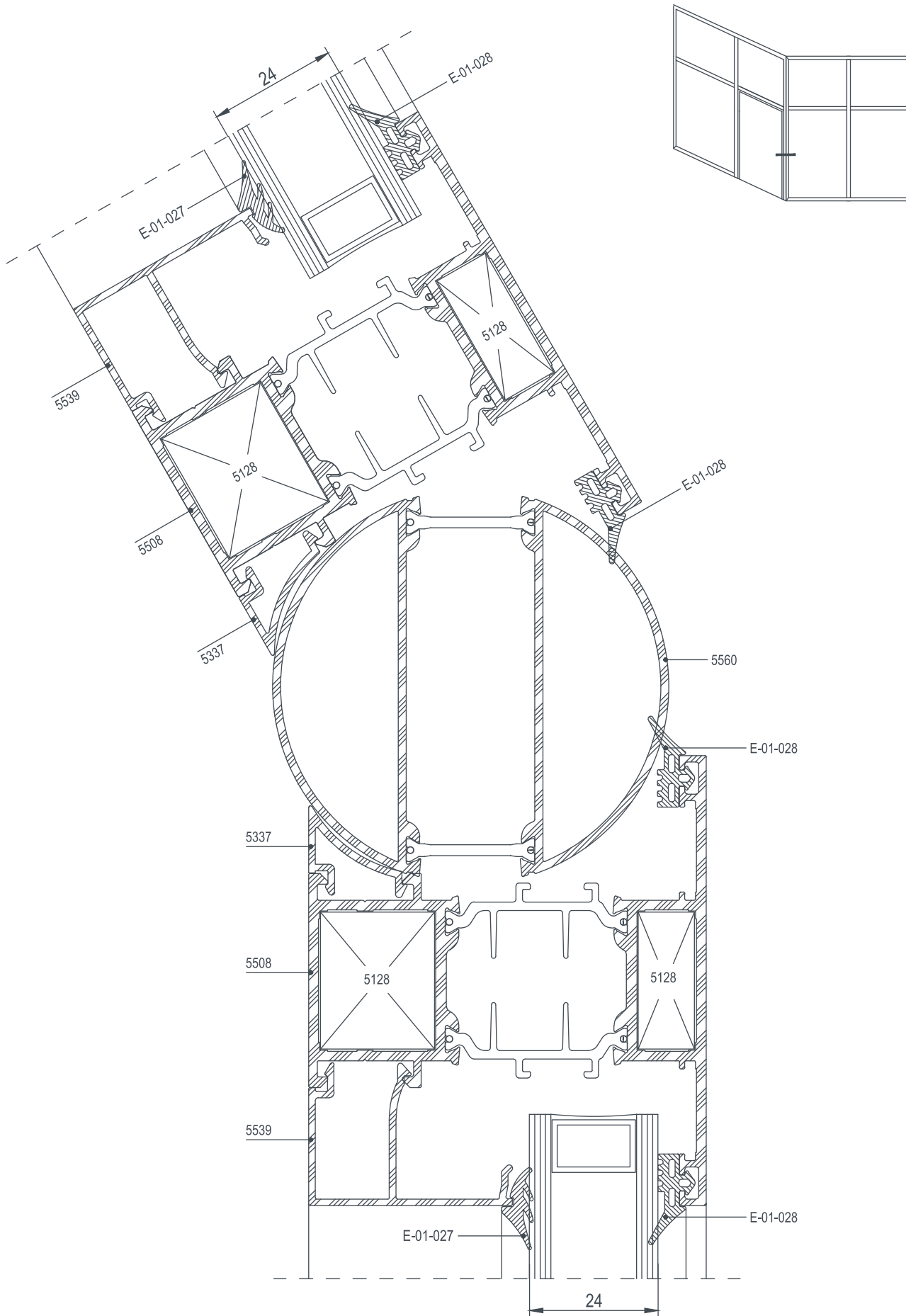



E 74

DEAYLAR / DETAILS

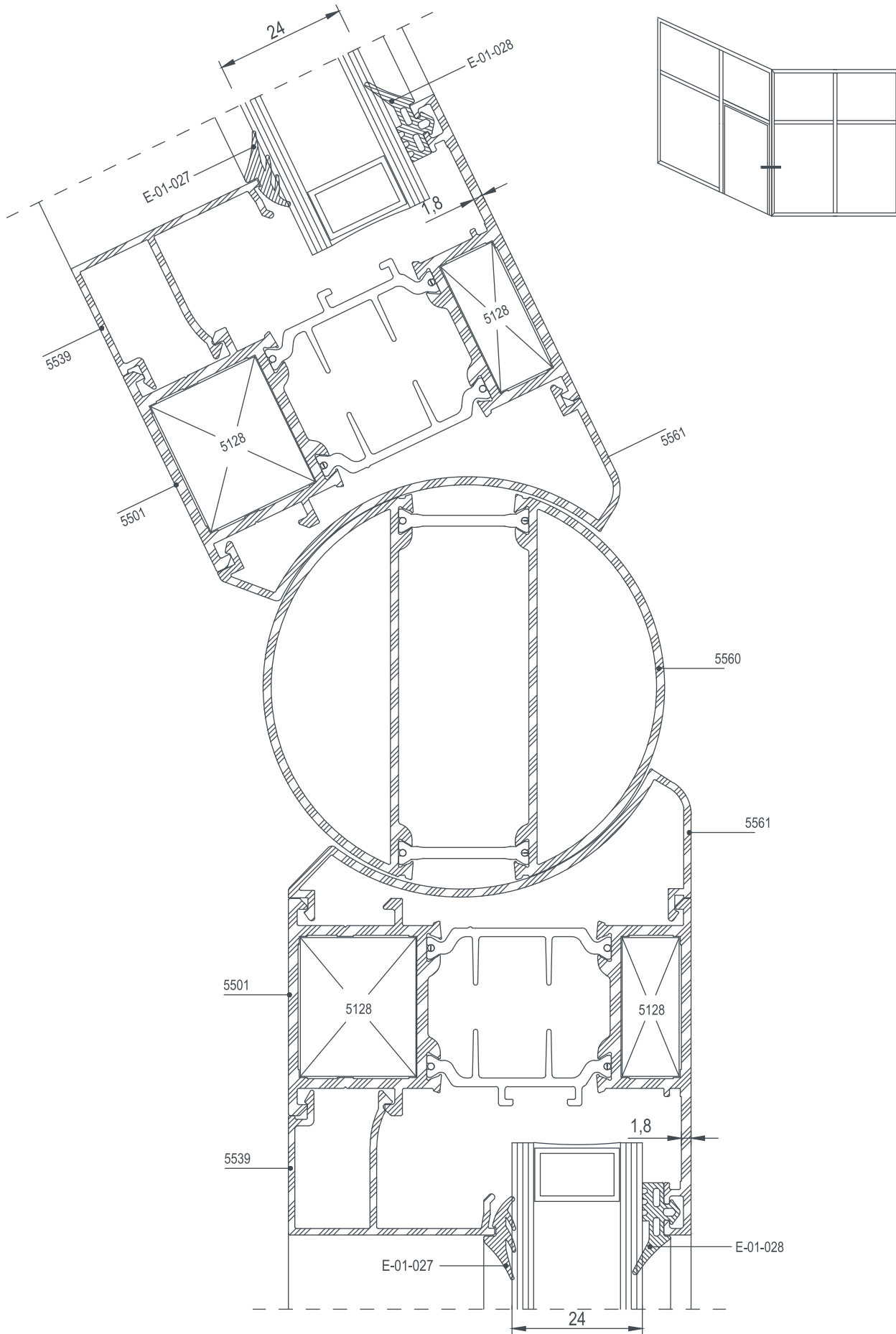



clarks

E 74

DETAYLAR

DETAILS

E 74 - GİZLİ KANAT PROFİLİ DETAYLARI
E 74 - SECRET SASH PROFILE DETAILS





E 74

DETAYLAR / DETAILS

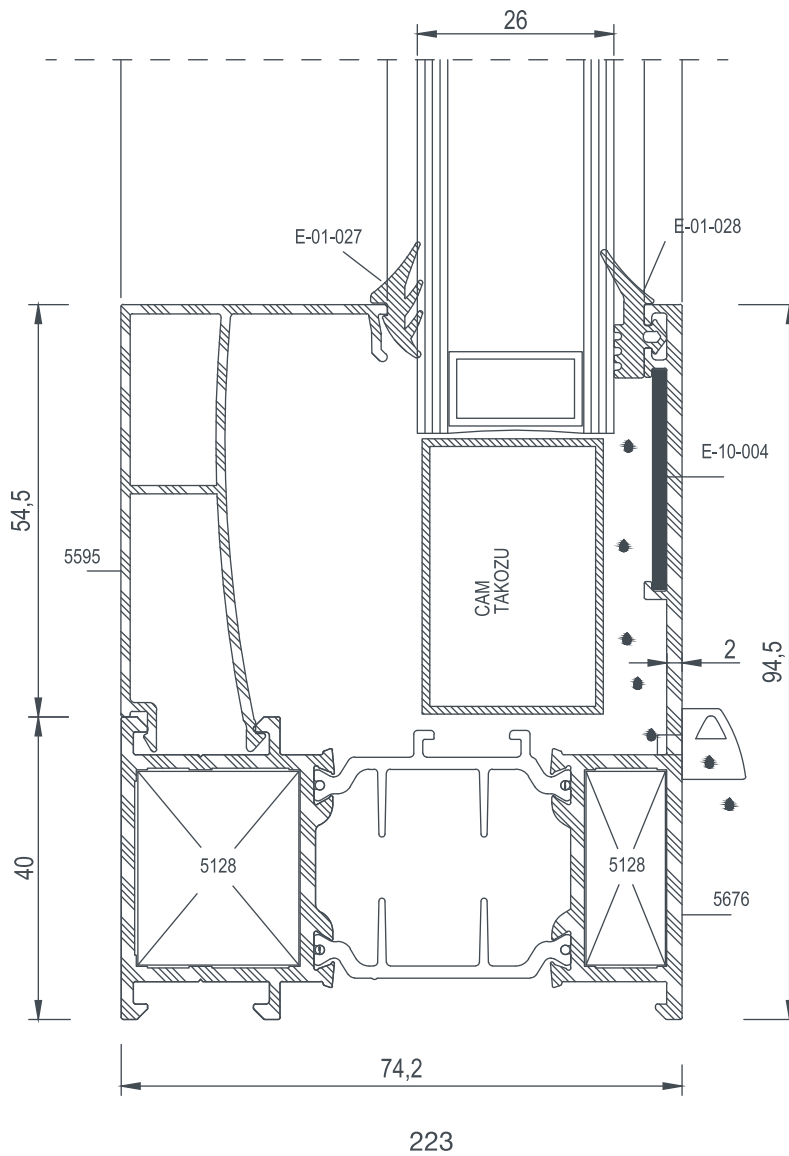
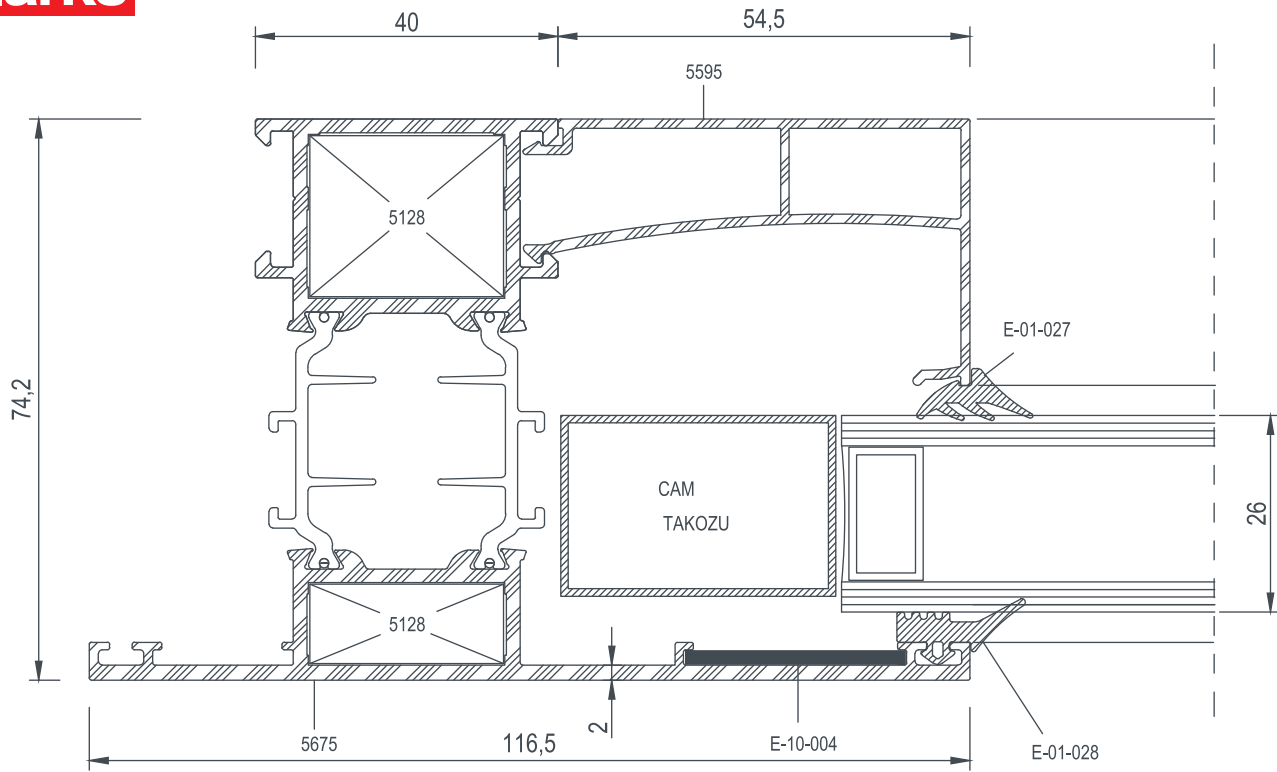



E 74

DEAYLAR / DETAILS

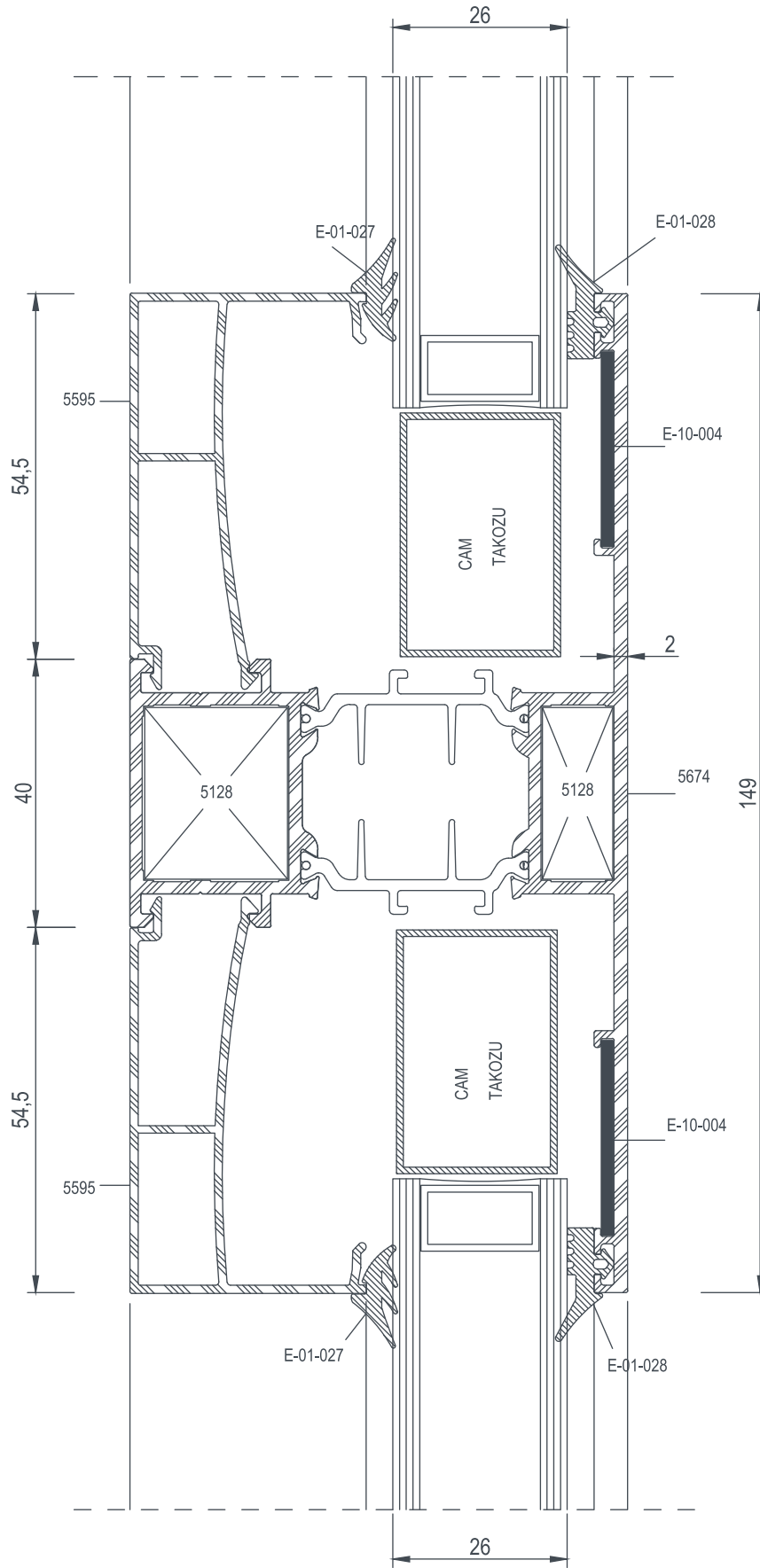



E 74

DETAYLAR / DETAILS

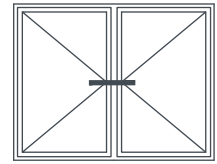
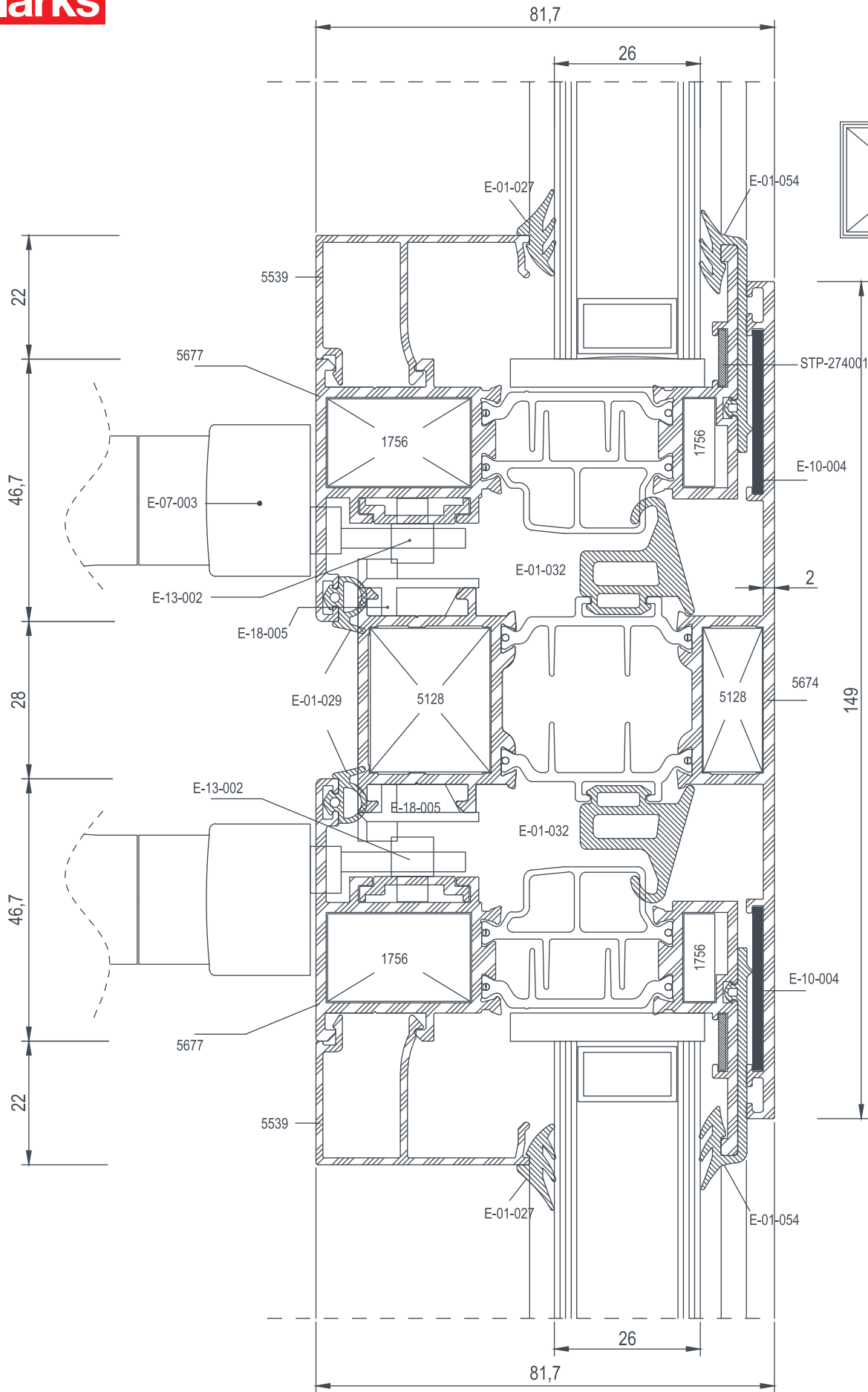



E 74

DEAYLAR / DETAILS

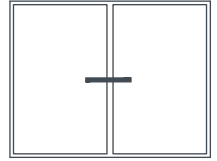
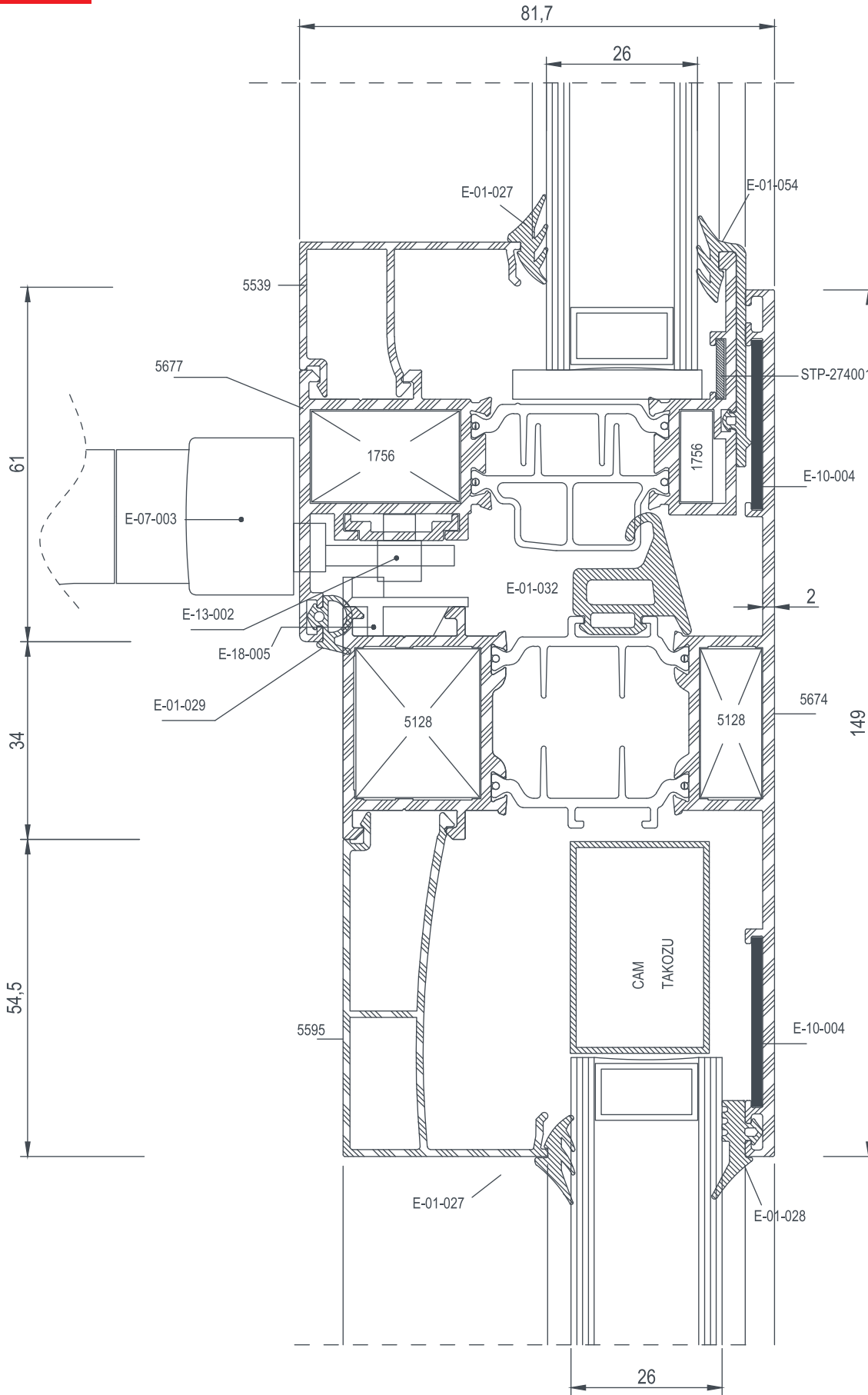



E 74

DEAYLAR / DETAILS

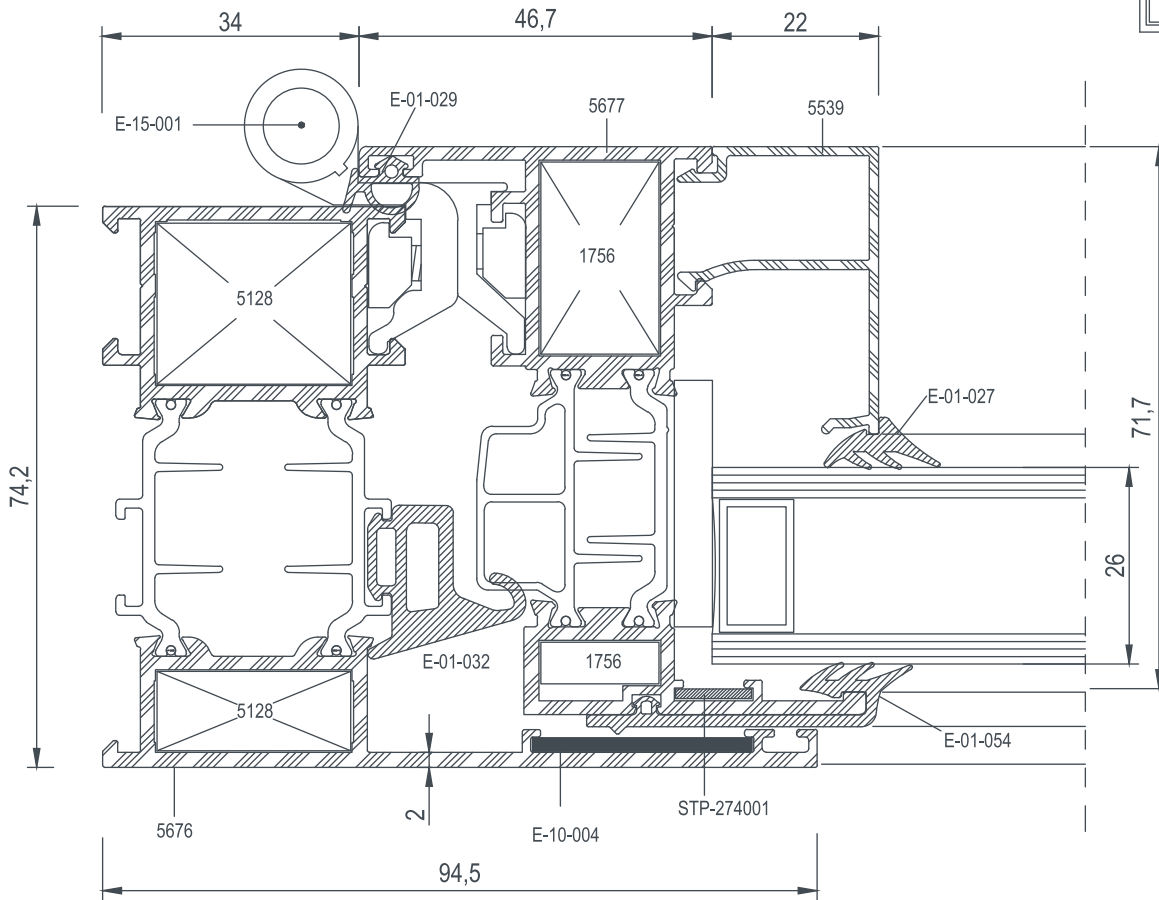
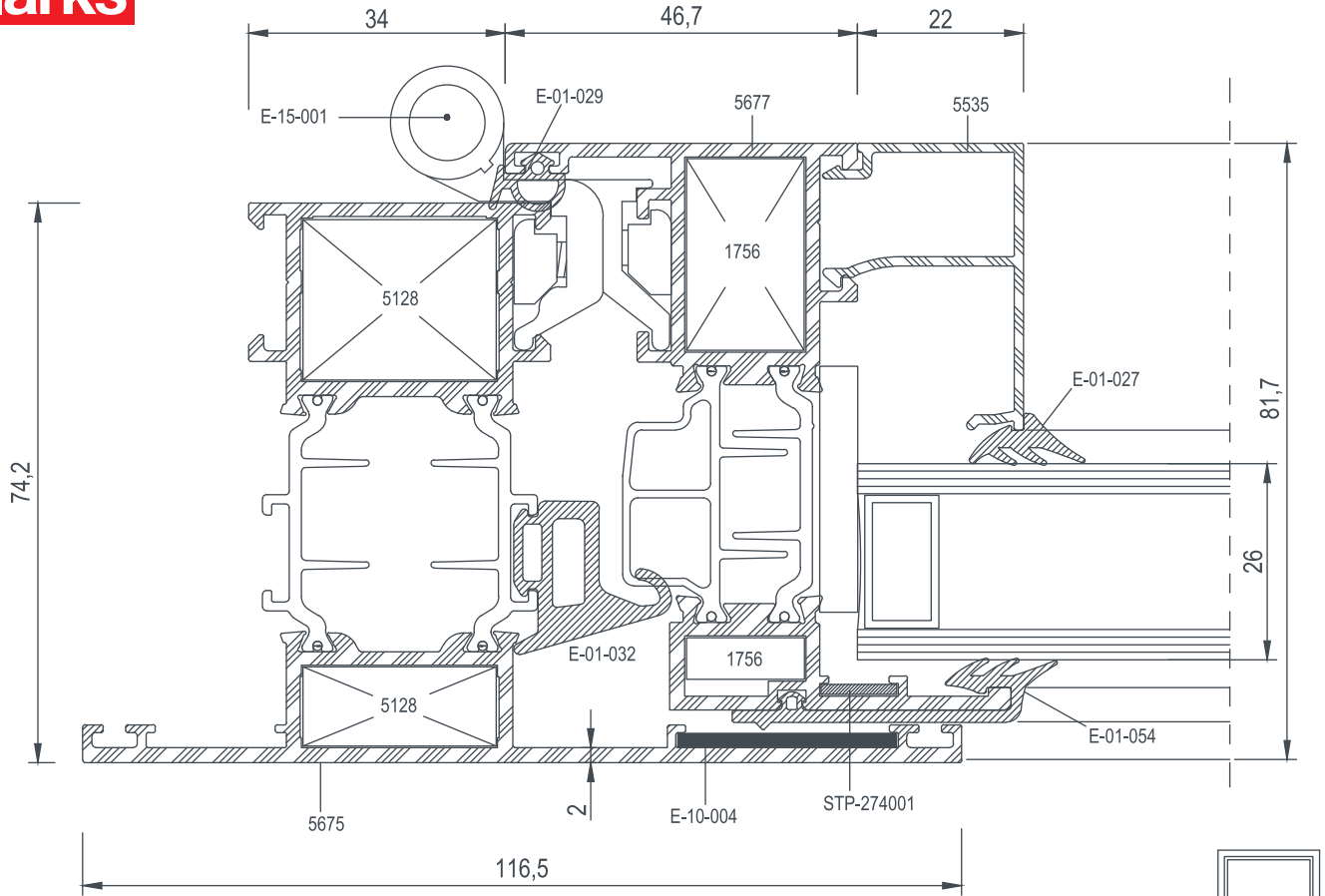

227





clarks

E 74









AKSESUARLAR
ACCESSORIES

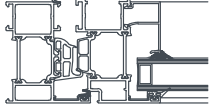

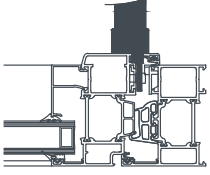

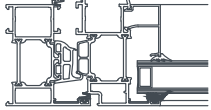
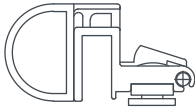
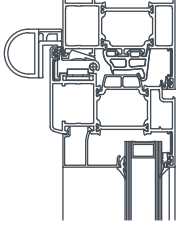
E 74

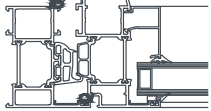
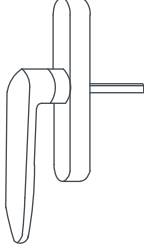
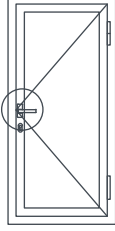
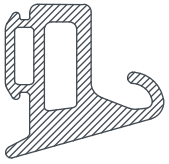
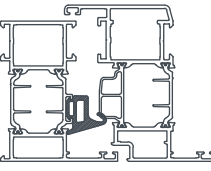
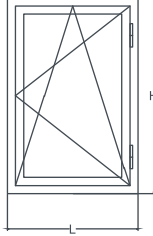
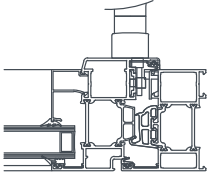

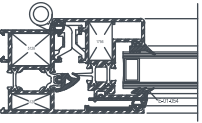
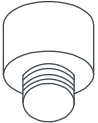
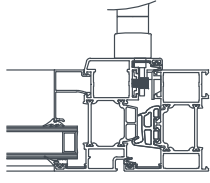



AKSESUARLAR / ACCESSORIES

	<p>E-01-027</p> <p>3mm iç cam fitili 3mm gasket</p> <p>45 gr/mt</p>			<p>E-07-003</p> <p>İspanyolet Kol Window handle</p>	
	<p>E-01-028</p> <p>Dış cam fitili outside gasket</p> <p>60 gr/mt</p>			<p>E-07-004</p> <p>Vasistas Mandal Vasistas Spring</p>	
	<p>E-01-029</p> <p>Dış Bini Fitili Acoustical Gasket</p> <p>40 gr/mt</p>			<p>E-07-005</p> <p>Kapı Kolu Door Handle</p>	
	<p>E-01-032</p> <p>Tozluk Fitili Central gasket</p> <p>276 gr/mt</p>			<p>E-07-006</p> <p>Çift Açılım Mekanizması Tilt and Turn Mechanism</p> <p>L: 570~1000 mm H: 400~1200 mm</p>	
	<p>E-01-054</p> <p>Gizli Kanat Fitili Secret Sash gasket</p> <p>165 gr/mt</p>			<p>E-13-002</p> <p>Tij Pimi Lock Pin</p>	

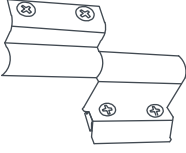
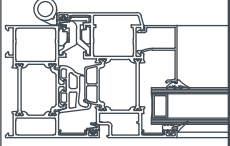

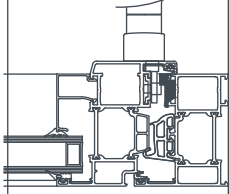
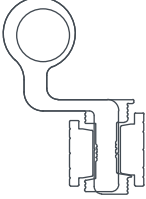
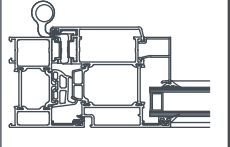
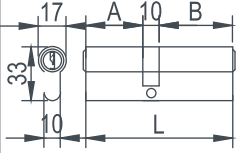
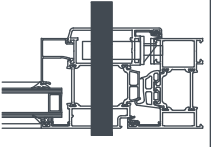
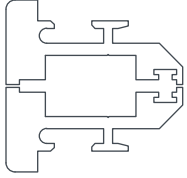
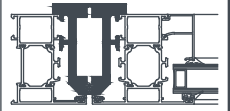
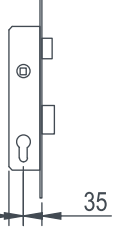
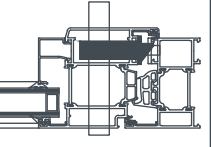
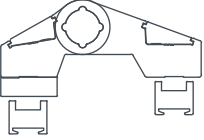
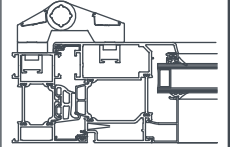
E 74

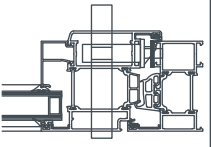
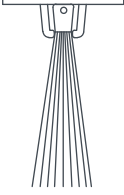
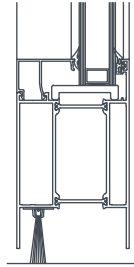
AKSESUARLAR / ACCESSORIES

	E-15-001 Pencere Menteşesi Window Hinge			E-18-005 Ayarlı Pim Karşılığı Lock Plate							
	E-15-004 Kapı Menteşesi Door Hinge		 <table border="1" data-bbox="940 1054 1077 1110"> <thead> <tr> <th>A</th> <th>B</th> <th>L</th> </tr> </thead> <tbody> <tr> <td>35</td> <td>65</td> <td>90</td> </tr> </tbody> </table>	A	B	L	35	65	90	E-18-011 Barel Cylinder	
A	B	L									
35	65	90									
	E-15-007 Pivot Menteşe Pivot Hinge			E-18-009 Dilli Kilit Mortise Lock							
	E-15-006 Kapı Menteşesi Door Hinge			E-18-008 Dilli Kilit Karşılığı Forend							
	E-17-003 Kapı Altı Fırçası Brush 1 Mt			E-23-002 Vasistas Makas Vasistas Accessory							



E 74

AKSESUARLAR / ACCESSORIES

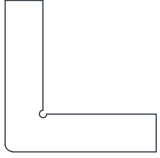
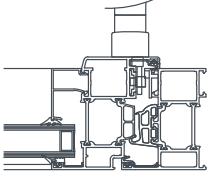
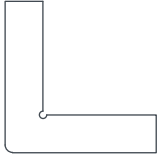
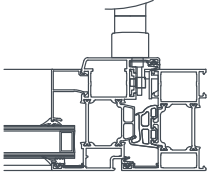
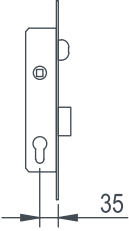
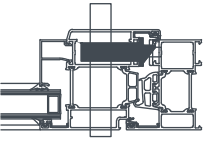
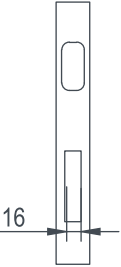
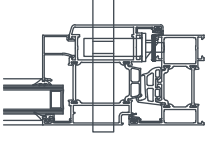
	<p>E-10-001 Köşe Çavuşu Corner joint</p>				
	<p>STP-274001 Köşe Çavuşu Corner joint</p>				
	<p>E-18-009-1 Makaralı Kilit Roller Lock</p>				
	<p>E-18-008-1 Makaralı Kilit Karşılığı Roller Forend Lock</p>				

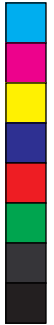

clarks

EDR 55



**EDR 55
ISI YALITIMSIZ PENCERE VE KAPI SİSTEMLERİ**

*EDR 55
NON-INSULATED WINDOWS & DOORS SYSTEMS*





EDR 55





PROFİL İNDEKS / PROFILE INDEX

COD Code	PROFİL KESİTİ Profile View	PROFİL AÇIKLAMASI Profile Description	AGIRLIK (kg/m) Weight	Jxx cm ⁴	Jyy cm ⁴	Wxx cm ³	Wyy cm ³
4312		KASA PROFİLİ FRAME PROFILE	0,945	13,30	3,54	4,00	1,50
4300		KASA PROFİLİ FRAME PROFILE	1,056	14,69	3,79	4,41	1,56
4313		KASA PROFİLİ FRAME PROFILE	1,067	17,42	9,30	4,53	2,74
4301		KASA PROFİLİ FRAME PROFILE	1,203	19,44	10,20	5,12	3,06
4314		KANAT PROFİLİ SASH PROFILE	1,031	21,45	3,80	4,80	1,94
4302		KANAT PROFİLİ SASH PROFILE	1,169	23,81	4,16	5,44	2,05
4315		KANAT PROFİLİ SASH PROFILE	1,178	29,11	9,53	5,90	3,30
4303		KANAT PROFİLİ SASH PROFILE	1,344	32,40	10,72	6,65	3,76
4316		KANAT PROFİLİ SASH PROFILE	1,460	59,80	26,70	9,02	6,36
4304		KANAT PROFİLİ SASH PROFILE	1,686	31,12	10,08	8,68	7,41
4316		ORTA KAYIT PROFİLİ MULLION PROFILE	1,174	15,03	8,24	4,68	2,40

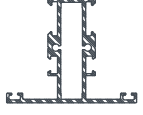
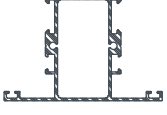
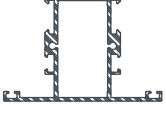
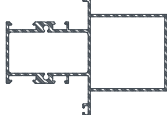
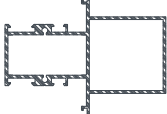

EDR 55

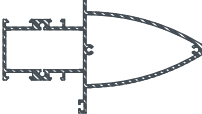
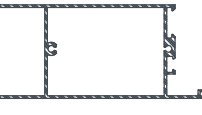
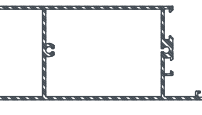
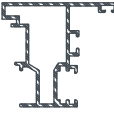









PROFİL İNDEKS / PROFILE INDEX

COD Code	PROFİL KESİTİ Profile View	PROFİL AÇIKLAMASI Profile Description	AGIRLIK (kg/m) Weight	Jxx cm4	Jyy cm4	Wxx cm3	Wyy cm3
4306		ORTA KAYIT PROFİLİ MULLION PROFILE	1,266	16,06	8,34	5,05	2,43
4319		ORTA KAYIT PROFİLİ MULLION PROFILE	1,293	18,26	18,11	5,76	4,33
4307		ORTA KAYIT PROFİLİ MULLION PROFILE	1,413	20,25	18,71	6,62	4,47
4320		TAKV.ORTA KAYIT PROFİLİ SUPPORTED MULLION PROFILE	1,921	71,62	28,92	12,90	6,98
4308		TAKV.ORTA KAYIT PROFİLİ SUPPORTED MULLION PROFILE	2,157	82,52	31,35	15,08	7,50
4321		TAKV.ORTA KAYIT PROFİLİ SUPPORTED MULLION PROFILE	2,084	114,24	26,07	14,56	6,23
4309		TAKV.ORTA KAYIT PROFİLİ SUPPORTED MULLION PROFILE	2,359	125,91	28,11	15,86	6,72
4322		ETEK PROFİLİ KICK PROFILE	1,593	74,24	28,22	11,23	8,35
4310		ETEK PROFİLİ KICK PROFILE	1,840	84,34	32,96	12,88	9,71
4311		ÇİFT KANAT ADAPTÖR PROF. DOUBLE SASH ADAPTER PROFILE	1,096	15,35	8,11	4,61	2,54
2505		KÖŞE DÖNÜŞ PROFİLİ CORNER PROFILE	0,619	6,72	6,72	2,70	2,70



EDR 55

PROFİL İNDEKS / PROFILE INDEX

COD Code	PROFİL KESİTİ Profile View	PROFİL AÇIKLAMASI Profile Description	AGIRLIK (kg/m) Weight	Jxx cm4	Jyy cm4	Wxx cm3	Wyy cm3
5337		ADAPTÖR PROFİLİ ADAPTER PROFILE	0,151	----	----	----	----
5339		ADAPTÖR PROFİLİ ADAPTER PROFILE	0,374	5,31	0,40	1,60	0,30
5117		TİJ PROFİLİ SASH PROFILE	0,105	----	----	----	----
5572		TİJ PROFİLİ (BOYALI PROFİLLER İÇİN) PAINTED SASH PROFILE	0,100	----	----	----	----
4543		ADAPTÖR PROFİLİ ADAPTER PROFILE	0,456	4,97	0,20	1,76	0,22
5118		CAM ÇİTASI PROFİLİ GLAZING BEAD	0,249	----	----	----	----
5119		CAM ÇİTASI PROFİLİ GLAZING BEAD	0,251	----	----	----	----
5120		CAM ÇİTASI PROFİLİ GLAZING BEAD	0,255	----	----	----	----
5121		CAM ÇİTASI PROFİLİ GLAZING BEAD	0,260	----	----	----	----
5122		CAM ÇİTASI PROFİLİ GLAZING BEAD	0,267	----	----	----	----
5123		CAM ÇİTASI PROFİLİ GLAZING BEAD	0,274	----	----	----	----



EDR 55

PROFİL İNDEKS / PROFILE INDEX

COD Code	PROFİL KESİTİ Profile View	PROFİL AÇIKLAMASI Profile Description	AGIRLIK (kg/m) Weight	Jxx cm4	Jyy cm4	Wxx cm3	Wyy cm3
5124		CAM ÇITASI PROFİLİ GLAZING BEAD	0,281	----	----	----	----
5125		CAM ÇITASI PROFİLİ GLAZING BEAD	0,292	----	----	----	----
5526		CAM ÇITASI PROFİLİ GLAZING BEAD	0,308	----	----	----	----
5535		CAM ÇITASI PROFİLİ GLAZING BEAD	0,305	----	----	----	----
5536		CAM ÇITASI PROFİLİ GLAZING BEAD	0,312	----	----	----	----
5537		CAM ÇITASI PROFİLİ GLAZING BEAD	0,318	----	----	----	----
5538		CAM ÇITASI PROFİLİ GLAZING BEAD	0,325	----	----	----	----
5539		CAM ÇITASI PROFİLİ GLAZING BEAD	0,331	----	----	----	----
5127		KÖŞE TAKOZ PROFİLİ CORNER JOINT	3,484	----	----	----	----
5128		KÖŞE TAKOZ PROFİLİ CORNER JOINT	3,652	----	----	----	----
4542		KÖŞE TAKOZ PROFİLİ CORNER JOINT	5,381	----	----	----	----

clarks

EDR 55

PROFİLLER *PROFILES*

EDR 55 - 1.5 - 1.8T ISI YALITIMSIZ SERİ
EDR 55 - 1.5 - 1.8T NON-INSULATION SERIES





EDR 55

PROFİLLER / PROFILES

COD Code	AGIRLIK (kg/m) Weight	Jxx cm4	Jyy cm4	Wxx cm3	Wyy cm3	L m
4312	0,945	13,30	3,54	4,00	1,50	6
4300	1,056	14,69	3,79	4,41	1,56	6
4313	1,067	17,42	9,30	4,53	2,74	6
4301	1,203	19,44	10,20	5,12	3,06	6

4312

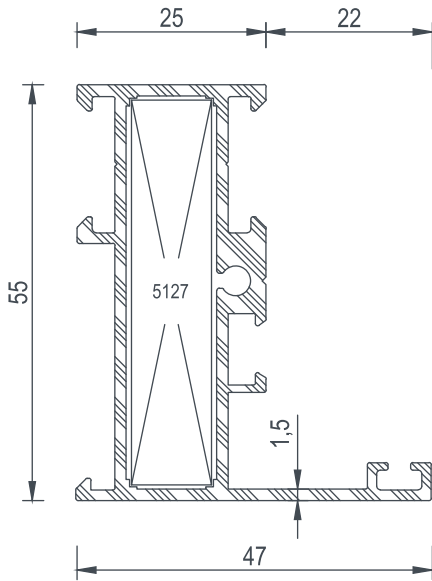

4300

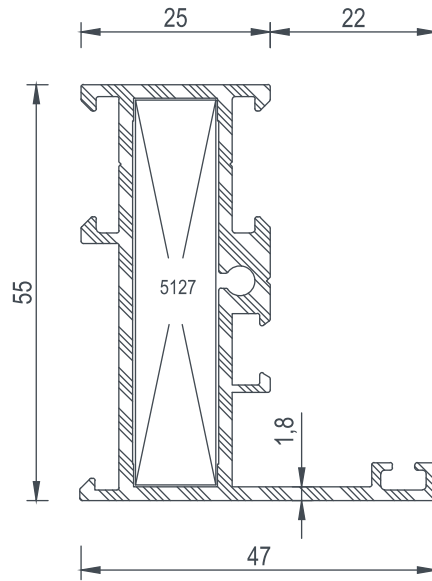

4313

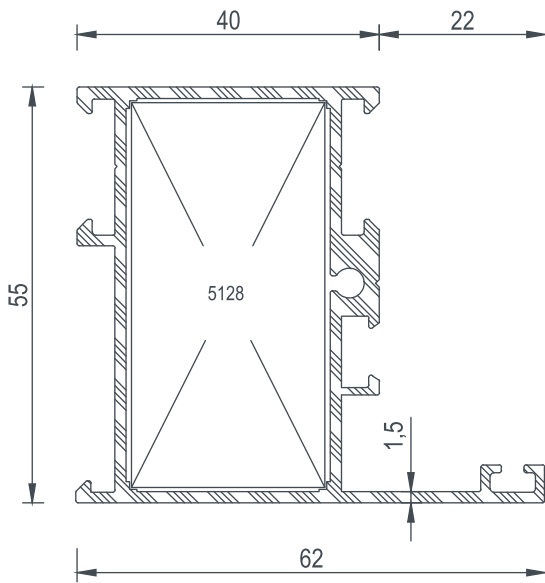

4301

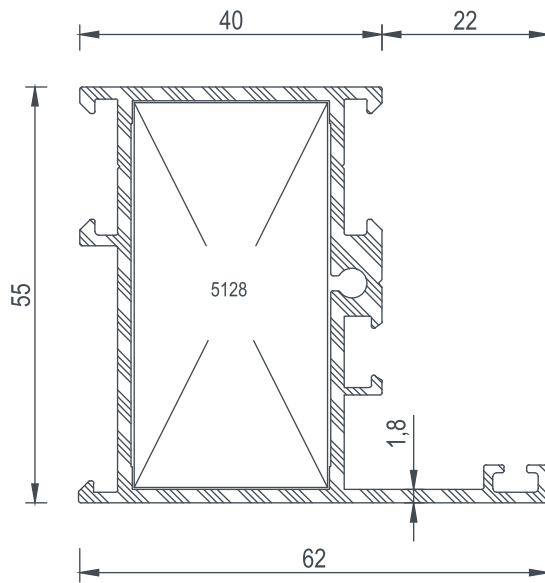



EDR 55

PROFILLER / PROFILES

COD Code	AGIRLIK (kg/m) Weight	Jxx cm4	Jyy cm4	Wxx cm3	Wyy cm3	L m
4314	1,031	21,45	3,80	4,80	1,94	6
4302	1,169	23,81	4,16	5,44	2,05	6
4315	1,178	29,11	9,53	5,90	3,30	6
4303	1,344	32,40	10,72	6,65	3,76	6

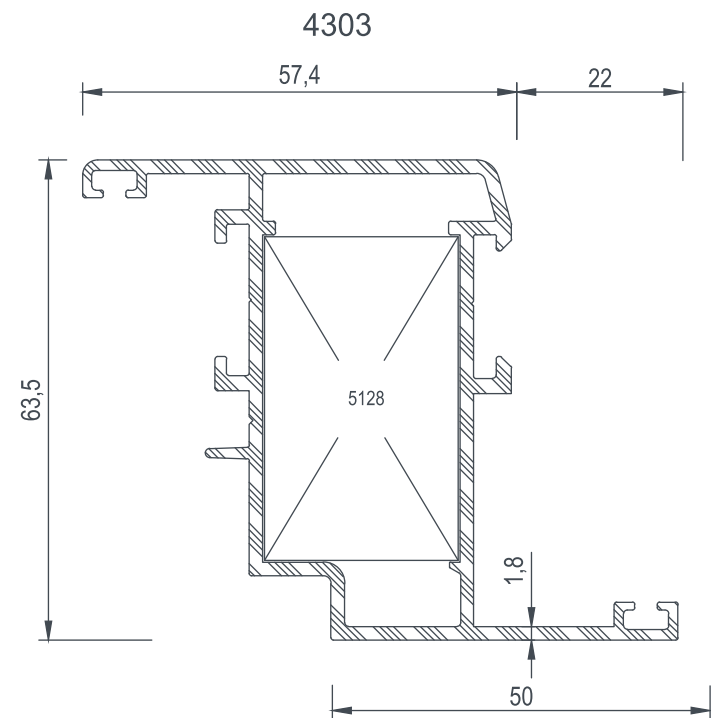
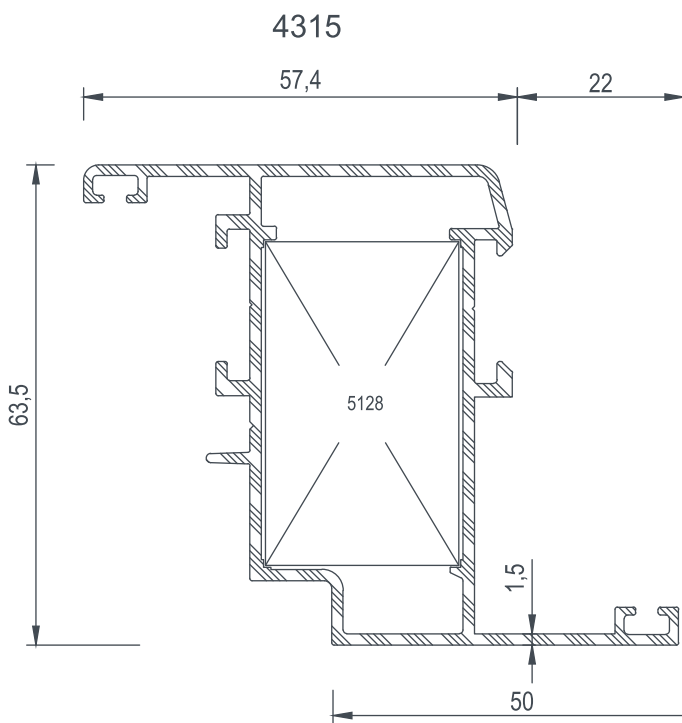
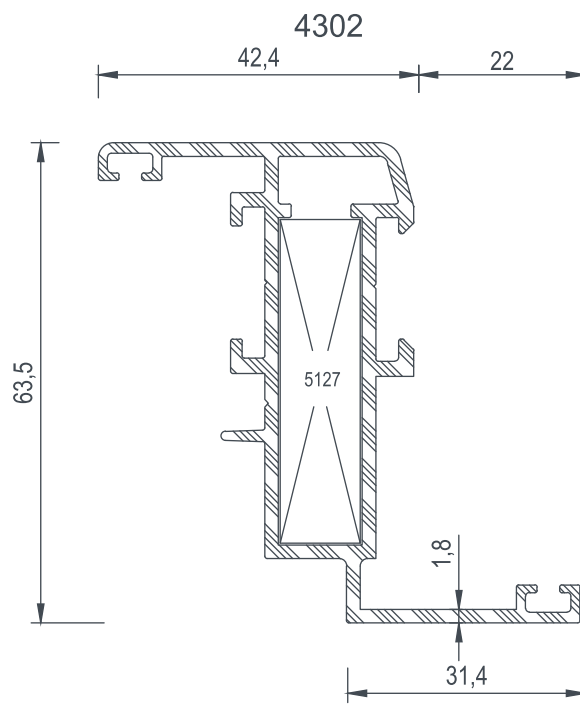
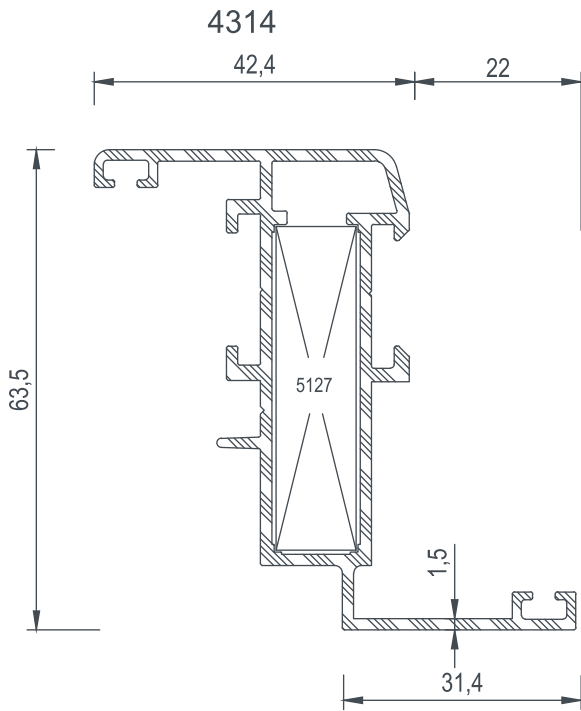



EDR 55

PROFİLLER / PROFILES

COD Code	AGIRLIK (kg/m) Weight	Jxx cm4	Jyy cm4	Wxx cm3	Wyy cm3	L m
4316	1,460	59,80	26,70	9,02	6,36	6
4304	1,686	66,61	31,12	10,08	7,41	6

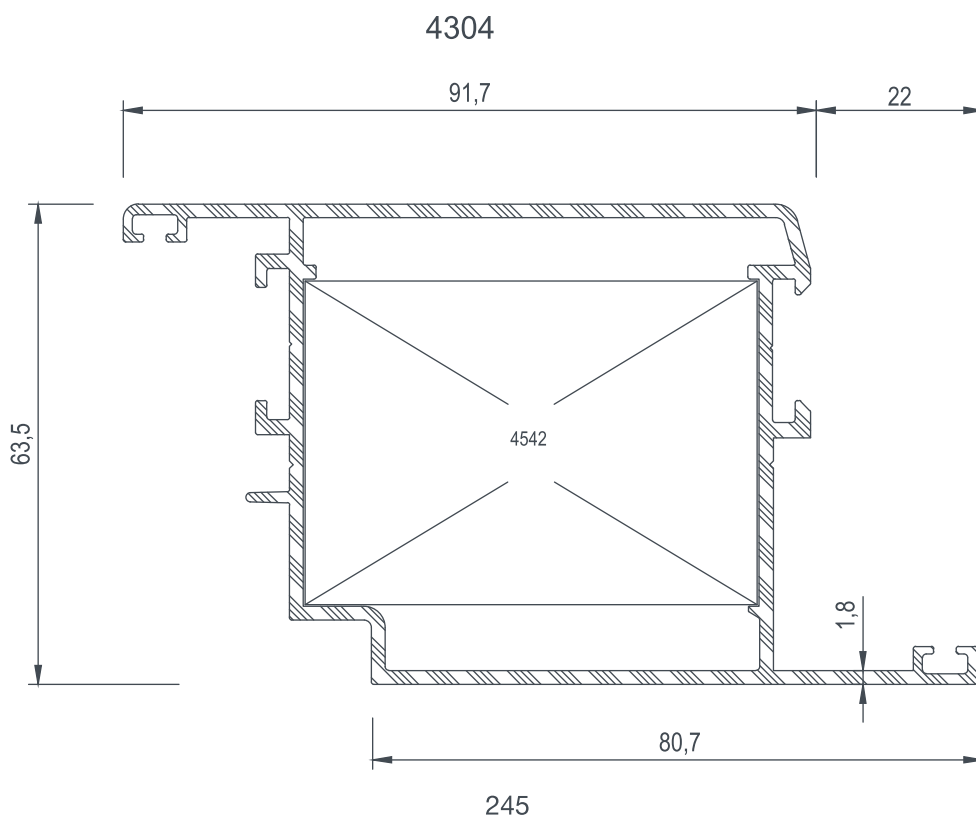
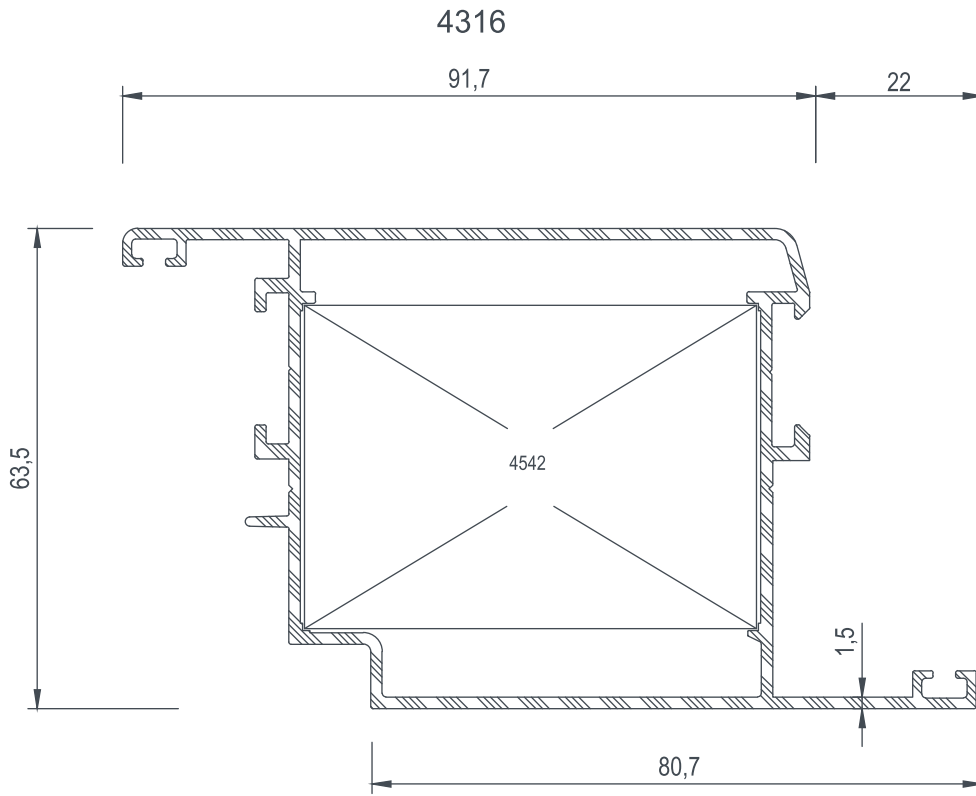



EDR 55

PROFİLLER / PROFILES

COD Code	AGIRLIK (kg/m) Weight	Jxx cm4	Jyy cm4	Wxx cm3	Wyy cm3	L m
4317	1,488	56,58	32,64	9,87	8,46	6
4305	1,706	62,67	37,60	10,98	9,85	6

4317

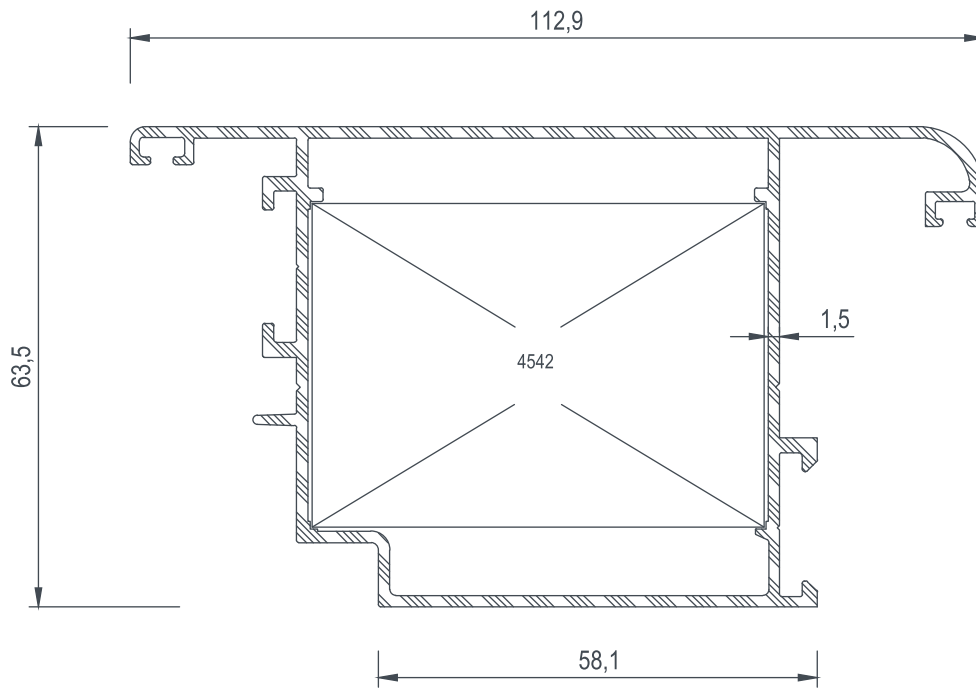

4305

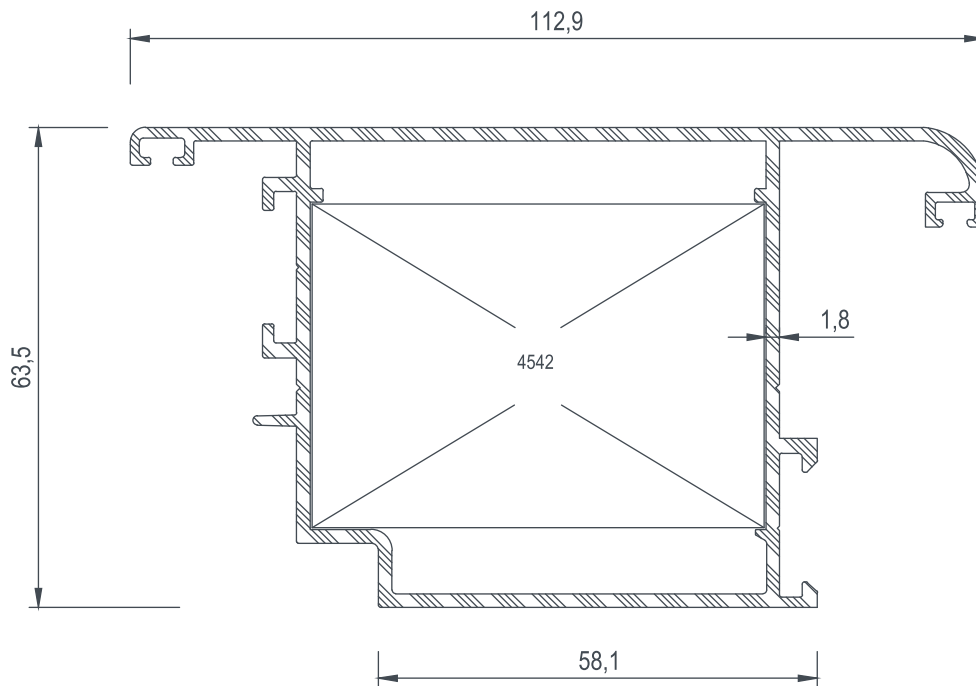

246





EDR 55

PROFİLLER / PROFILES

COD Code	AGIRLIK (kg/m) Weight	Jxx cm ⁴	Jyy cm ⁴	Wxx cm ³	Wyy cm ³	L m
4318	1,174	15,03	8,24	4,68	2,40	6
4306	1,266	16,06	8,34	5,05	2,43	6
4319	1,293	18,26	18,11	5,76	4,33	6
4307	1,413	20,25	18,71	6,62	4,47	6

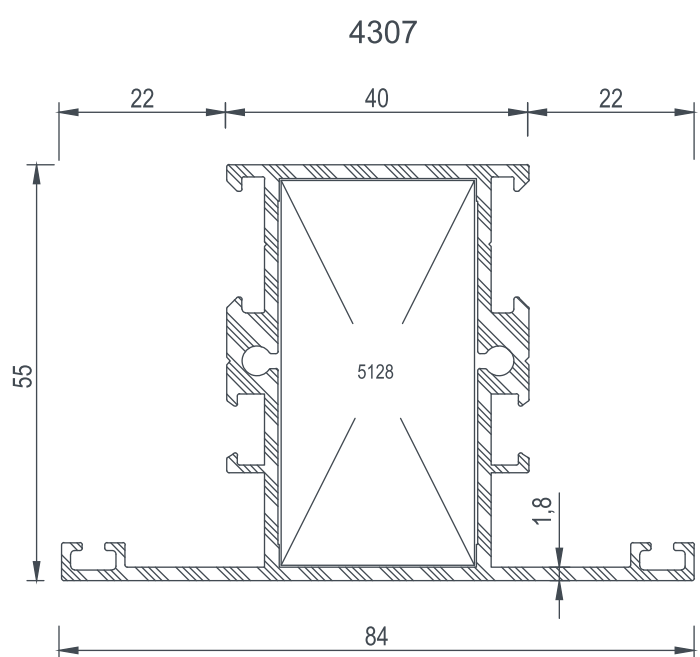
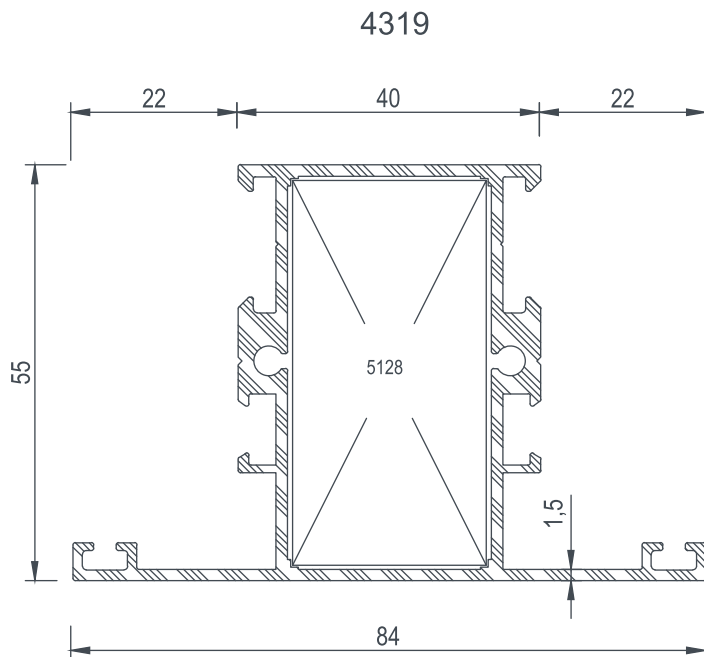
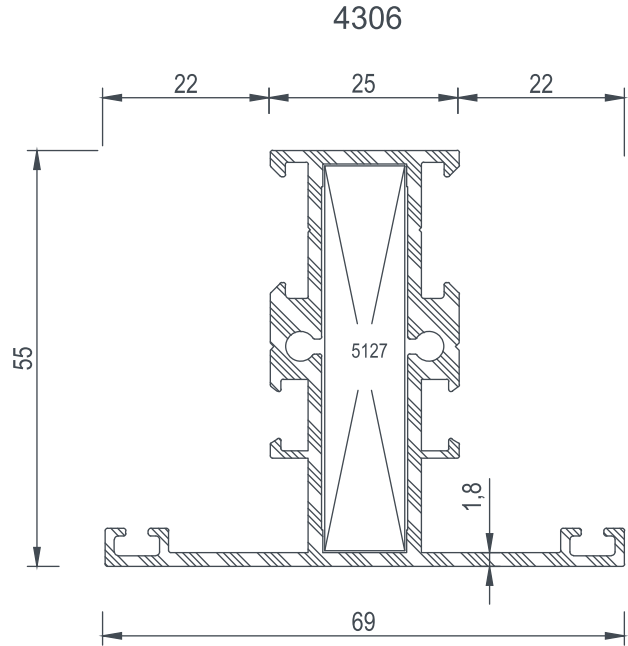
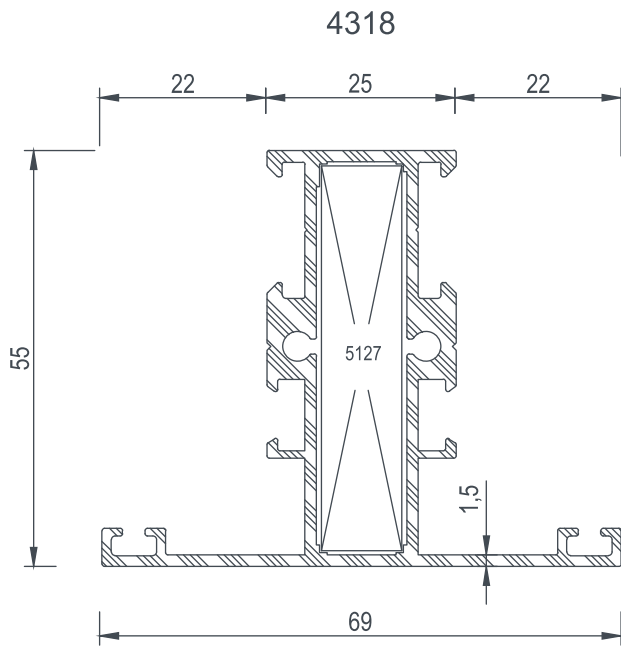



EDR 55

PROFİLLER / PROFILES

COD Code	AGIRLIK (kg/m) Weight	Jxx cm ⁴	Jyy cm ⁴	Wxx cm ³	Wyy cm ³	L m
4320	1,921	71,62	28,92	12,90	6,91	6
4308	2,157	82,52	31,35	15,08	7,50	6

4320

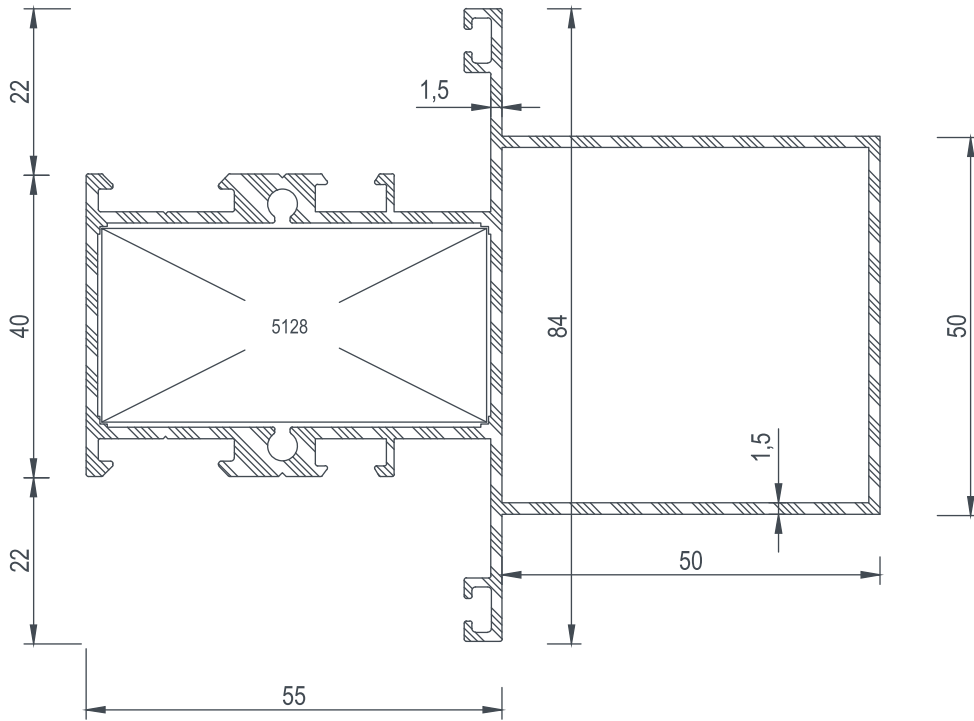

4308

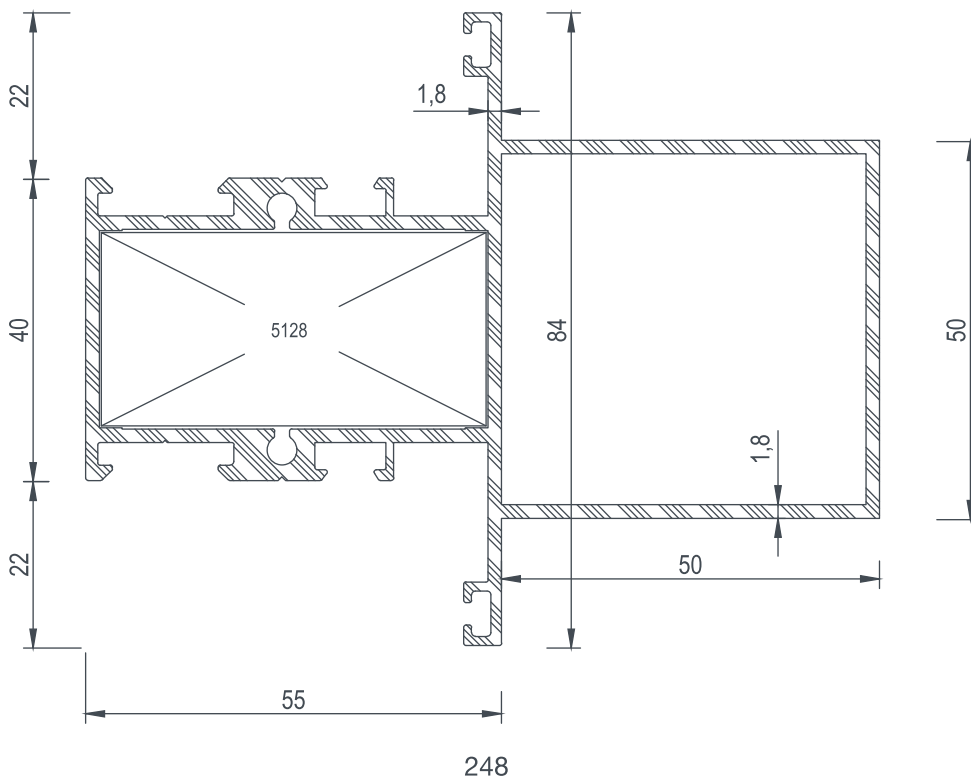



EDR 55

PROFILLER / PROFILES

COD Code	AGIRLIK (kg/m) Weight	Jxx cm ⁴	Jyy cm ⁴	Wxx cm ³	Wyy cm ³	L m
4321	2,084	114,24	26,07	14,56	6,23	6
4309	2,359	125,91	28,11	15,86	6,72	6

4321

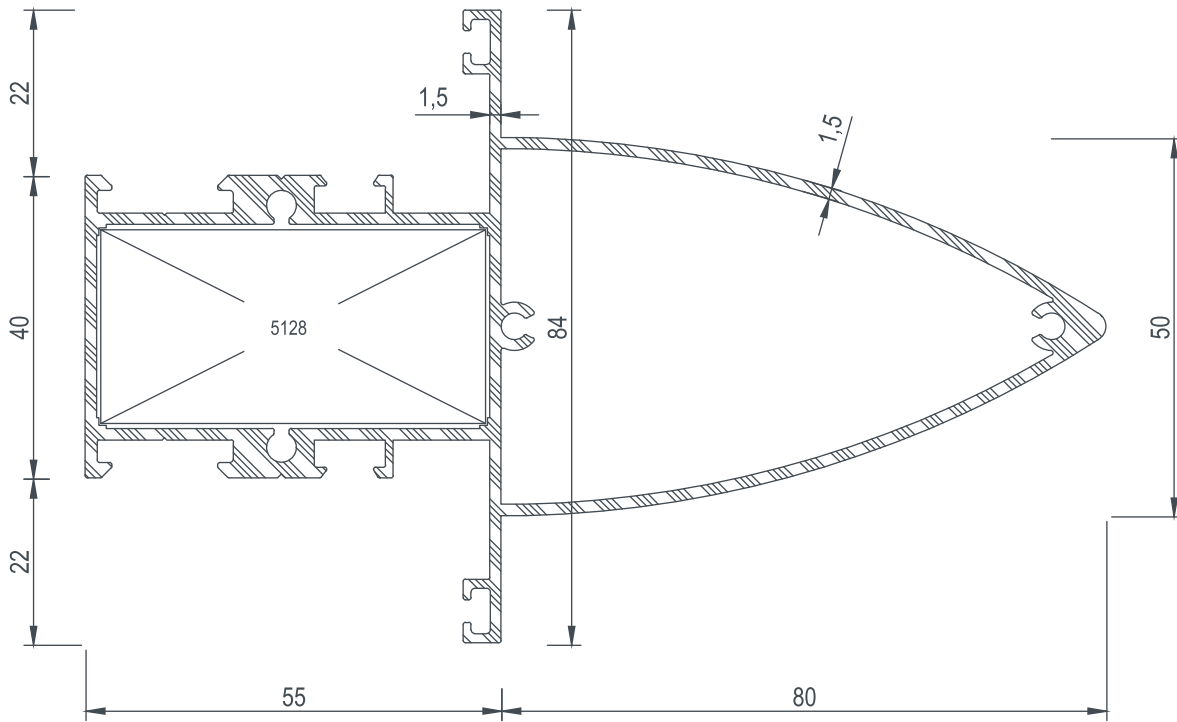

4309

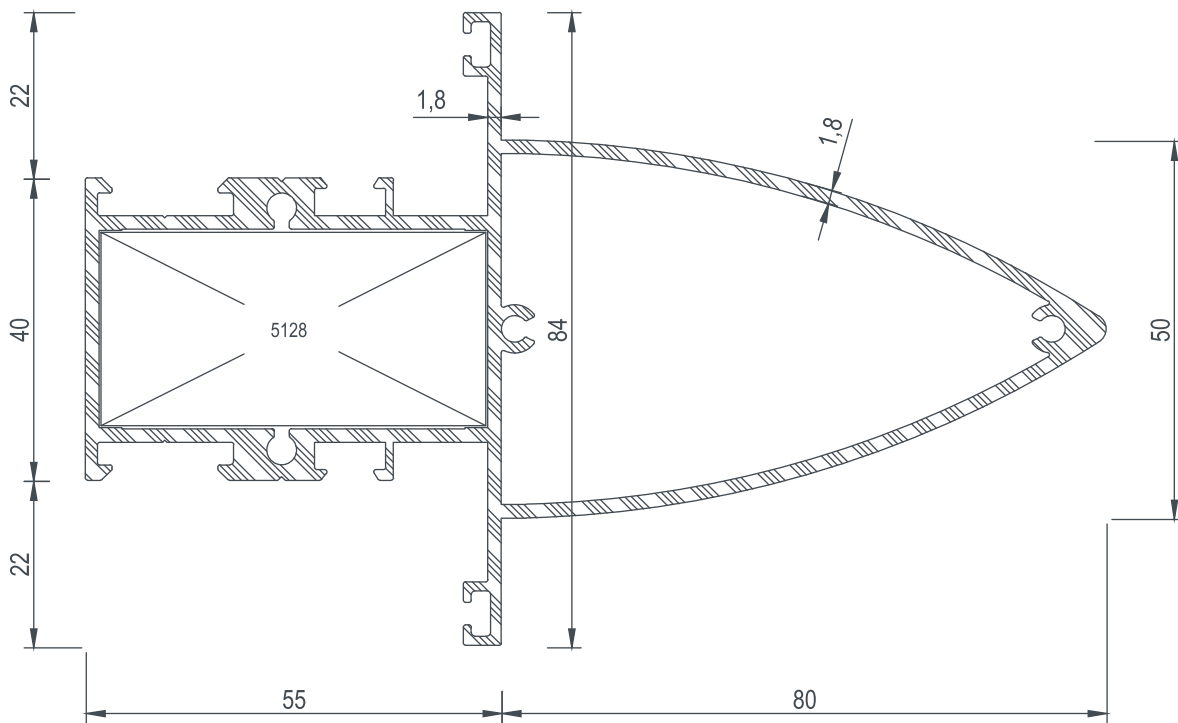

249





EDR 55

PROFİLLER / PROFILES

COD Code	AGIRLIK (kg/m) Weight	Jxx cm ⁴	Jyy cm ⁴	Wxx cm ³	Wyy cm ³	L m
4322	1,593	74,24	28,22	11,23	8,35	6
4310	1,840	84,34	32,96	12,88	9,71	6

4322

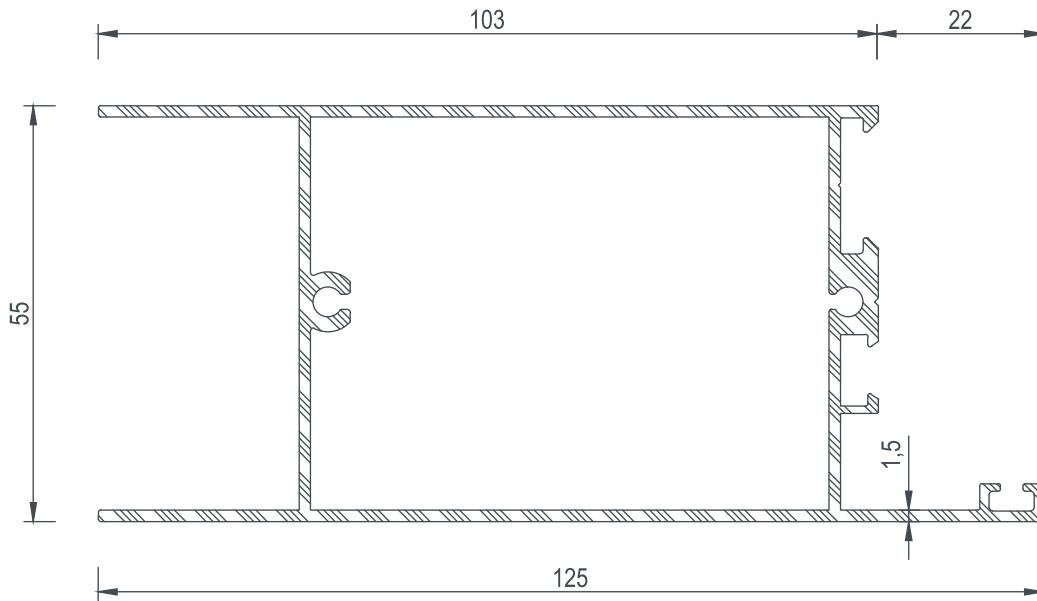

4310

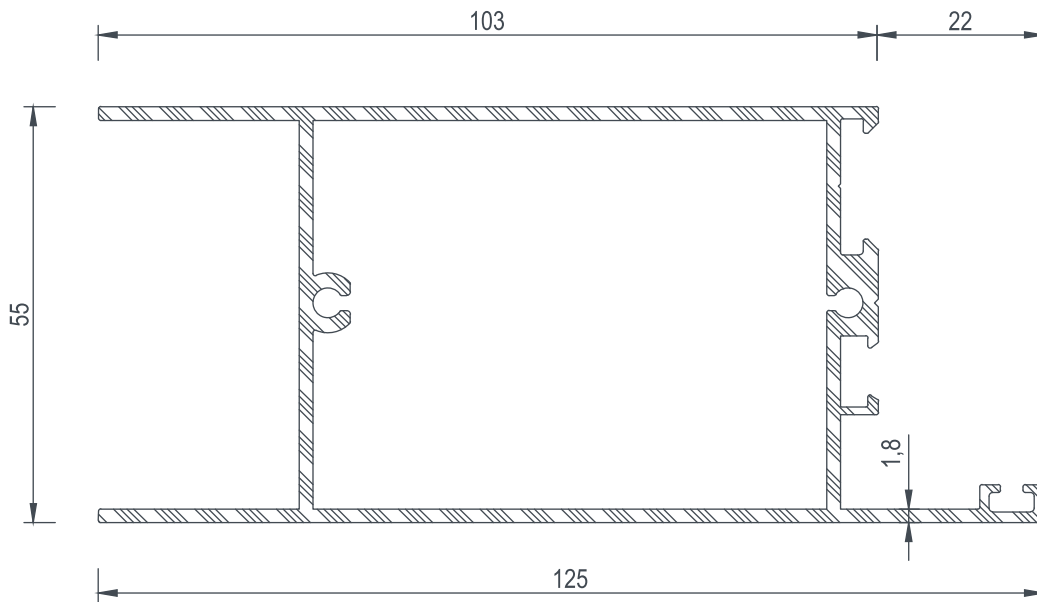



EDR 55

PROFİLLER / PROFILES

COD Code	AGIRLIK (kg/m) Weight	Jxx cm4	Jyy cm4	Wxx cm3	Wyy cm3	L m
4311	1,096	15,35	8,11	4,61	2,54	6
2505	0,619	6,72	6,72	2,70	2,70	6
5337	0,151	----	----	----	----	6
5339	0,374	5,31	0,40	1,60	0,30	6
5117	0,105	----	----	----	----	6
5572	0,100	----	----	----	----	6
4543	0,456	4,97	0,20	1,76	0,22	6

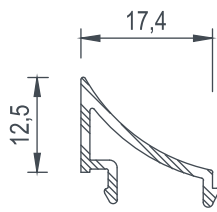
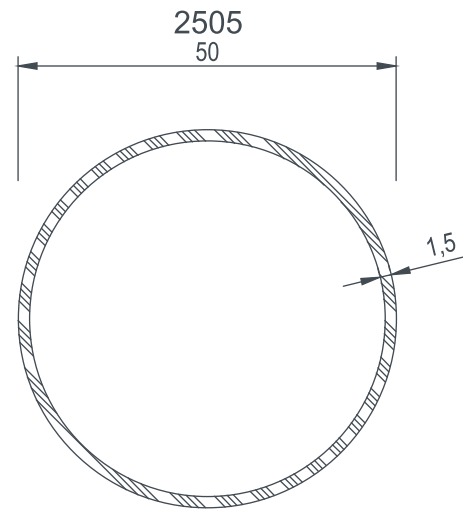
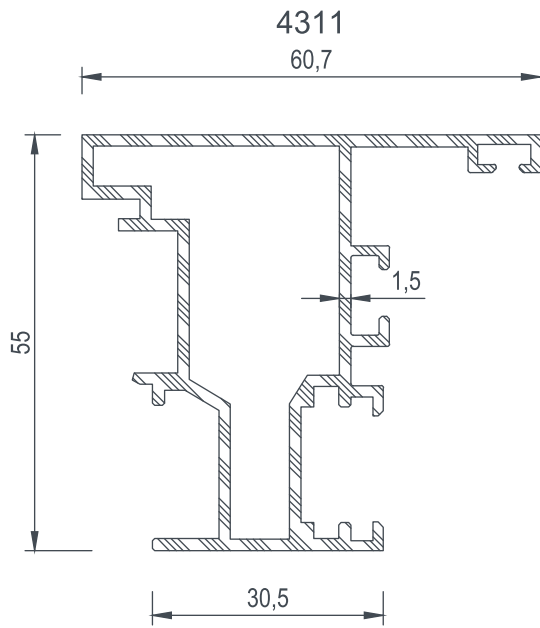

5337

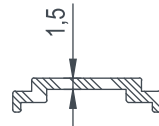

19,5

5117

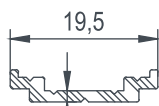

5572

(BOYALI TİJ PROFİLİ)

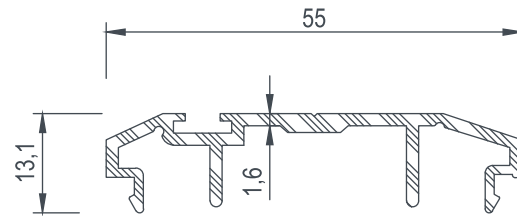

4543

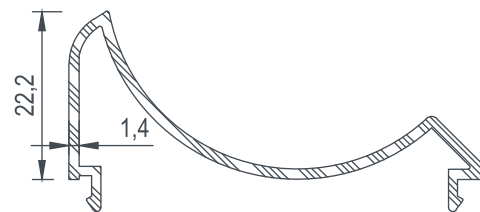

55

5339



EDR 55

PROFİLLER / PROFILES

COD Code	AGIRLIK (kg/m) Weight	Jxx cm4	Jyy cm4	Wxx cm3	Wyy cm3	L m
5118	0,249	-----	-----	-----	-----	6
5119	0,251	-----	-----	-----	-----	6
5120	0,254	-----	-----	-----	-----	6
5121	0,259	-----	-----	-----	-----	6
5122	0,267	-----	-----	-----	-----	6
5123	0,274	-----	-----	-----	-----	6
5124	0,281	-----	-----	-----	-----	6
5125	0,292	-----	-----	-----	-----	6
5126	0,308	-----	-----	-----	-----	6
5535	0,305	-----	-----	-----	-----	6

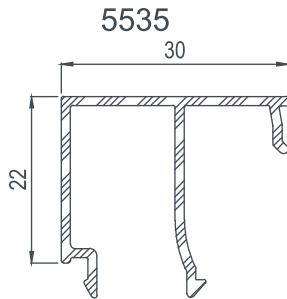
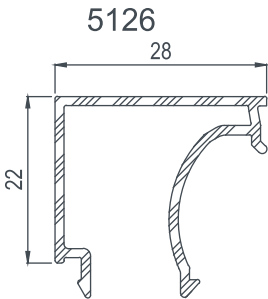
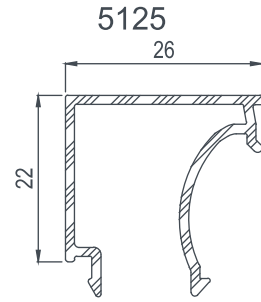
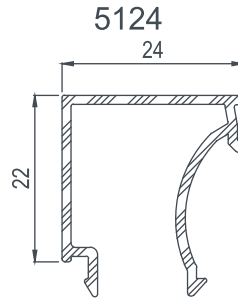
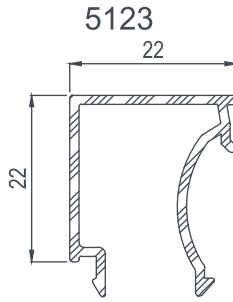
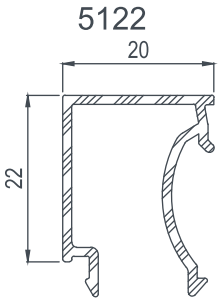
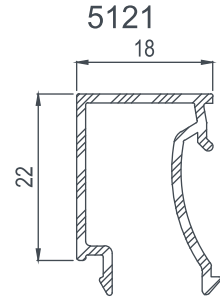
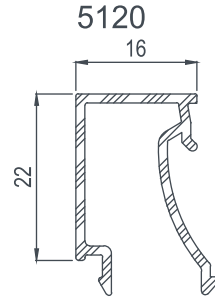
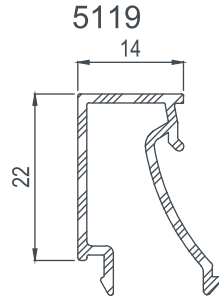
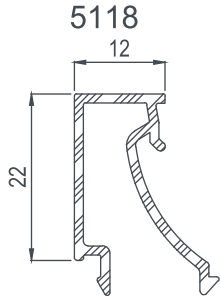

CAM ÇİTASI Glazing Bead	İÇ CAM FİTİLİ Glazing Gasket (in)	CAM KALINLIĞI Glas Thickness	DIŞ CAM FİTİLİ Glazing Gasket (out)
5118	E-01-027	40 mm	E-01-028
5119	E-01-027	38 mm	E-01-028
5120	E-01-027	36 mm	E-01-028
5121	E-01-027	34 mm	E-01-028
5122	E-01-027	32 mm	E-01-028
5123	E-01-027	30 mm	E-01-028
5124	E-01-027	28 mm	E-01-028
5125	E-01-027	26 mm	E-01-028
5126	E-01-027	24 mm	E-01-028
5535	E-01-027	22 mm	E-01-028



EDR 55

PROFİLLER / PROFILES

COD Code	AGIRLIK (kg/m) Weight	Jxx cm4	Jyy cm4	Wxx cm3	Wyy cm3	L m
5536	0,312	-----	-----	-----	-----	6
5537	0,318	-----	-----	-----	-----	6
5538	0,325	-----	-----	-----	-----	6
5539	0,331	-----	-----	-----	-----	6

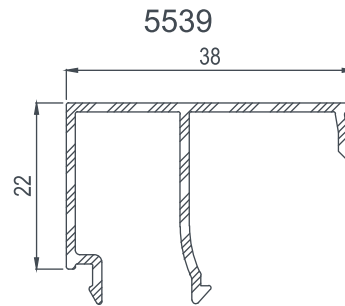
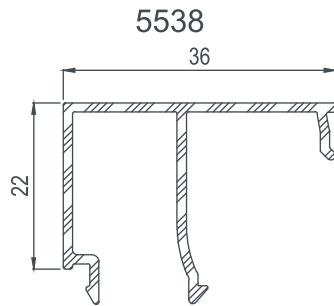
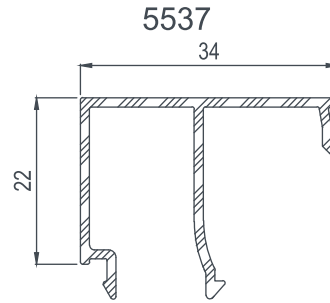
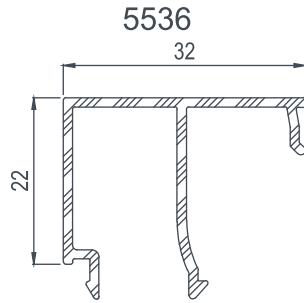

CAM ÇİTASI Glazing Bead	İÇ CAM FİTİLİ Glazing Gasket (in)	CAM KALINLIĞI Glas Thickness	DIŞ CAM FİTİLİ Glazing Gasket (out)
5536	E-01-027	20 mm	E-01-028
5537	E-01-027	18 mm	E-01-028
5538	E-01-027	16 mm	E-01-028
5539	E-01-027	14 mm	E-01-028



EDR 55

PROFİLLER / PROFILES

COD Code	AGIRLIK (kg/m) Weight	Jxx cm ⁴	Jyy cm ⁴	Wxx cm ³	Wyy cm ³	L m
5127	3,484	---	---	---	---	6

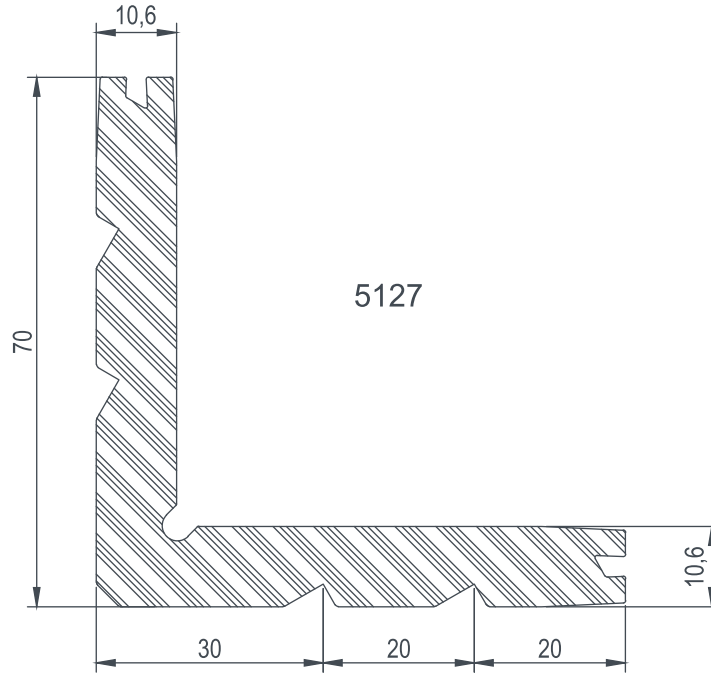

KÖŞE TAKOZLARI / Corner Cleats

Nr	L m	AKS. KODU Acs. Code	KESİM ÖLÇÜSÜ Cutting Size
4300	5127	5127-50,9	50,9 mm
4302	5127	5127-42,8	42,8 mm
4306	5127	5127-50,9	50,9 mm
4312	5127	5127-50,9	50,9 mm
4314	5127	5127-42,8	42,8 mm
4318	5127	5127-50,9	50,9 mm



EDR 55

PROFİLLER / PROFILES

COD Code	AGIRLIK (kg/m) Weight	Jxx cm ⁴	Jyy cm ⁴	Wxx cm ³	Wyy cm ³	L m
5128	3,652	---	---	---	---	6

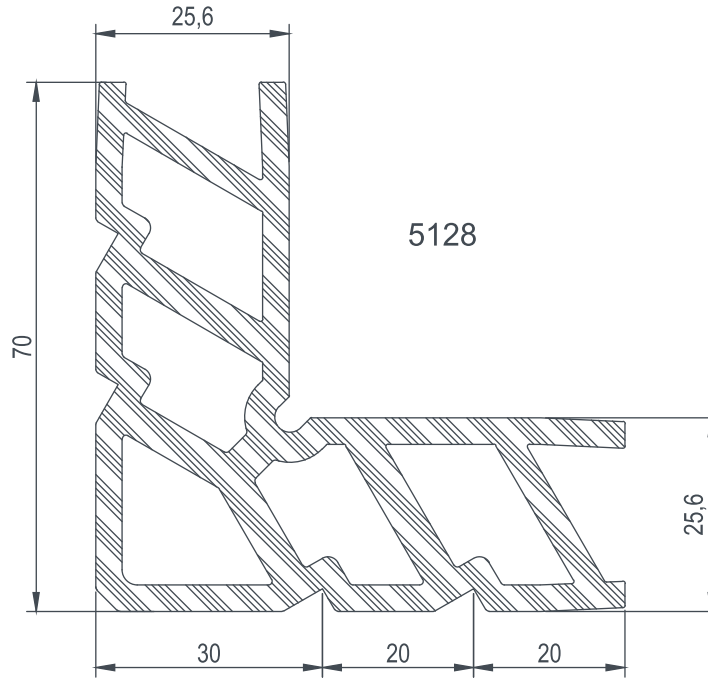

KÖŞE TAKOZLARI / Corner Cleats

Nr	AKS. KODU Acs. Code	KESİM ÖLÇÜSÜ Cutting Size
4301	5128-50,9	50,9 mm
4303	5128-42,8	42,8 mm
4307	5128-50,9	50,9 mm
4308	5128-50,9	50,9 mm
4309	5128-50,9	50,9 mm
4313	5128-50,9	50,9 mm
4315	5128-42,8	42,8 mm
4319	5128-50,9	50,9 mm
4320	5128-50,9	50,9 mm
4321	5128-50,9	50,9 mm



EDR 55

PROFİLLER / PROFILES

COD Code	AGIRLIK (kg/m) Weight	Jxx cm ⁴	Jyy cm ⁴	Wxx cm ³	Wyy cm ³	L m
4542	5,381	---	---	---	---	6

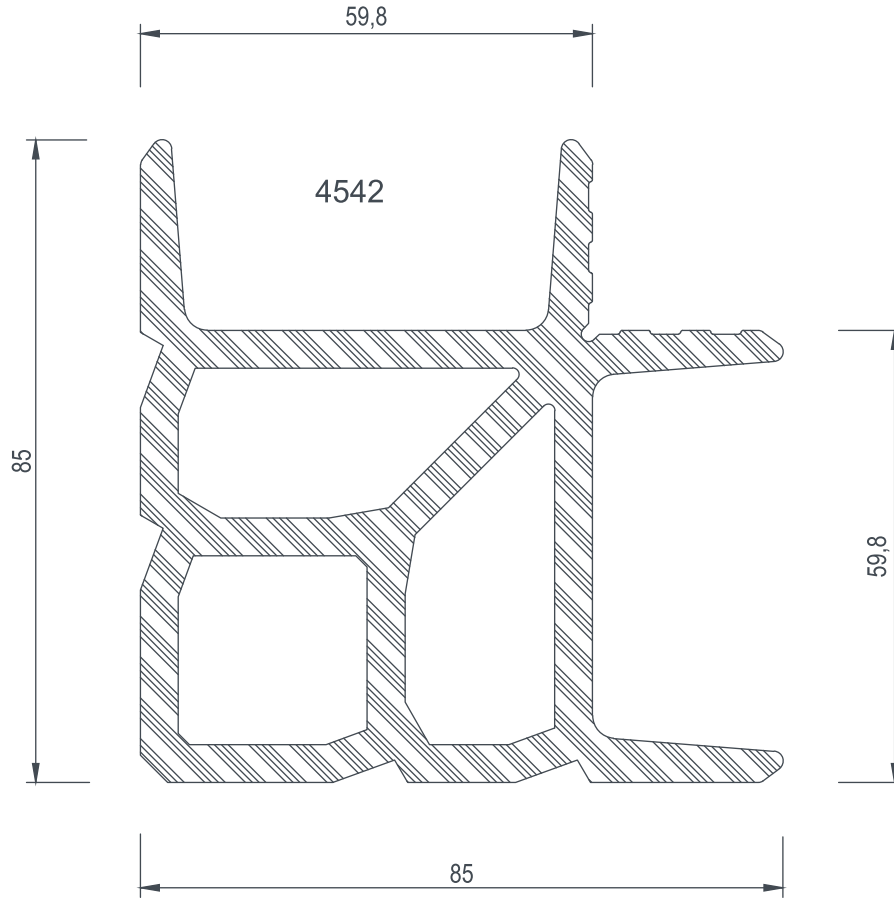

KÖŞE TAKOZLARI / Corner Cleats

Nr	AKS. KODU Acs. Code	KESİM ÖLÇÜSÜ Cutting Size
4304	4542-42,8	42,8 mm
4305	4542-42,8	42,8 mm
4316	4542-42,8	42,8 mm
4317	4542-42,8	42,8 mm

clarks

EDR 55

DETAYLAR
DETAILS





EDR 55

DETAYLAR / DETAILS

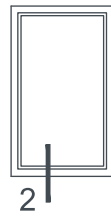
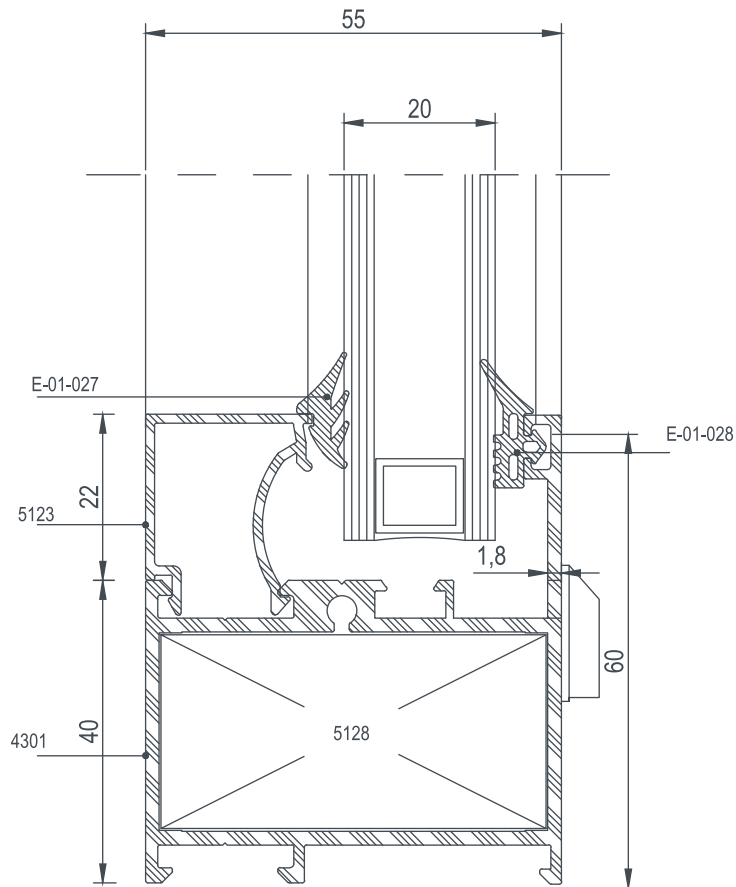
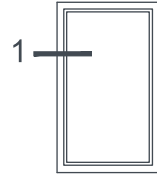
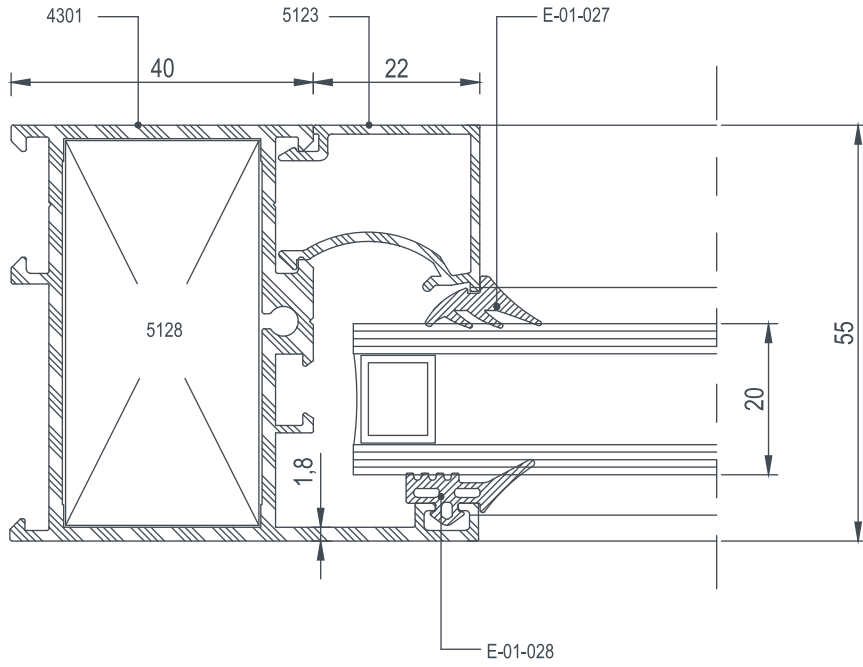



EDR 55

DETAYLAR / DETAILS

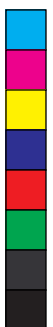
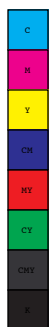
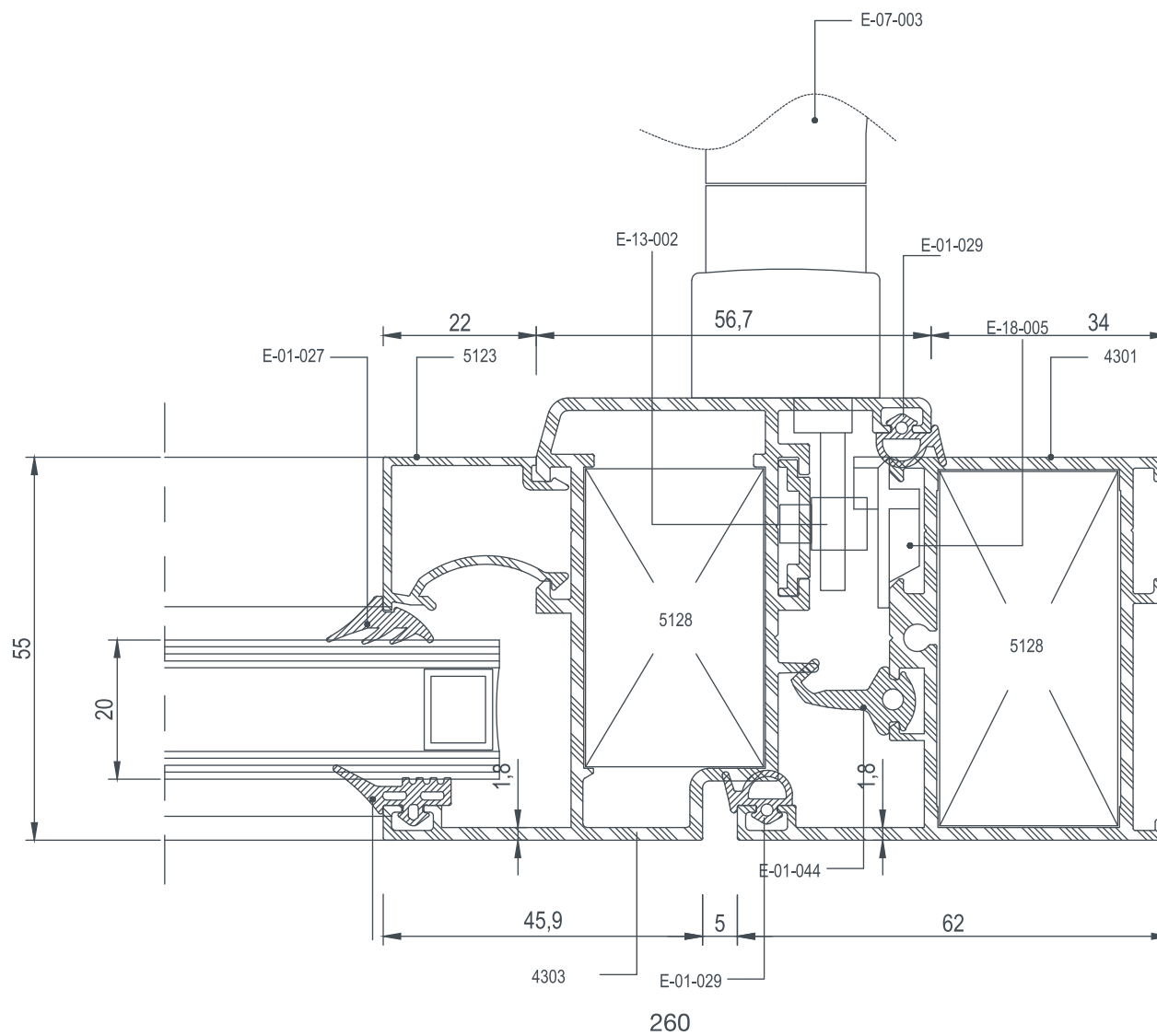
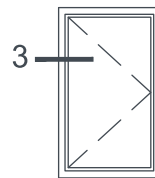
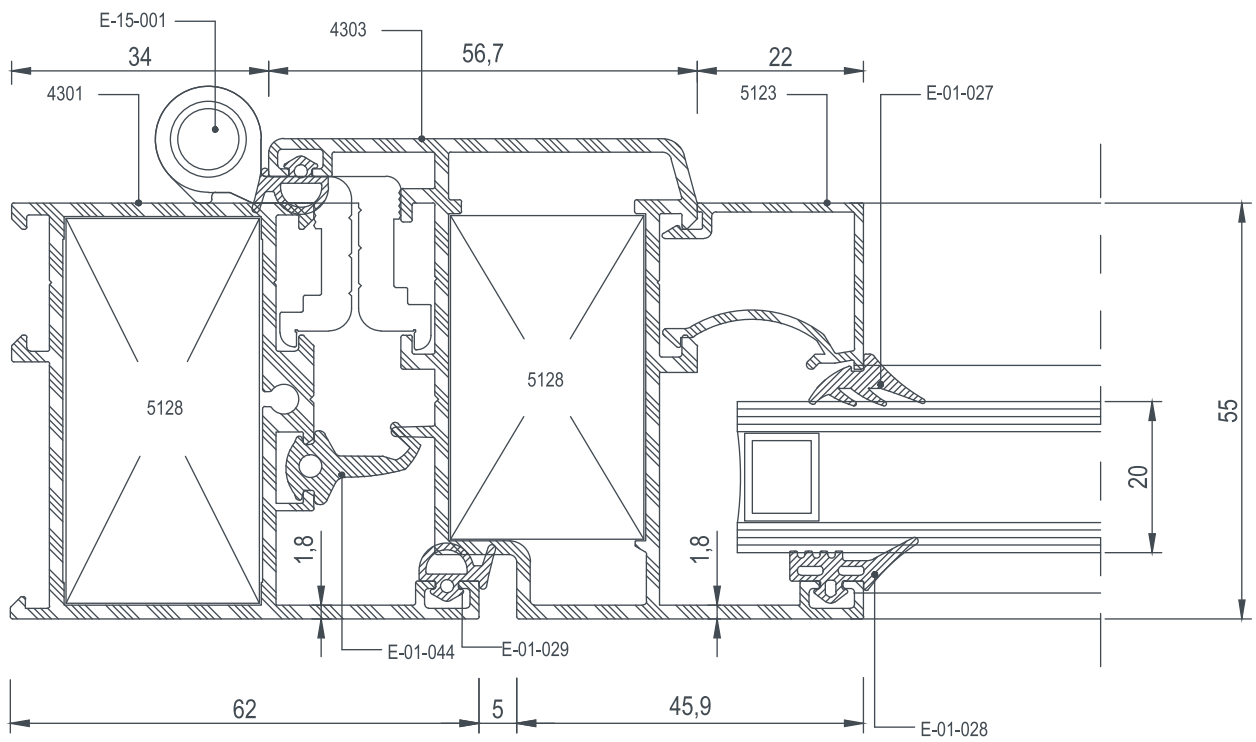



EDR 55

DETAYLAR / DETAILS

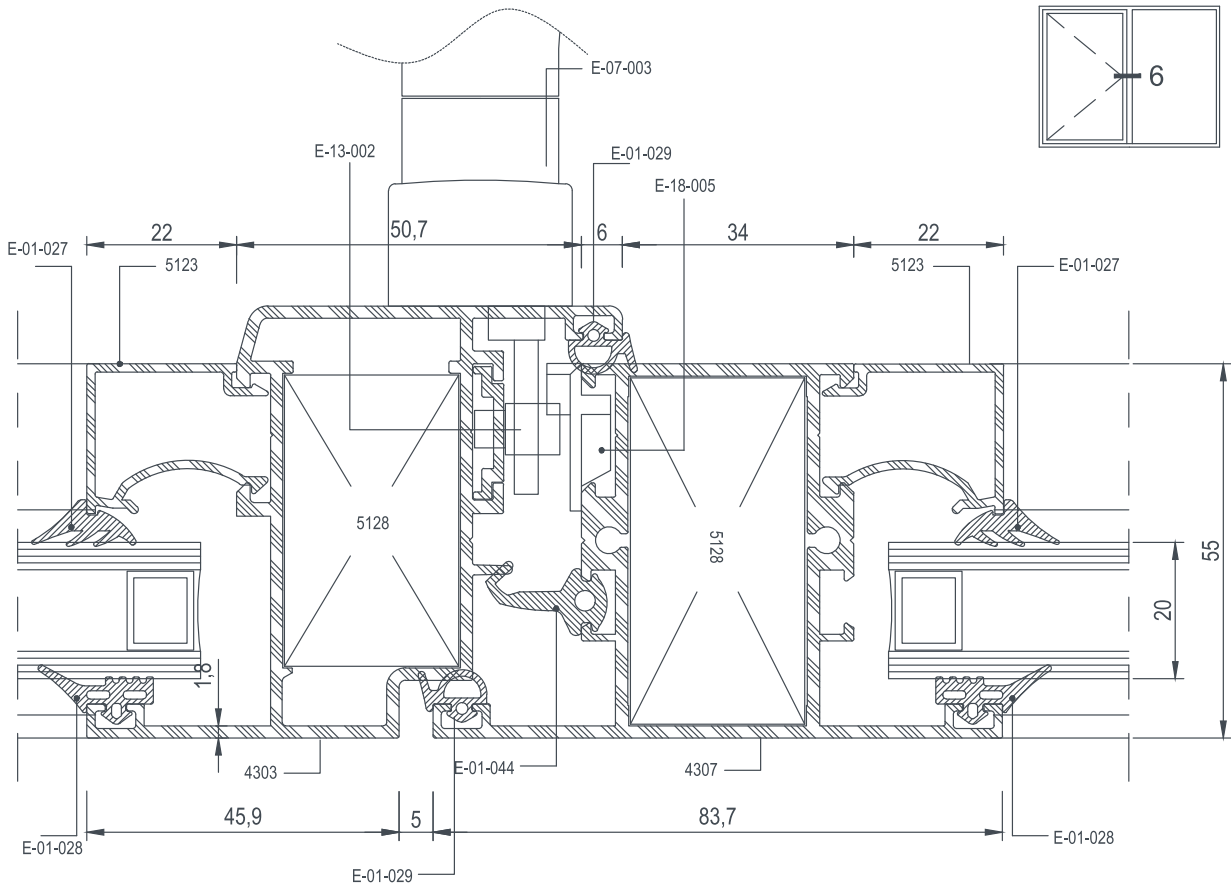
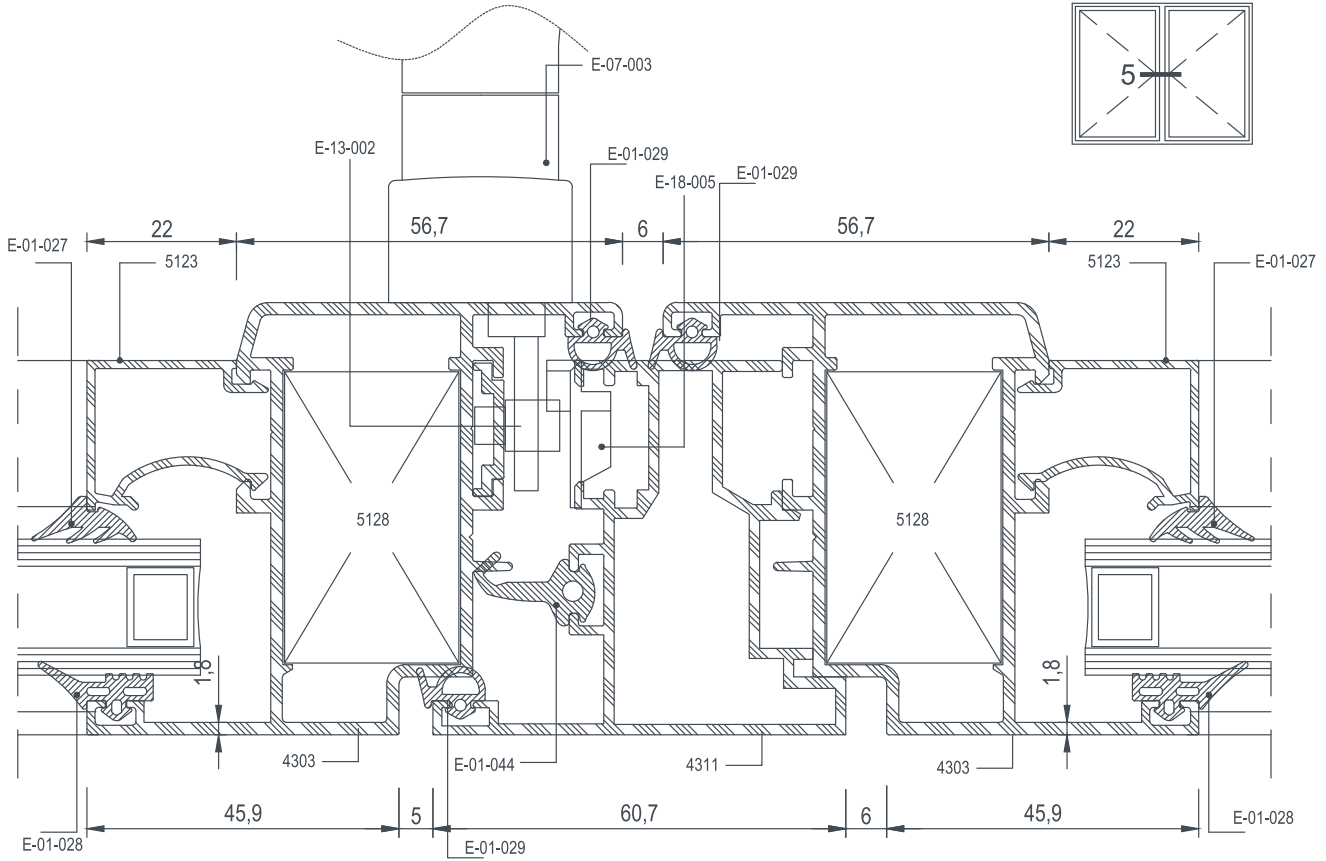

SCALE BY: 1/10



EDR 55

DETAYLAR / DETAILS

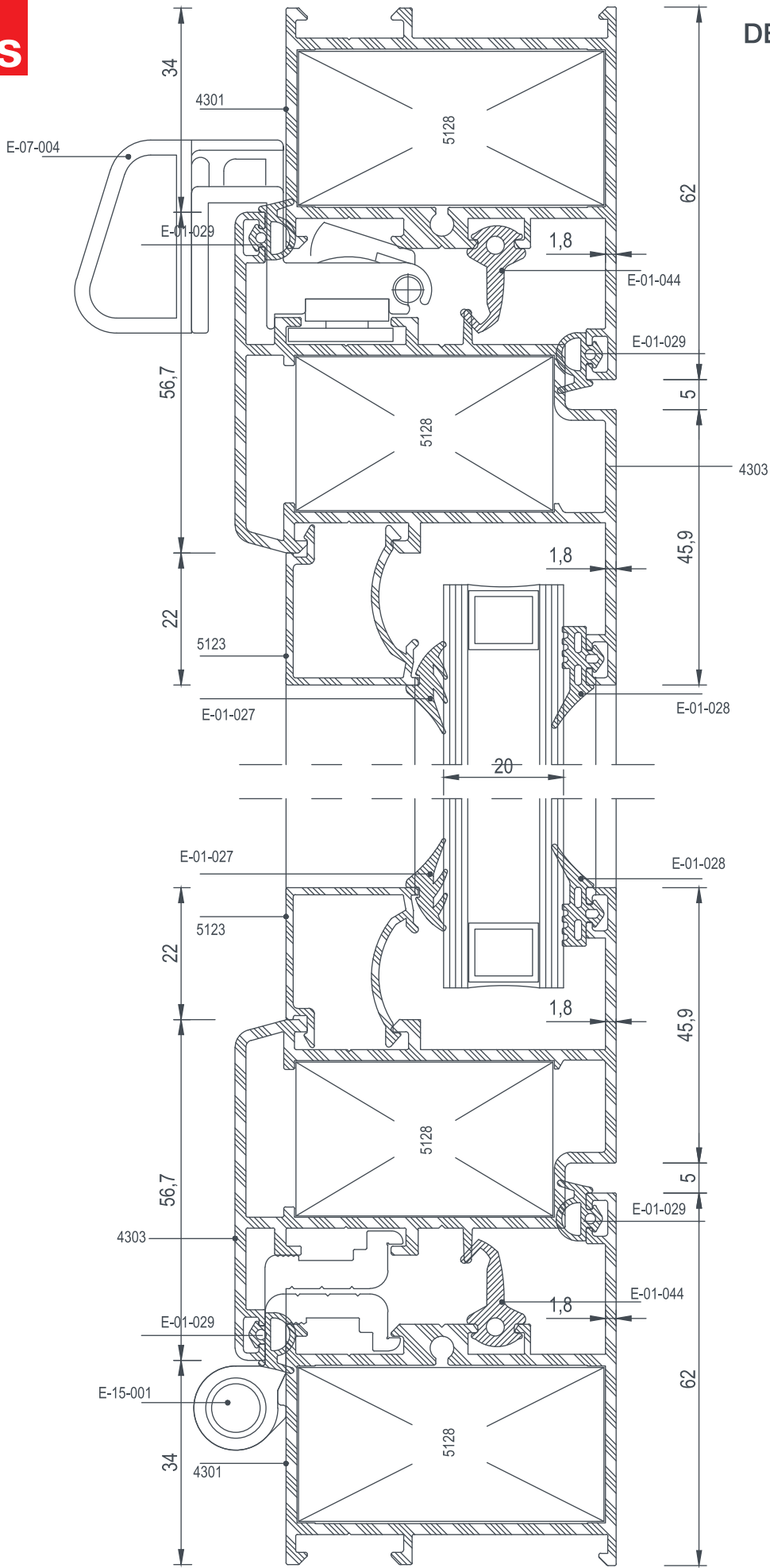

262

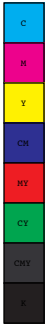



EDR 55

DETAYLAR / DETAILS

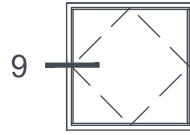
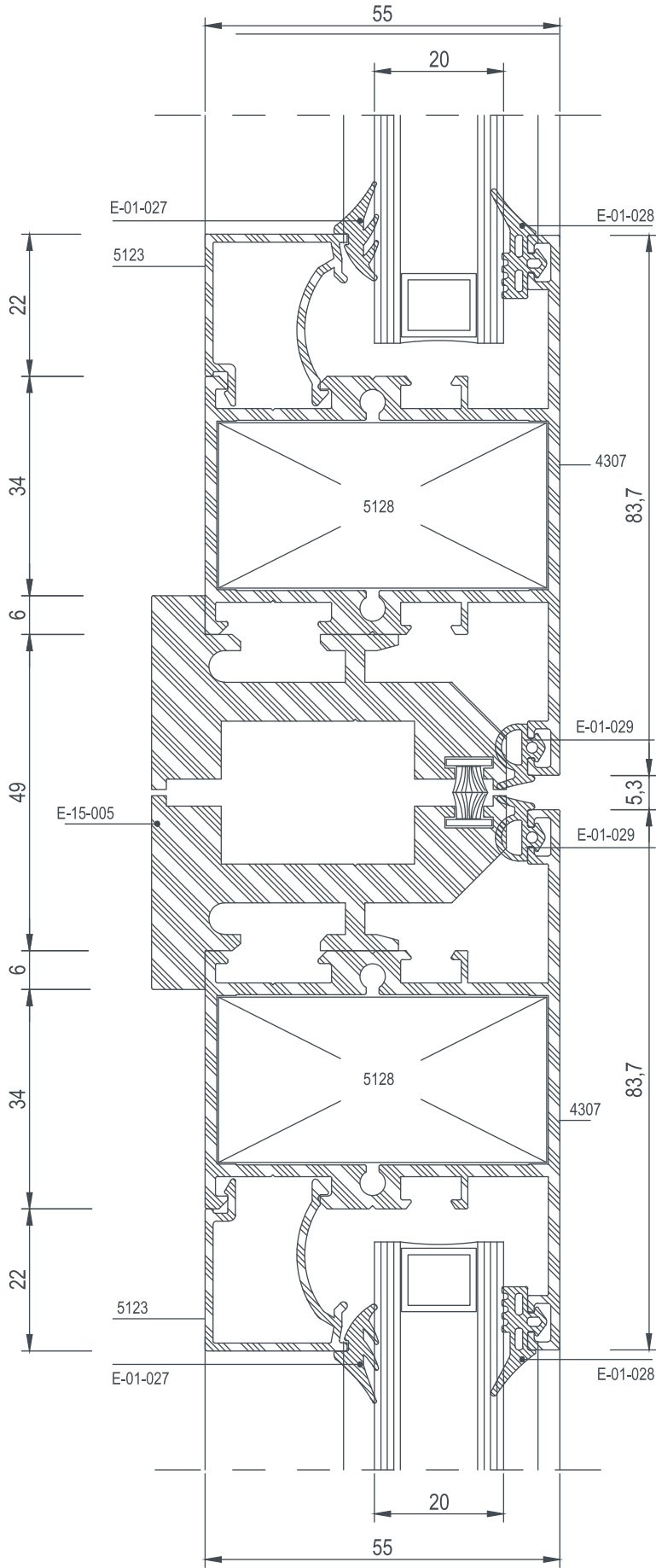



EDR 55

DETAYLAR / DETAILS

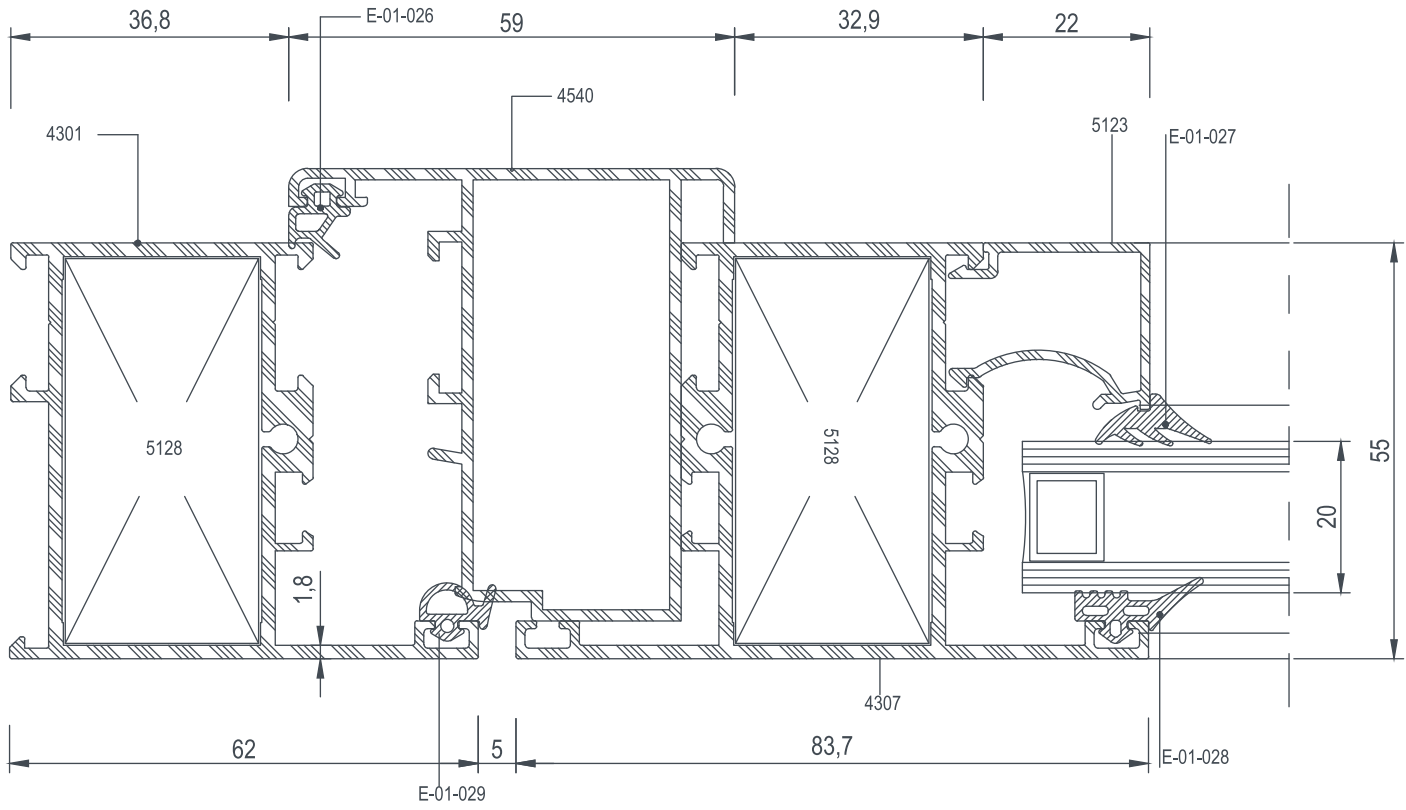
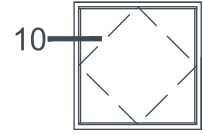



EDR 55

DETAYLAR / DETAILS

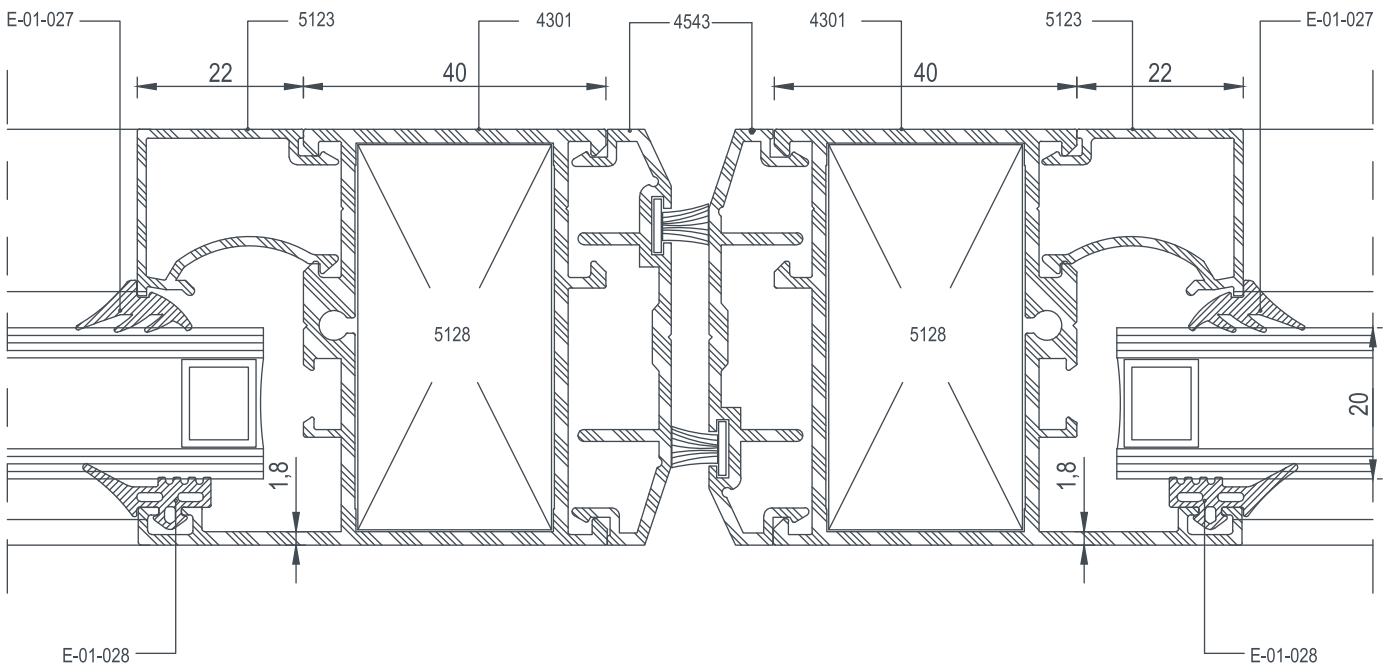
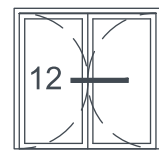
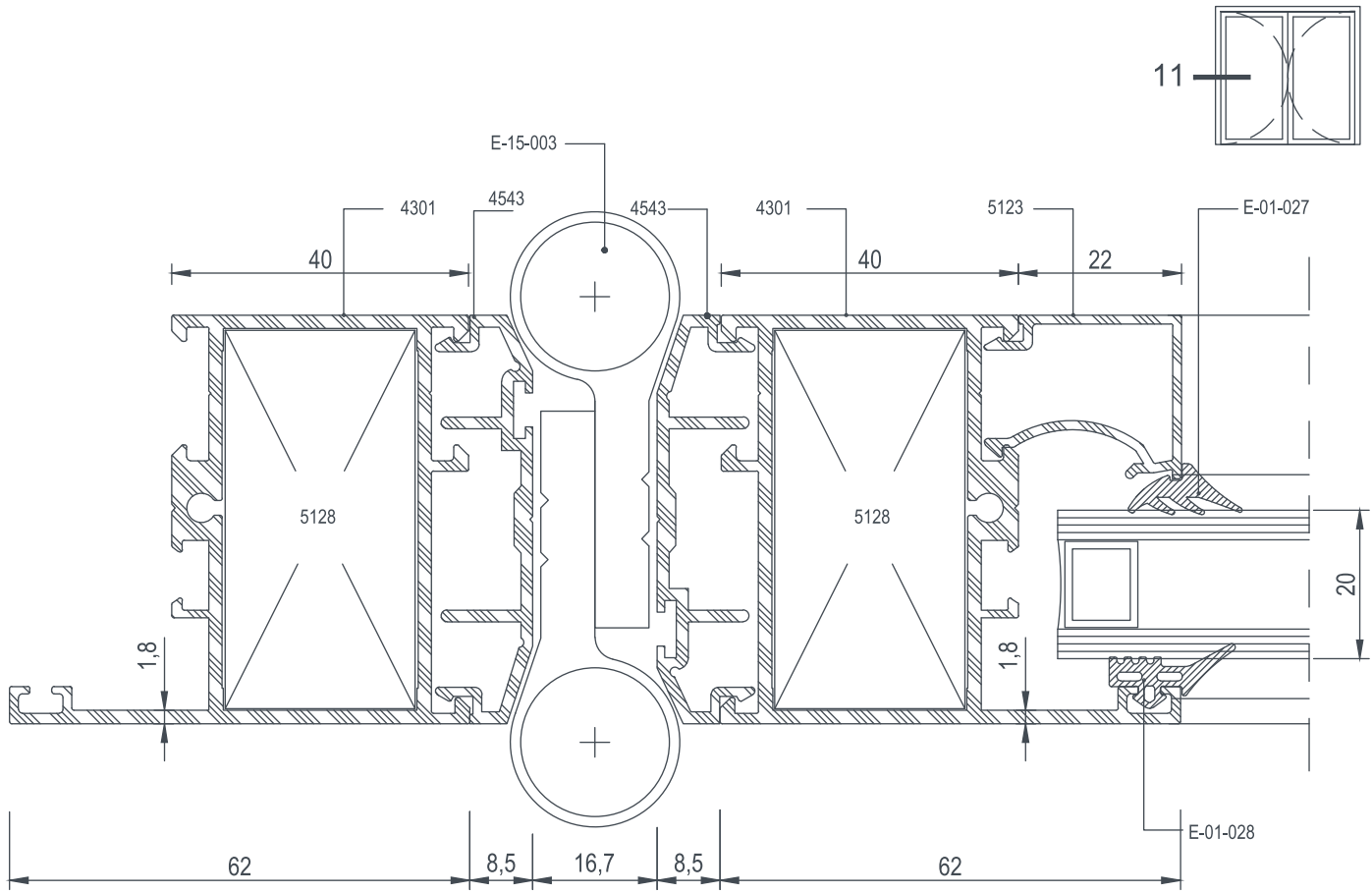



EDR 55

DETAYLAR / DETAILS

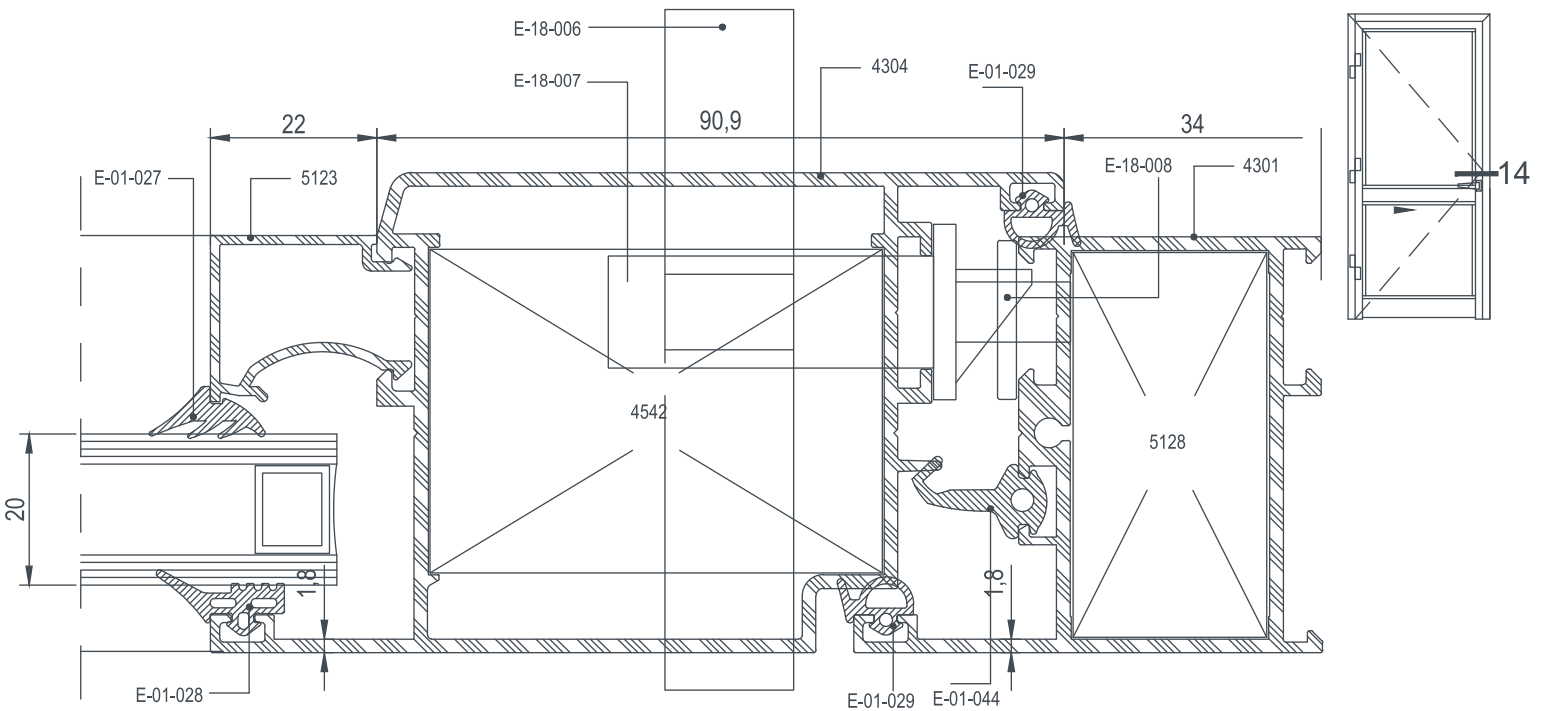
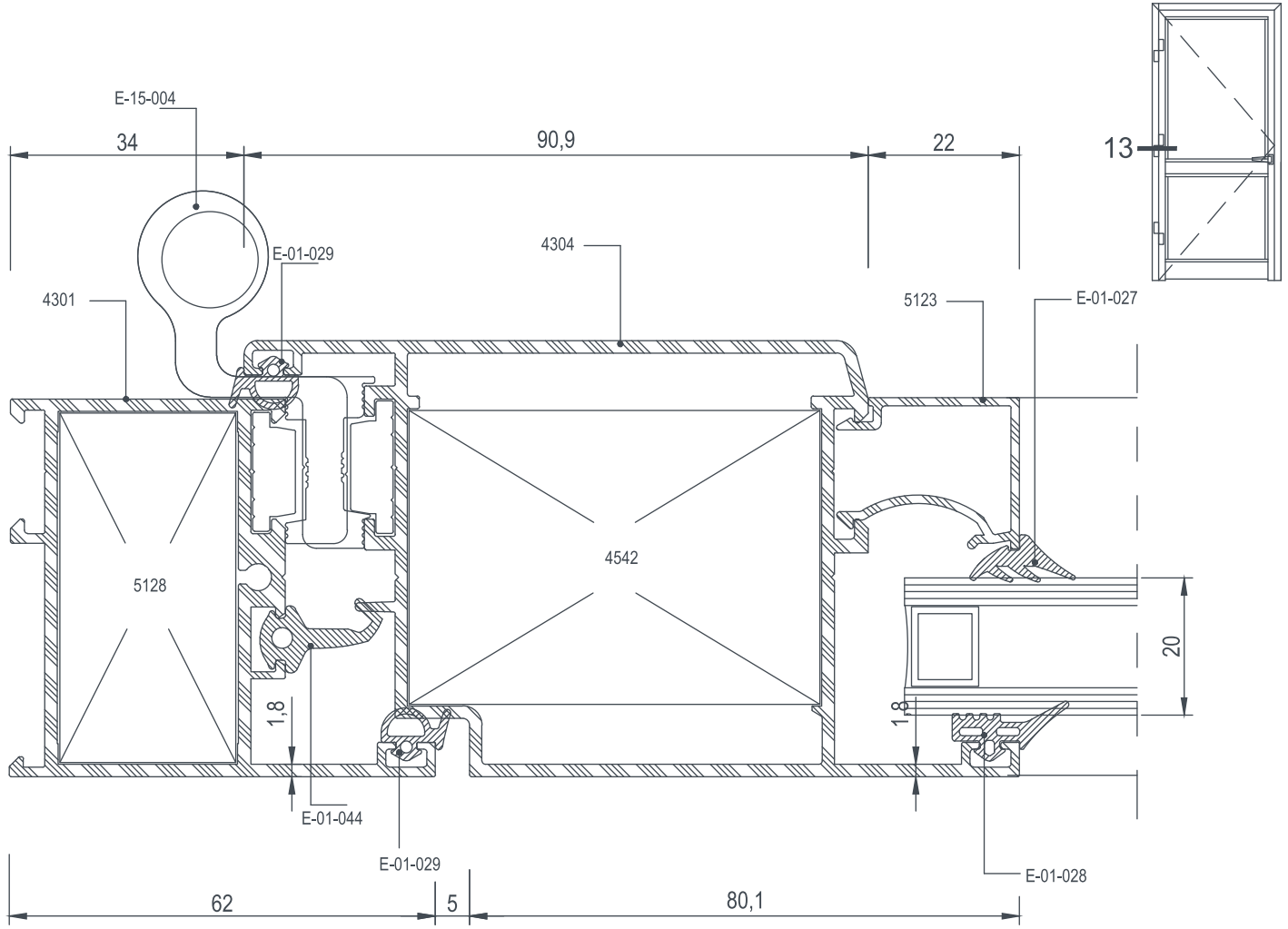



EDR 55

DETAYLAR / DETAILS

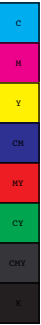
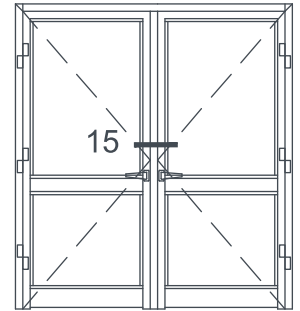
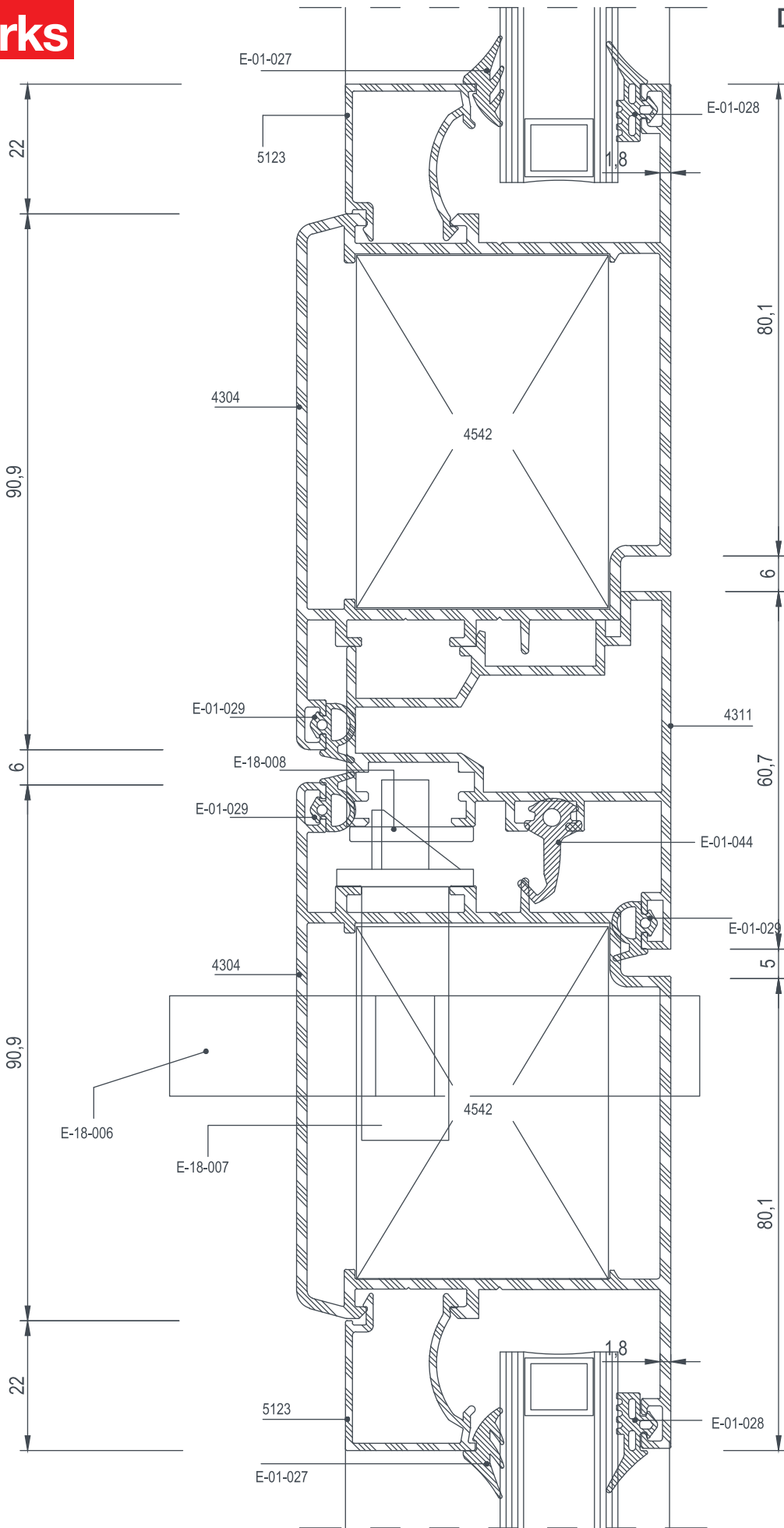



EDR 55

DETAYLAR / DETAILS

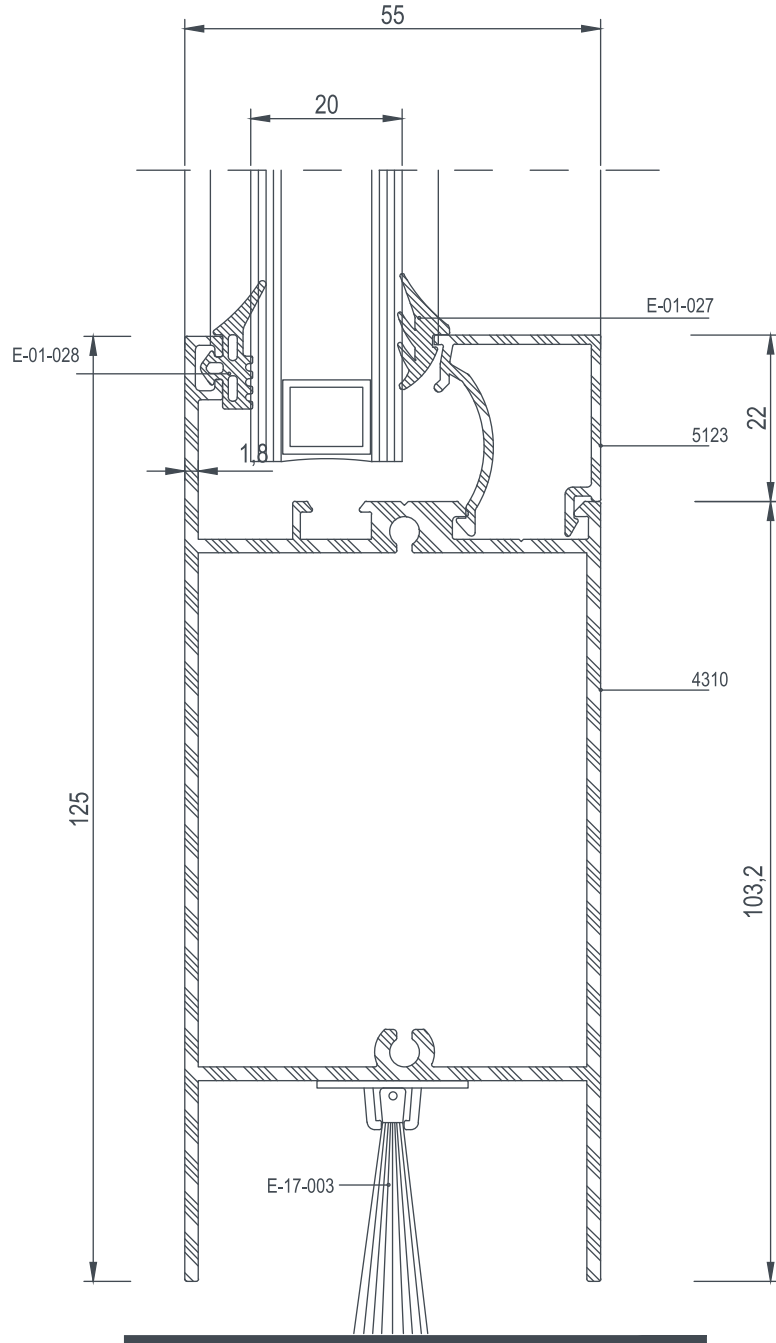



EDR 55

PROFILLER / PROFILES

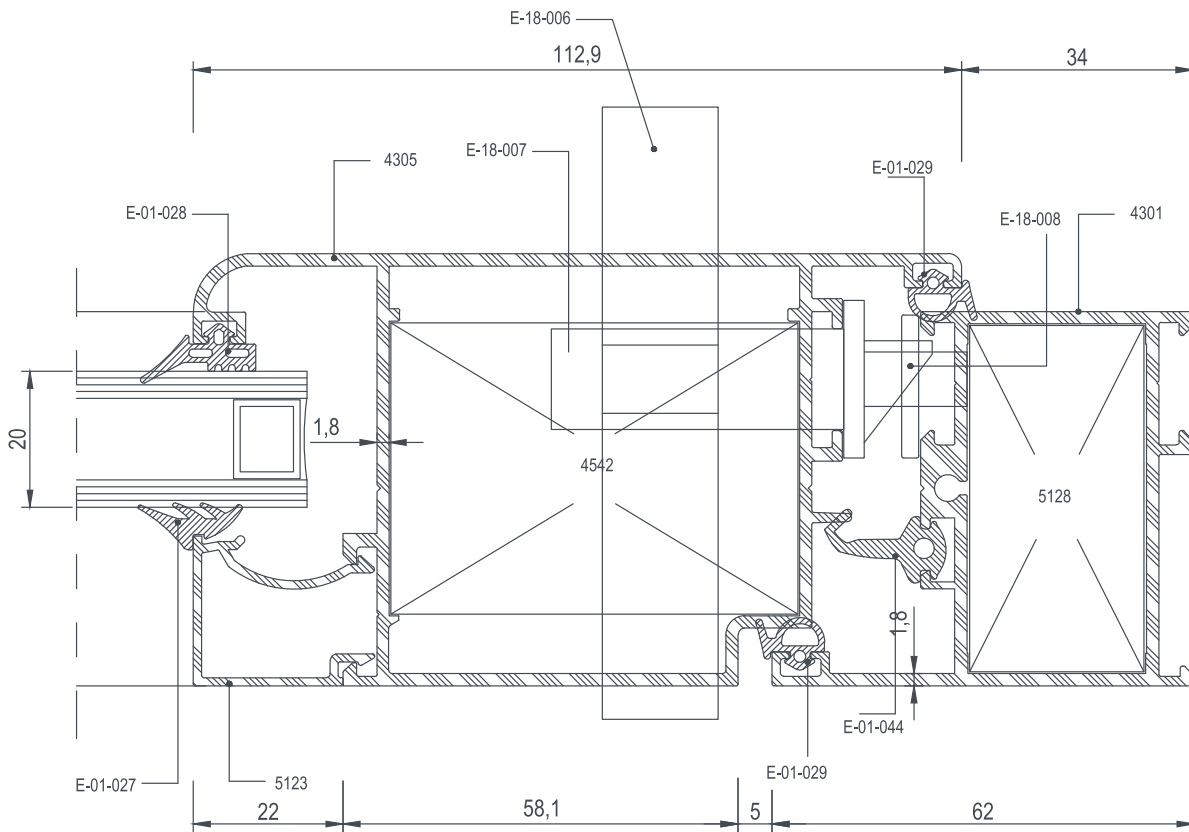
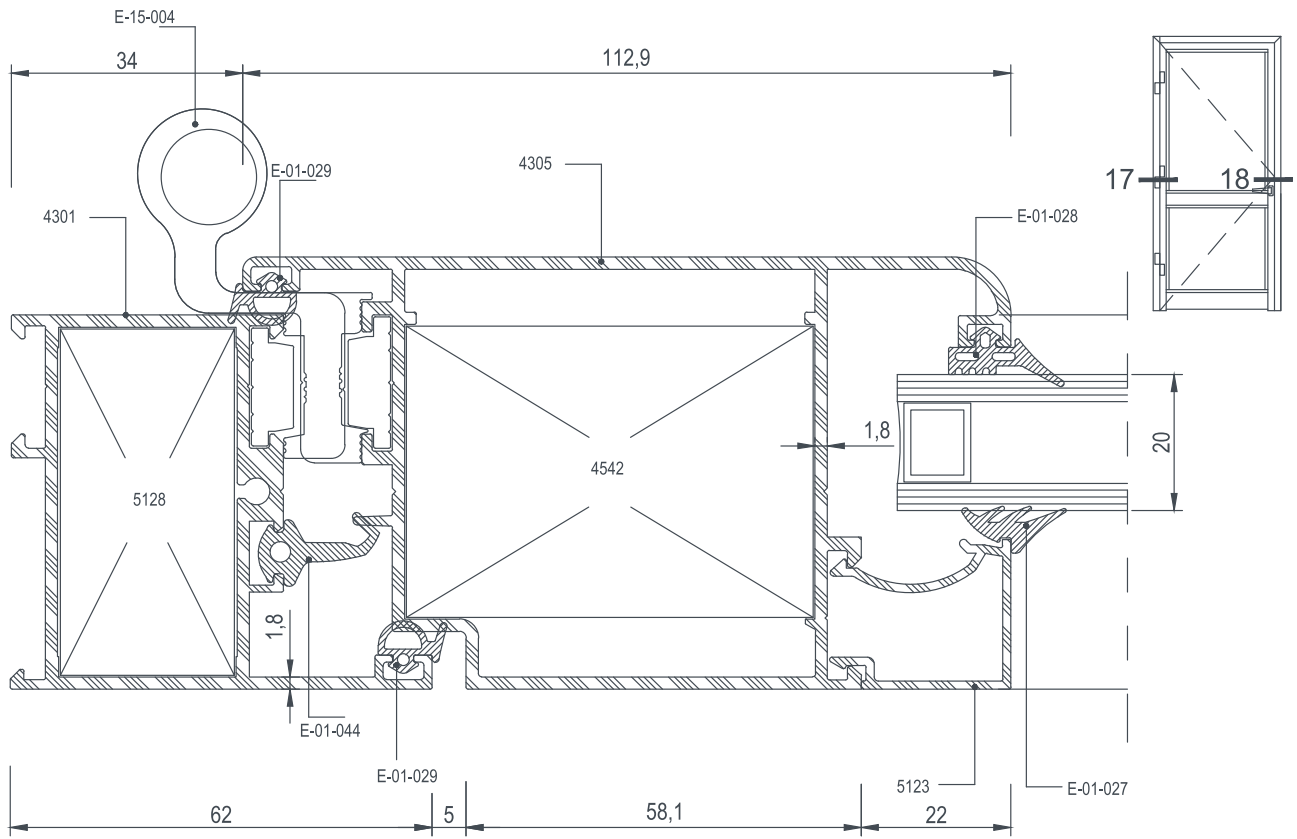



EDR 55

PROFILLER / PROFILES

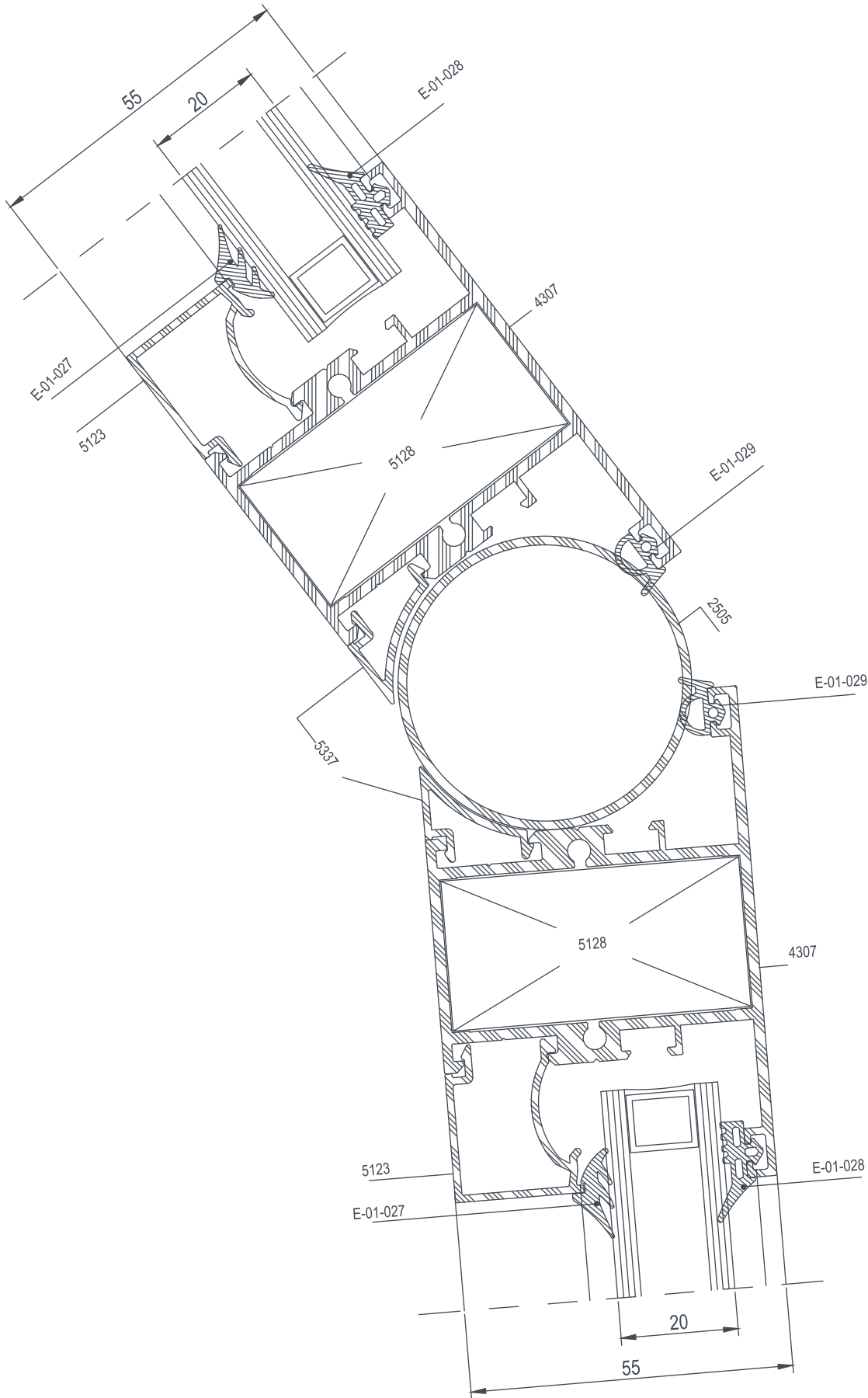

270





clarks

EDR 55









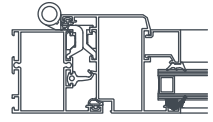
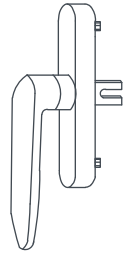
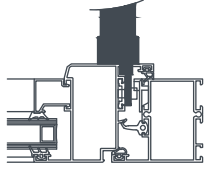

AKSESUARLAR
ACCESSORIES

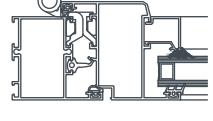

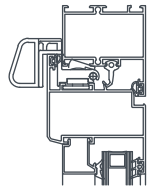

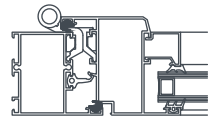
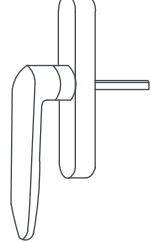
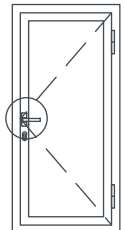
EDR 55

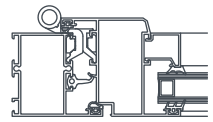
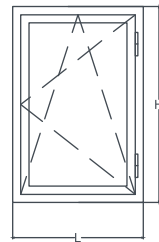
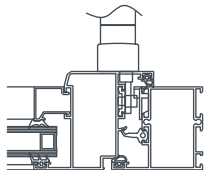

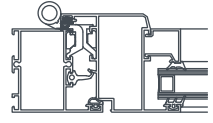
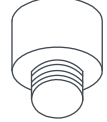
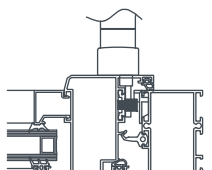



AKSESUARLAR / ACCESSORIES

	<p>E-01-028</p> <p>Dış cam fitili outside gasket</p> <p>60 gr/mt</p>			<p>E-07-003</p> <p>İspanyolet Kol Window handle</p>	
	<p>E-01-027</p> <p>İç cam fitili inside gasket</p> <p>54 gr/mt</p>			<p>E-07-004</p> <p>Vasistal Mandal Vasistas Spring</p>	
	<p>E-01-029</p> <p>Dış Bini Fitili Acoustical Gasket</p> <p>40 gr/mt</p>			<p>E-07-005</p> <p>Kapı Kolu Door Handle</p>	
	<p>E-01-044</p> <p>Tozluk Fitili Central gasket</p> <p>113 gr/mt</p>			<p>E-07-006</p> <p>Çift Açılım Mekanizması Tilt and Turn Mechanism</p> <p>L: 570~1000 mm H: 400~1200 mm</p>	
	<p>E-01-026</p> <p>İç Bini Fitili Acoustical Gasket</p> <p>39 gr/mt</p>			<p>E-13-002</p> <p>Tij Pimi Lock Pin</p>	

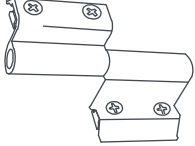
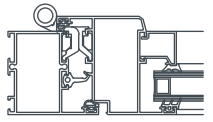
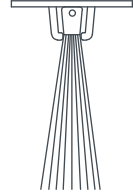
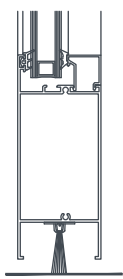
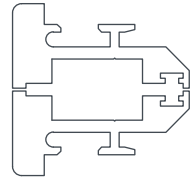
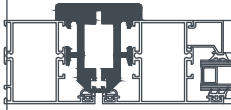

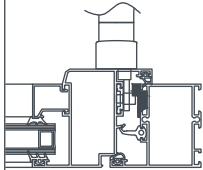
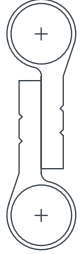
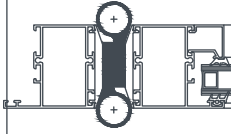
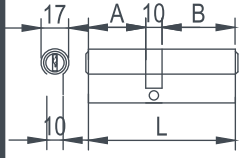
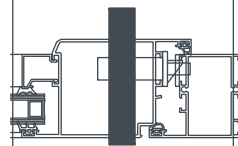
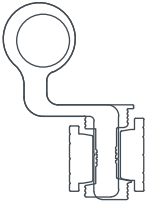
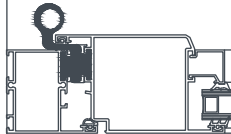
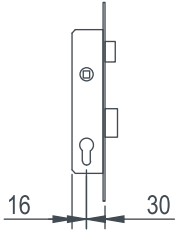
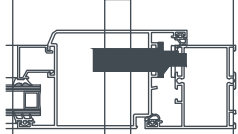
EDR 55

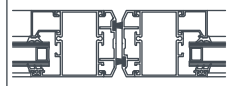

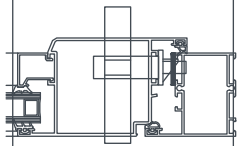
AKSESUARLAR / ACCESSORIES

	E-15-001 Pencere Menteşesi Window Hinge			E-17-003 Kapı Altı Fırçası Brush 1 Mt							
	E-15-002 Pivot Menteşe Pivot Hinge			E-18-005 Ayarlı Pim Karşılığı Lock Plate							
	E-15-003 Çarpma Kapı Menteşesi Swinge Door Hinge		 <table border="1" data-bbox="934 1384 1076 1444"> <thead> <tr> <th>A</th> <th>B</th> <th>L</th> </tr> </thead> <tbody> <tr> <td>35</td> <td>45</td> <td>90</td> </tr> </tbody> </table>	A	B	L	35	45	90	E-18-006 Barel Cylinder	
A	B	L									
35	45	90									
	E-15-004 Kapı Menteşesi Door Hinge			E-18-007 Dilli Kilit Mortise Lock							
	E-17-002 Kıl Fitol Brush			E-18-008 Dilli Kilit Karşılığı Forend							

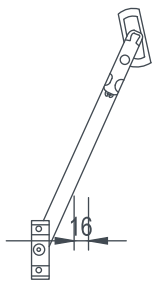
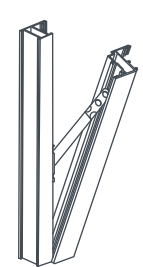
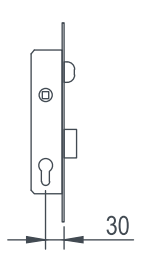
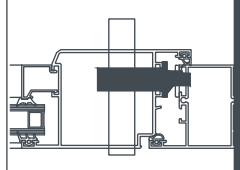

EDR 55

AKSESUARLAR / ACCESSORIES

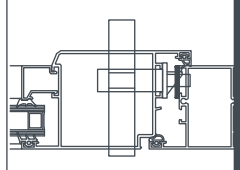
	<p>E-23-002 Vasistas Makas Vasistas Accessory</p>				
	<p>E-18-007-1 Makaralı Kilit Roller Lock</p>				
	<p>E-18-008-1 Makaralı Kilit Karşılığı Roller Forend</p>				



clarks

SERTIFIKALAR



clarks

SERTİFİKALAR
CERTIFICATES

Markanın Tanımı Description of the Mark
TSE veya/ve TSE veya/ve T S W

BELGE NUMARASI REFERENCE NUMBER OF LICENCE	028217-TSE-01/01
BELGENİN İLK VERİLİŞ TARİHİ DATE OF FIRST ISSUE OF LICENCE	27.06.2013
BELGENİN SON GEÇERLİLİK TARİHİ LICENCE VALID UNTIL	27.06.2019
BELGE SAHİBİ KURULUŞUN ADI NAME OF THE LICENCE HOLDER	ENDER PVC VE ALÜMİNYUM YAPI ELEMANLARI SAN. VE TİC. A.Ş.
BELGE SAHİBİ KURULUŞUN ADRESİ ADDRESS OF THE LICENCE HOLDER	2. ORGANİZE SAN. BÖLGESİ TEDAŞ YANI BAŞPINAR/GAZİANTEP GAZİANTEP/TÜRKİYE
ÜRETİM YERİ ADI NAME OF THE MANUFACTURING PLACE	ENDER PVC VE ALÜMİNYUM YAPI ELEMANLARI SAN.VE TİC. A.Ş.
ÜRETİM YERİ ADRESİ ADDRESS OF THE MANUFACTURING PLACE	4. ORGANİZE SANAYİ BÖLGESİ 83422 NOLU CADDE NO:3 ŞEHİTKAMİL/ GAZİANTEP / TÜRKİYE
İPTAL EDİLEN BELGE NUMARASI (Varsa) INDICATION OF SUPERSEDED LICENCE (if any)	14.0.30.4.27.00/TSE-65240
TESCİLLİ TİCARİ MARKASI REGISTERED TRADE MARK	ENDER ALÜMİNYUM
İLGİLİ TÜRK STANDARDI RELATED TURKISH STANDARD	TS EN 12020-1 / Alüminyum ve alüminyum alaşımları - EN AW- 6060 ve EN AW- 6063 alaşımlarından ekstrüzyon ile imal edilmiş hassas profiller - Bölüm 1: Teknik muayene ve teslim şartları / 02.03.2010

BELGE KAPSAMI
SCOPE OF LICENCE

ALÜMİNYUM VE ALÜMİNYUM ALAŞIMLARI
EN AW -6060 VE EN AW- 6063 ALAŞIMLARINDAN EKSTRÜZYON İLE İMAL EDİLMİŞ HASSAS PROFİLLER-
BÖLÜM-1 TEKNİK MUAYENE VE TESLİM ŞARTLARI (ISIL BARIYERSİZ PROFİLLER)
ALÜMİNYUM VE ALÜMİNYUM ALAŞIMLARINDAN
EKSTRÜZYON İLE İMAL EDİLMİŞ HASSAS PROFİLLER-EN AW -6060 VE EN AW- 6063 ALAŞIMLI ALÜMİNYUM
MALZEMEDEN ISIL BARIYERLİ VE ISIL BARIYERSİZ PROFİLLER

e-İmzalı/e-signed

12.06.2018

Belgelendirme Merkezi Başkanı Adına
MEHMET TUNÇER

GAZİANTEP BELGELENDİRME MÜDÜR V.

*Bu belge, belgelendirilen ürünün, üretim yerinin Enstitümüzün belirlediği şartları karşıladığını da gösterir.
*Bu belge hiç bir suretle tahrif edilemez. Kısmen veya okunmasını zorlaştıracak şekilde çoğaltılamaz, kızırtı ve silinti yapılamaz.
*TSE GAZİANTEP BELGELENDİRME MÜDÜRLÜĞÜ * Adres: 2.Organize Sanayi Bölgesi Hacı Sani Konukoğlu Bulvarı No 9 Başpınar 27120 Şehitkamil GAZİANTEP * Tel: 0 342 337 95 03 (Pbx) * Faks: 0 342 337 95 08
*TSE BELGELENDİRME MERKEZİ BAŞKANLIĞI, Adres: Necatibey Cad. No:112 06100 Bakanlıklar/ANKARA – Tel: 0 312 416 64 81 / 416 64 27, Faks: 0 312 416 66 17
e-posta : bmb@tse.org.tr , web : www.tse.org.tr

<https://evrakkontrol.tse.org.tr/BelgeDogrulama.aspx?p=cbhf2pe> adresinden belgenin doğruluğunu ve geçerliliğini sorgulayınız.



1 / 1

clarks

SERTİFİKALAR

CERTIFICATES

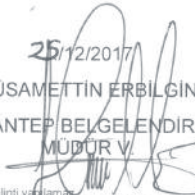
 TÜRK STANDARDLARI ENSTİTÜSÜ TÜRK STANDARDLARINA UYGUNLUK BELGESİ TURKISH STANDARDS INSTITUTION CERTIFICATE OF CONFORMITY TO TURKISH STANDARDS	
Markanın Tanımı Description of the Mark TSE veya/or  veya/or T S E	
BELGE NUMARASI REFERENCE NUMBER OF LICENCE	028217-TSE-03/01
BELGENİN İLK VERİLİŞ TARİHİ DATE OF FIRST ISSUE OF LICENCE	05.12.2014
BELGENİN SON GEÇERLİLİK TARİHİ LICENCE VALID UNTIL	05.12.2018
BELGE SAHİBİ KURULUŞUN ADI NAME OF THE LICENCE HOLDER	ENDER PVC VE ALÜMİNYUM YAPI ELEMANLARI SAN. VE TIC. A.Ş.
BELGE SAHİBİ KURULUŞUN ADRESİ ADDRESS OF THE LICENCE HOLDER	2. ORGANİZE SAN. BÖLGESİ TEDAŞ YANI BAŞPINAR/GAZİANTEP / TÜRKİYE
ÜRETİM YERİ ADI NAME OF THE MANUFACTURING PLACE	ENDER PVC VE ALÜMİNYUM YAPI ELEMANLARI SAN. VE TIC. A.Ş.
ÜRETİM YERİ ADRESİ ADDRESS OF THE MANUFACTURING PLACE	4. ORGANİZE SANAYİ BÖLGESİ 83422 NOLU CD.NO:3 ŞEHİTKAMİL GAZİANTEP / TÜRKİYE
İPTAL EDİLEN BELGE NUMARASI (Varsa) INDICATION OF SUPERSEDED LICENCE (if any)	14.0.30.4.27.00/TSE-65307
TESCİLLİ TİCARİ MARKASI REGISTERED TRADE MARK	ENDER ALÜMİNYUM
İLGİLİ TÜRK STANDARDI RELATED TURKISH STANDARD	TS 4922 / Metalik Malzemelerin Yüzey İşlemi- Alüminyum ve Biçimlenebilir Alüminyum Alaşımlarının Anodik Oksidasyonu (Eloksal), Teknik Özellikler / 27.10.1986
BELGE KAPSAMI SCOPE OF LICENCE	<ul style="list-style-type: none"> -Alüminyum ve biçimlenebilir alüminyum alaşımlarının anodik oksidasyonu (eloksal) – Normal kalite. Fırçalama işlemi tatbik edilmiş (E2), Eloksal kaplama kalınlığı: 10 µm -Alüminyum ve biçimlenebilir alüminyum alaşımlarının anodik oksidasyonu (eloksal) – Normal kalite. Parlatma Ön işlemi tatbik edilmiş (E3), Eloksal kaplama kalınlığı: 10 µm -Alüminyum ve biçimlenebilir alüminyum alaşımlarının anodik oksidasyonu (eloksal) – Normal kalite. Kimyasal matlaştırma Ön işlemi tatbik edilmiş (E6), Eloksal kaplama kalınlığı: 10 µm -Alüminyum ve biçimlenebilir alüminyum alaşımlarının anodik oksidasyonu (eloksal) – Normal kalite. Fırçalama işlemi tatbik edilmiş (E2), Eloksal kaplama kalınlığı: 20 µm -Alüminyum ve biçimlenebilir alüminyum alaşımlarının anodik oksidasyonu (eloksal) – Normal kalite. Parlatma Ön işlemi tatbik edilmiş (E3), Eloksal kaplama kalınlığı: 20 µm -Alüminyum ve biçimlenebilir alüminyum alaşımlarının anodik oksidasyonu (eloksal) – Normal kalite. Kimyasal matlaştırma Ön işlemi tatbik edilmiş (E6), Eloksal kaplama kalınlığı: 20 µm
 25/12/2017 HÜSAMETTİN ERBİLGİN GAZİANTEP BELGELENDİRME MÜDÜR V.	
<small>*Bu belge belgelendirilen ürünün üretim yerinin Enstitümüzün belirlediği şartları karşıladığını da gösterir. *Bu belge hiç bir surette tahrif edilmez, kışmen veya okunmasını zorlaştıracak şekilde çoğaltılamaz, kızırtı ve silinti yapılamaz. *TSE GAZİANTEP BELGELENDİRME MÜDÜRLÜĞÜ * Adres: 2.Organize Sanayi Bölgesi Hacı Sami Konukoğlu Bulvarı No:9 Başpınar 27120 Şehitkamil GAZİANTEP * Tel: 0 342 337 95 00 / Faks: 0 342 337 95 06 *TSE BELGELENDİRME MERKEZİ BAŞKANLIĞI; Adres: Necatibey Cad. No:112 06100 Bakanlıklar/ANKARA – Tel: 0 312 416 64 81 / 416 64 27. Faks: 0 312 416 66 17 *E-posta: tse@tse.org.tr, web: www.tse.org.tr</small>	
https://www.kontroltse.org.tr/BelgeDogrulama.aspx?p=sgnqxjm adresinden belgenin doğruluğunu ve geçerliliğini sorgulayınız.	
	
1 / 1	

clarks

SERTİFİKALAR
CERTIFICATES

Markanın Tanımı Description of the Mark
TSE veya/ör TSE veya/ör T S W

BELGE NUMARASI REFERENCE NUMBER OF LICENCE	028217-TSE-02/02
BELGENİN İLK VERİLİŞ TARİHİ DATE OF FIRST ISSUE OF LICENCE	09.02.2015
BELGENİN SON GEÇERLİLİK TARİHİ LICENCE VALID UNTIL	31.12.2018
BELGE SAHİBİ KURULUŞUN ADI NAME OF THE LICENCE HOLDER	ENDER PVC VE ALÜMİNYUM YAPI ELEMANLARI SAN. VE TİC. A.Ş.
BELGE SAHİBİ KURULUŞUN ADRESİ ADDRESS OF THE LICENCE HOLDER	2. ORGANİZE SAN. BÖLGESİ TEDAŞ YANI BAŞPINAR/GAZİANTEP GAZİANTEP/TÜRKİYE
ÜRETİM YERİ ADI NAME OF THE MANUFACTURING PLACE	ENDER PVC VE ALÜMİNYUM YAPI ELEMANLARI SAN. VE TİC. A.Ş.
ÜRETİM YERİ ADRESİ ADDRESS OF THE MANUFACTURING PLACE	4.ORGANİZE SANAYİ BÖLGESİ 83422 NOLU CD.NO:3 ŞEHİTKAMİL GAZİANTEP / TÜRKİYE
İPTAL EDİLEN BELGE NUMARASI (Varsa) INDICATION OF SUPERSEDED LICENCE (if any)	028217-TSE-02/01
TESCİLLİ TİCARİ MARKASI REGISTERED TRADE MARK	ENDER ALÜMİNYUM
İLGİLİ TÜRK STANDARDI RELATED TURKISH STANDARD	TS EN 755-1 / Alüminyum ve alüminyum alaşımları – Ekstrüzyonla imal edilmiş tellik çubuk/çubuk, boru ve profiller – Bölüm 1: Muayene ve teslim için teknik şartlar / 09.03.2010
BELGE KAPSAMI SCOPE OF LICENCE	

ALÜMİNYUM VE ALÜMİNYUM ALAŞIMLARI – EKSTRÜZYONLA İMAL EDİLMİŞ TELLİK ÇUBUK/ÇUBUK, BORU
VE PROFİLLER – EN AW 6060 ALAŞIMINDAN İMAL EDİLMİŞ, TELLİK ÇUBUK VE PROFİL

ALÜMİNYUM VE ALÜMİNYUM ALAŞIMLARI – EKSTRÜZYONLA İMAL EDİLMİŞ TELLİK ÇUBUK/ÇUBUK, BORU
VE PROFİLLER – EN AW 6063 ALAŞIMINDAN İMAL EDİLMİŞ, TELLİK ÇUBUK VE PROFİL

e-İmzalı/e-signed

12.06.2018

Belgelendirme Merkezi Başkanı Adına
MEHMET TUNÇER

GAZİANTEP BELGELENDİRME MÜDÜR V.

*Bu belge, belgelendirilen ürünün, üretim yerinin Enstitümüzün belirlediği şartları karşıladığını da gösterir.
*Bu belge hiç bir suretle tahrif edilemez, kısmen veya okunmasını zorlaştıracak şekilde çoğaltılamaz, kaza ve silinti yapılamaz.
*TSE GAZİANTEP BELGELENDİRME MÜDÜRLÜĞÜ * Adres: 2.Organize Sanayi Bölgesi Hacı Sani Konukoğlu Bulvarı No:9 Başpınar 27120 Şehitkamil GAZİANTEP * Tel: 0 342 337 95
03 (Pbx)* Faks: 0 342 337 95 08
*TSE BELGELENDİRME MERKEZİ BAŞKANLIĞI; Adres: Necatibey Cad. No:112 06100 Bakanlıklar/ANKARA – Tel: 0 312 416 64 81 / 416 64 27, Faks: 0 312 416 66 17
e-posta : bmb@tse.org.tr , web : www.tse.org.tr

<https://evrakkontrol.tse.org.tr/BelgeDogrulama.aspx?p=7mg0ttqn> adresinden belgenin doğruluğunu ve geçerliliğini sorgulayınız.



1 / 1



SERTİFİKALAR

CERTIFICATES

Authorization to use the quality sign



This is to certify that

Ender Pvc ve Alüminyum Yapı Elemanları Sanayi ve Ticaret A.S.

4. OSB 83422 Nolu Cadde No: 3
TR – 27500 Baspınar-Gaziantep

Licence number: 1643

is authorized to use the quality sign which is shown above, according to the regulations for the use of the quality label for ARCHITECTURAL ANODIZING as described in the current edition of the Specifications for the QUALANOD quality label for sulfuric acid-based anodizing of aluminium (Edition 01.01.2017). Architectural anodizing is one of the four types of anodizing covered by the Specifications.

Date of issue of the licence: 06.01.2016
Period of validity of the licence: until 31.12.2018

Zürich, 23 November 2017

QUALANOD



José Arenas
President

CERTIFICATION BODY



Josef Schoppig
AC-Fiduciaire SA



Mailing address:
QUALANOD, P.O. Box 1507, CH-8027 Zurich

Domicile:
QUALANOD
c/o AC-Fiduciaire SA (certification body)
Tödstrasse 42, CH-8002 Zurich

Phone: +41 (0)43 305 09 70
E-Mail: j.schoppig@actreu.ch

Fax: +41 (0)43 305 09 98
Website: www.qualanod.net



SERTİFİKALAR

CERTIFICATES

Authorization to use the quality sign



This is to certify that

**Ender Pvc ve Aluminyum Yapı Elemanları Sanayi ve Ticaret
A.S.**

4. OSB 83422 Nolu Cadde No: 3
TR – 27500 Baspınar-Gaziantep

Licence number: 1452

is authorized to use the quality sign which is shown above according to the REGULATIONS FOR THE USE OF THE QUALICOAT QUALITY SIGN FOR PAINT, LACQUER AND POWDER COATINGS ON ALUMINIUM FOR ARCHITECTURAL APPLICATIONS.

Date of issue of the licence: 30.12.1899
Period of validity of the licence: until 31.12.2018

Zurich, 19 December 2017

QUALICOAT

CERTIFICATION BODY

M.C. Panam

JS

Mohammed C. Panam
President

Josef Schoppig
AC-Fiduciaire SA



Mailing address:
QUALICOAT, P.O. Box 1507, CH-8027 Zurich
Domicile:
QUALICOAT c/o AC-Fiduciaire SA, Tödistrasse 42, CH-8002 Zurich

Phone: +41 (0)43 305 09 70/79
Fax: +41 (0)43 305 09 98
E-mail: info@qualicoat.net
Internet: www.qualicoat.net

clarks

SERTİFİKALAR

CERTIFICATES



SERTİFİKA

81194

Bu sertifika aşağıda adı geçen kuruluşa UDEM Uluslararası Belgelendirme Denetim Eğitim Merkezi San. ve Tic. A.Ş. tarafından verilmiştir.

Ender PVC ve Alüminyum Yapı Elemanları Sanayi ve Ticaret Anonim Şirketi

Merkez: 2. Organize Sanayi Bölgesi 27120 Tedaş Bitişiği Başpınar
GAZİANTEP / TÜRKİYE
Fabrika: 4. Organize Sanayi Bölgesi 83422 No'lu Cadde Şehitkamil
GAZİANTEP / TÜRKİYE

OHSAS-18001

Kapsam: Alüminyum profil imalatı

EA Kodu: 17

Belgelendirme Denetim Tarihi : 04.05.2015
Tescil Tarihi : 13.05.2015
Yeniden Basım Tarihi : 10.05.2018
Geçerlilik Tarihi : 12.05.2019



UDEM Uluslararası Belgelendirme
Denetim Eğitim Merkezi
San. ve Tic. A.Ş. Onayı



UDEM Uluslararası Belgelendirme Denetim Eğitim Merkezi Sanayi ve Ticaret Anonim Şirketi bu belge ile adı geçen kuruluşun yukarıdaki standardın şartlarına uygun bir yönetim sistemine sahip olduğunu belgeler. Sistem etkin bir şekilde sürdürüldükçe ve gözetim denetimleri zamanında yapıldığı müddetçe bu belge tescil tarihinden itibaren 3 yıl boyunca geçerlidir. Belgenin geçerliliği www.udem.com.tr İnternet sayfasından kontrol edilebilir. Bu belgenin mülkiyet hakkı UDEM Uluslararası Belgelendirme Denetim Eğitim Merkezi Sanayi ve Ticaret Anonim Şirketi'ne aittir ve istenildiğinde iade edilmelidir.

Adres: Mutlukent Mahallesi 2073 Sokak (Eski 93 Sokak) No:10 Çankaya – Ankara – TÜRKİYE
Tel: +90 312 443 03 90 (pbx) Faks: +90 312 443 03 76
E-posta: info@udemitd.com.tr Web: www.udem.com.tr

clarks

SERTİFİKALAR

CERTIFICATES



CERTIFICATE

81194

This certificate was given to the below stated company by UDEM International Certification
Audit Training Cent. Ind. Inc. Co.

Ender PVC ve Alüminyum Yapı Elemanları Sanayi ve Ticaret Anonim Şirketi

Head Office: 2.Organize Sanayi Bölgesi 27120 Tedaş Bitişiği Başpınar
GAZIANTEP / TURKEY

Factory: 4. Organize Sanayi Bölgesi 83422 No'lu Cadde Şehitkamil
GAZIANTEP / TURKEY

O H S A S - 1 8 0 0 1

Scope: Manufacturing of aluminum profile

EA Code: 17

Certification Audit Date	: 04.05.2015
Decision Date	: 13.05.2015
Reissue Date	: 10.05.2018
Expiry Date	: 12.05.2019



UDEM International Certification
Audit Training Cent. Ind. Inc. Co.



Hereby, UDEM International Certification Audit Training Cent. Ind. Inc. Co. certifies that the above stated company have the appropriate management system according to the requirements of the above standard. This certificate is valid for 3 years since the decision date as long as the system is effectively maintained and surveillance audits are carried out. The validity of the certificate can be checked through www.udem.com.tr. The certificate is the property of UDEM International Certification Audit Training Cent. Ind. Inc. Co. and shall be returned if requested.

Address: Mutlukent Mahallesi 2073 Sokak (Eski 93 Sokak) No:10 Çankaya – Ankara - TURKEY
Tel: +90 312 443 03 90 (pbx) Fax: +90 312 443 03 76
E-mail: info@udemltd.com.tr Web: www.udem.com.tr

clarks

SERTİFİKALAR

CERTIFICATES



SERTİFİKA

61236

Bu sertifika aşağıda adı geçen kuruluşa UDEM Uluslararası Belgelendirme Denetim Eğitim Merkezi San. ve Tic. A.Ş. tarafından verilmiştir.

Ender PVC ve Alüminyum Yapı Elemanları Sanayi ve Ticaret Anonim Şirketi

Merkez: 2.Organize Sanayi Bölgesi 27120 Tedaş Bitişiği Başpınar
GAZİANTEP / TÜRKİYE
Fabrika: 4. Organize Sanayi Bölgesi 83422 No'lu Cadde Şehitkamil
GAZİANTEP / TÜRKİYE

ISO 14001:2015

Kapsam: Alüminyum profil imalatı

EA Kodu: 17

Belgelendirme Denetim Tarihi : 09.05.2015
Tescil Tarihi : 13.05.2015
Yeniden Basım Tarihi : 10.05.2018
Geçerlilik Tarihi : 12.05.2019



UDEM Uluslararası Belgelendirme
Denetim Eğitim Merkezi
San. ve Tic. A.Ş. Onayı

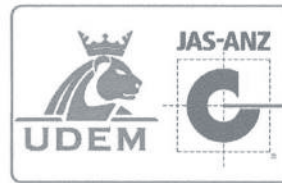

UDEM Uluslararası Belgelendirme Denetim Eğitim Merkezi Sanayi ve Ticaret Anonim Şirketi bu belge ile adı geçen kuruluşun yukarıdaki standardın şartlarına uygun bir yönetim sistemine sahip olduğunu belgeler. Sistem etkin bir şekilde sürdürüldükçe ve gözetim denetimleri zamanında yapıldığı müddetçe bu belge tescil tarihinden itibaren 3 yıl boyunca geçerlidir. Belgenin geçerliliği www.udem.com.tr www.jas-anz.org/register internet sayfasından kontrol edilebilir. Bu belgenin mülkiyet hakkı UDEM Uluslararası Belgelendirme Denetim Eğitim Merkezi Sanayi ve Ticaret Anonim Şirketi'ne aittir ve istenildiğinde iade edilmelidir.

Adres: Mutlukent Mahallesi 2073 Sokak (Eski 93 Sokak) No:10 Çankaya – Ankara – TÜRKİYE

Tel: +90 312 443 03 90 (pbx) Faks: +90 312 443 03 76

E-posta: info@udemtd.com.tr Web: www.udem.com.tr

clarks

SERTİFİKALAR

CERTIFICATES



CERTIFICATE

61236

This certificate was given to the below stated company by UDEM International Certification
Audit Training Cent. Ind. Inc. Co.

Ender PVC ve Alüminyum Yapı Elemanları Sanayi ve Ticaret Anonim Şirketi

Head Office: 2.Organize Sanayi Bölgesi 27120 Tedaş Bitişiği Başpınar
GAZIANTEP / TURKEY

Factory: 4. Organize Sanayi Bölgesi 83422 No'lu Cadde Şehitkamil
GAZIANTEP / TURKEY

ISO 14001:2015

Scope: Manufacturing of aluminum profile

EA Code: 17

Certification Audit Date	: 09.05.2015
Decision Date	: 13.05.2015
Reissue Date	: 10.05.2018
Expiry Date	: 12.05.2019



UDEM International Certification
Audit Training Cent. Ind. Inc. Co.

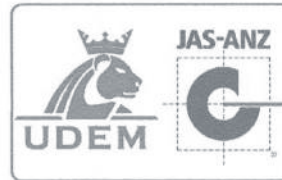

Hereby, UDEM International Certification Audit Training Cent. Ind. Inc. Co. certifies that the above stated company have the appropriate management system according to the requirements of the above standard. This certificate is valid for 3 years since the decision date as long as the system is effectively maintained and surveillance audits are carried out. The validity of the certificate can be checked through www.udem.com.tr, www.jas-anz.org/register. The certificate is the property of UDEM International Certification Audit Training Cent. Ind. Inc. Co. and shall be returned if requested.

Address: Mutlukent Mahallesi 2073 Sokak (Eski 93 Sokak) No:10 Çankaya – Ankara - TURKEY

Tel: +90 312 443 03 90 (pbx) Fax: +90 312 443 03 76

E-mail: info@udemltd.com.tr Web: www.udem.com.tr

clarks

SERTİFİKALAR

CERTIFICATES



SERTİFİKA

57689

Bu sertifika aşağıda adı geçen kuruluşa UDEM Uluslararası Belgelendirme Denetim Eğitim Merkezi San. ve Tic. A.Ş. tarafından verilmiştir.

Ender PVC ve Alüminyum Yapı Elemanları Sanayi ve Ticaret Anonim Şirketi

Merkez: 2.Organize Sanayi Bölgesi 27120 Tedaş Bitişiği Başpınar
GAZİANTEP / TÜRKİYE
Fabrika: 4. Organize Sanayi Bölgesi 83422 No'lu Cadde Şehitkamil
GAZİANTEP / TÜRKİYE

ISO 9001:2015

Kapsam: Alüminyum profil imalatı

EA Kodu: 17

Belgelendirme Denetim Tarihi : 09.05.2015
Tescil Tarihi : 13.05.2015
Yeniden Basım Tarihi : 10.05.2018
Geçerlilik Tarihi : 12.05.2019



UDEM Uluslararası Belgelendirme
Denetim Eğitim Merkezi
San. ve Tic. A.Ş. Onayı



UDEM Uluslararası Belgelendirme Denetim Eğitim Merkezi Sanayi ve Ticaret Anonim Şirketi bu belge ile adı geçen kuruluşun yukarıdaki standardın şartlarına uygun bir yönetim sistemine sahip olduğunu belgeler. Sistem etkin bir şekilde sürdürüldükçe ve gözetim denetimleri zamanında yapıldığı müddetçe bu belge tescil tarihinden itibaren 3 yıl boyunca geçerlidir. Belgenin geçerliliği www.udem.com.tr, www.jas-anz.org/register, İnternet sayfasından kontrol edilebilir. Bu belgenin mülkiyet hakkı UDEM Uluslararası Belgelendirme Denetim Eğitim Merkezi Sanayi ve Ticaret Anonim Şirketi'ne aittir ve istenildiğinde iade edilmelidir.

Adres: Mutlukent Mahallesi 2073 Sokak (Eski 93 Sokak) No:10 Çankaya – Ankara – TÜRKİYE

Tel: +90 312 443 03 90 (pbx) Faks: +90 312 443 03 76

E-posta: info@udemltd.com.tr Web: www.udem.com.tr

clarks

SERTİFİKALAR

CERTIFICATES



CERTIFICATE

57689

This certificate was given to the below stated company by UDEM International Certification
Audit Training Cent. Ind. Inc. Co.

Ender PVC ve Alüminyum Yapı Elemanları Sanayi ve Ticaret Anonim Şirketi

Head Office: 2.Organize Sanayi Bölgesi 27120 Tedaş Bitişiği Başpınar
GAZIANTEP / TURKEY

Factory: 4. Organize Sanayi Bölgesi 83422 No'lu Cadde Şehitkamil
GAZIANTEP / TURKEY

ISO 9001:2015

Scope: Manufacturing of aluminum profile

EA Code: 17

Certification Audit Date	: 09.05.2015
Decision Date	: 13.05.2015
Reissue Date	: 10.05.2018
Expiry Date	: 12.05.2019



UDEM International Certification
Audit Training Cent. Ind. Inc. Co.



Hereby, UDEM International Certification Audit Training Cent. Ind. Inc. Co. certifies that the above stated company have the appropriate management system according to the requirements of the above standard. This certificate is valid for 3 years since the decision date as long as the system is effectively maintained and surveillance audits are carried out. The validity of the certificate can be checked through www.udem.com.tr www.jas-anz.org/register. The certificate is the property of UDEM International Certification Audit Training Cent. Ind. Inc. Co. and shall be returned if requested.

Address: Mutlukent Mahallesi 2073 Sokak (Eski 93 Sokak) No:10 Çankaya – Ankara - TURKEY

Tel: +90 312 443 03 90 (pbx) Fax: +90 312 443 03 76

E-mail: info@udemitd.com.tr Web: www.udem.com.tr

clarks

SERTİFİKALAR

CERTIFICATES



S E R T İ F İ K A

UDEM Uluslararası Belgelendirme Denetim Eğitim Merkezi San. ve Tic. Ltd. Şti.
Mutlukent Mahallesi 2073 Sokak (Eski 93 Sokak) No:10 Çankaya – Ankara – TÜRKİYE

FABRİKA ÜRETİM KONTROLÜ UYGUNLUK BELGESİ 2292-CPR-4510

Avrupa Parlamentosu ve Konseyi'nin 9 Mart 2011 tarih ve 305/2011/EU sayılı Tüzüğü
(Yapı Malzemeleri Tüzüğü veya CPR) uyarınca, bu belge aşağıda belirtilen yapı malzemesine uygulanır.

YAPI MALZEMELERİ

Sertifika kapsamı : EN AW 6060, EN AW 6063 Alaşımından İmal Edilmiş Alüminyum Profil

- Ekstruze Edilmiş Boru
- Ekstruze Edilmiş Profil

Ender PVC ve Alüminyum Yapı Elemanları Sanayi ve Ticaret A.Ş.

2.Organize Sanayi Bölgesi 27120 Tedaş Bilişim Başpınar GAZİANTEP / TÜRKİYE

adı veya tescilli markası altında piyasaya sunulan

Ender PVC ve Alüminyum Yapı Elemanları Sanayi ve Ticaret A.Ş.

4. Organize Sanayi Bölgesi 83422 No'lu Cadde Şehitkamil GAZİANTEP / TÜRKİYE

ve imalat tesis(ler)inde üretilmiş

Bu Belge,

EN 15088:2006

standartının ZA Eki'nde tanımlanan performansın değişmezliğinin değerlendirilmesi ve doğrulanması ile ilgili tüm hükümlerin, sistem 2+ altında uygulandığını ve

fabrika üretim kontrolünün ilgili gereklerle uyum içerisinde olduğunu değerlendirildiğini göstermektedir.

(Signature)
UDEM Uluslararası Belgelendirme
Denetim Eğitim Merkezi
San. ve Tic. Ltd. Şti.
A.YÜCEL KERİMOĞLU
GENEL MÜDÜR

Bu belge, ilk olarak 13.05.2015 tarihinde düzenlenmiş, uyumlaştırılmış standart, yapı malzemesi, PDDD yöntemleri ya da üretim tesisindeki imalat koşulları önemli ölçüde değiştirilmediği sürece, onaylanmış fabrika üretim kontrolü UDEM tarafından askıya alınmaz veya iptal edilmez ise geçerlidir.



Adres: Mutlukent Mahallesi 2073 Sokak (Eski 93 Sokak) No:10 Çankaya – Ankara – TÜRKİYE

Tel: +90 312 443 03 90 Faks: +90 312 443 03 76

E-posta: info@udemltd.com.tr www.udemltd.com.tr

clarks

SERTİFİKALAR

CERTIFICATES



C E R T I F I C A T E

UDEM Uluslararası Belgelendirme Denetim Eğitim Merkezi San. ve Tic. Ltd. Şti.
Mutlukent Mahallesi 2073 Sokak (Eski 93 Sokak) No:10 Çankaya – Ankara – TÜRKİYE

Certificate of Conformity of the Factory Production Control 2292-CPR-4510

In compliance with Regulation (EU) No 305/2011 of the European Parliament and of the Council of 9 March 2011
(the Construction products Regulation or CPR), this certificate applies to the construction products

CONSTRUCTION PRODUCTS

Scope of certificate : EN AW 6060, EN AW 6063 Alloy Produced Aluminum Profile

- Extrudate Pipe
- Extrudate Profil

Placed on the market under the name or trade mark of

Ender PVC ve Alüminyum Yapı Elemanları Sanayi ve Ticaret A.Ş.

2. Organize Sanayi Bölgesi 27120 Tedaş Bittiği Başpınar GAZİANTEP / TURKEY

and produced in the manufacturing plant

Ender PVC ve Alüminyum Yapı Elemanları Sanayi ve Ticaret A.Ş.

4. Organize Sanayi Bölgesi 83422 No'lu Cadde Şehitkamil GAZİANTEP / TURKEY

This certificate attests that all provisions concerning the assessment and verification of constancy of
performance described in Annex ZA of the standards

EN 15088:2006

under system 2+ are applied and that

**the factory production control is assessed to be in conformity
with the applicable requirements**

UDEM International Certification
Auditing Training Centre Industry
and Trade Co. Ltd.
A. YÜCEL KERİMOĞLU
General Manager

This certificate was first issued on 13.05.2015 and will remain valid as long
as neither the harmonised standard, the construction product, the AVCP
methods nor the manufacturing conditions in the plant are modified
significantly, unless suspended or withdrawn by UDEM.

Address: Mutlukent Mahallesi 2073 Sokak (Eski 93 Sokak) No:10 Çankaya – Ankara – TURKEY

Phone: +90 0312 443 03 90 Fax: +90 0312 443 03 76

E-mail: info@udemltd.com.tr www.udemltd.com.tr





SERTİFİKALAR

CERTIFICATES



T.C.
TÜRK PATENT ENSTİTÜSÜ

MARKA TESCİL BELGESİ

Marka No : 2012 50009 - Ticaret

ENDER Alüminyum

Marka Sahibi :ENDERPEN PVC YAPI ELEMANLARI SAN. VE
TİC. A.Ş.
TÜRKİYE CUMHURİYETİ
2.ORGANİZE SANAYİ TEAŞ BİTİŞİĞİ NO:72
BAŞPINAR GAZİANTEP

Emtiası : 06
İlişiktir.

Markaların Korunması Hakkında 556 Sayılı Kanun Hükmünde
Kararnameye göre 31/05/2012 tarihinden itibaren ON YIL müddetle
01/08/2013 tarihinde tescil edilmiştir.

Elif B. AKIN
Enstitü Başkanı a.
Markalar Dairesi Başkanı

TÜRK PATENT [●] ENSTİTÜSÜ



NOTLAR / NOTES

Dotted lines for writing notes.

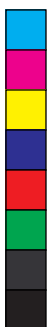



NOTLAR / NOTES

Lined writing area with a vertical scale on the left side ranging from 0 to 25.





NOTLAR / NOTES

A large area of horizontal dashed lines for writing notes.

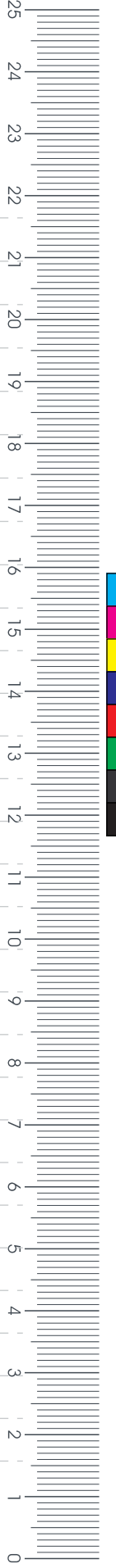



NOTLAR / NOTES

Detailed description of the ruled area: A large section of the page is ruled with horizontal dashed lines. On the left side of this section, there is a vertical ruler with markings from 0 to 25. To the left of the ruler is a color calibration strip with 12 colored squares labeled C, M, Y, CM, MY, CY, CMY, and K. To the right of the ruled area is another identical color calibration strip. The page is also marked with registration marks (crosshairs) at the corners and a grayscale calibration strip at the bottom center.



NOTLAR / NOTES

Dotted writing area for notes

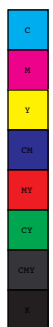
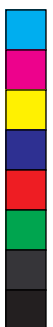



NOTLAR / NOTES

A large area of the page is filled with horizontal dashed lines, serving as a template for notes. A vertical ruler on the left side of this area is numbered from 0 to 25.





NOTLAR / NOTES

Large area with horizontal dashed lines for notes.





NOTLAR / NOTES

A large area with horizontal dashed lines for writing notes, spanning from approximately line 1 to line 25.





NOTLAR / NOTES

A large area of horizontal dashed lines for writing notes, spanning most of the page width.





NOTLAR / NOTES

A vertical ruler on the left side of the page is numbered from 0 to 25 in increments of 1. The page contains a series of horizontal dashed lines for writing notes, extending from the 22 cm mark down to the 0 cm mark.

